



Planning Division
Development Permit Application

Final action on development application or zone change is required within 120 days in accordance with provisions of ORS 227.175

A pre application conference is normally required prior to submittal of an application. Please visit the City's website for submittal requirements

Pre-Application Meeting Date: July 1, 2021

Incomplete applications will not be scheduled for public hearing until all of the required materials are submitted.

29799 SW Town Center Loop E, Wilsonville, OR 97070
Phone: 503.682.4960 Fax: 503.682.7025
Web: www.ci.wilsonville.or.us

Applicant:

Name: Dan Grimberg
Company: West Hills Land Development
Mailing Address: 3330 NW Yeon St, Ste 200
City, State, Zip: Portland, OR 97210
Phone: 503.789.0358 Fax:
E-mail: dan@westhillsdevelopment.com

Authorized Representative:

Name: Li Alligood, AICP
Company: Otak, Inc.
Mailing Address: 808 SW Third Ave, Ste 800
City, State, Zip: Portland, OR 97204
Phone: 503.415.2384 Fax:
E-mail: li.alligood@otak.com

Property Owner:

Name: Sheri Miller & Jamie Mehus
Company: NA
Mailing Address: 6725 SW Frog Pond Ln
City, State, Zip: Wilsonville, OR 97070
Phone: Fax:
E-mail:

Property Owner's Signature:

Signature: Sheri Miller
Printed Name: Sheri Miller Date: 10-7-21

Applicant's Signature: (if different from Property Owner)

Signature: Dan Grimberg
Printed Name: Dan Grimberg Date: 10/7/21

Site Location and Description:

Project Address if Available: 6725 SW Frog Pond Ln Suite/Unit
Project Location:
Tax Map #(s): 31 W 12D Tax Lot #(s): 401 and 402 County: Washington Clackamas

Request:

Residential subdivision (Frog Pond Oaks) of 41 lots, two tracts, and associated infrastructure in Frog Pond West.

Project Type: Class I Class II Class III

Residential Commercial Industrial Other:

Application Type(s):

- Annexation Appeal Comp Plan Map Amend Parks Plan Review
Final Plat Major Partition Minor Partition Request to Modify Conditions
Plan Amendment Planned Development Preliminary Plat Site Design Review
Request for Special Meeting Request for Time Extension Signs Stage II Final Plan
SROZ/SRIR Review Staff Interpretation Stage I Master Plan Variance
Type C Tree Removal Plan Tree Permit (B or C) Temporary Use
Villebois SAP Villebois PDP Villebois FDP Other (describe)
Zone Map Amendment Waiver(s) Conditional Use

Frog Pond Oaks Subdivision (Miller Property)
**Land Use Request for Annexation; Zoning Map
Amendment; Stage I Master Plan; Stage II Final
Plan; Site Development Review of Parks & Open
Space; Tentative Subdivision Plat; Type C Tree
Plan; and Waivers**
Land Use Incompleteness Response Submittal

Submitted for:

City of Wilsonville
29799 SW Town Center Loop E.
Wilsonville, OR 97070

February 17, 2022

Prepared By:

Otak, Inc.
808 SW Third Avenue, Suite 800
Portland, OR 97204

Project No. 20141.000

REQUESTS

Annexation, Zoning Map Amendment, Planned Development – Stage I Preliminary Plan, Planned Development – Stage II Final Plan, Site Development Review, Type C Tree Plan, Preliminary Subdivision Plat, and two waivers are requested for the 10.46-acre site consisting of two tax lots. The site is located within the West Neighborhood of the Frog Pond Area Plan boundaries and is subject to Planned Development (PD) review. The site is in rural residential and agricultural use and is located at 6725 SW Frog Pond Lane. The site is comprised of two tax lots of roughly equal size. There is one existing single-family home located on the site, with multiple outbuildings and accessory structures. See Sheets P1.00 and P1.10.

SITE INFORMATION

SUBJECT SITE: TLIDs 31W12D 401 and 31W12D 402

SITE AREA: 10.46 acres

COMPREHENSIVE PLAN DESIGNATION: *Current: Clackamas County RFFF5*
Proposed: Residential Neighborhood RN

ZONING DESIGNATION: *Current: Clackamas County RFFF5*
Proposed: Residential Neighborhood RN

APPLICANT/PROPERTY OWNER

APPLICANT: West Hills Land Development LLC
3330 NW Yeon Ave, Suite 200
Portland, OR 97210

Contact: Dan Grimberg
503.726.7033
dan@westhillsdevelopment.com

OWNER: 31W12D 00402 & 31W12D 00401
Sheri Miller and James Mehus
6725 SW Frog Pond Lane
Portland, OR 97210

PROJECT DEVELOPMENT TEAM

APPLICANT'S REPRESENTATIVE/
LAND USE PLANNER: Otak, Inc.
808 SW Third Avenue, Suite 800
Portland, OR 97204

Contact: Li Alligood, AICP
503.415.2384
li.alligood@otak.com

CIVIL ENGINEER: Contact: Mike Peebles, PE
503.415.2354
mike.peebles@otak.com

LANDSCAPE ARCHITECT: Contact: Gabriel Kruse, PLA
503.415.2402
gabriel.kruse@otak.com

SURVEYOR: Contact: Mike Spelts, PLS

503.415.2321
mike.spelts@otak.com

**GEOTECHNICAL
ENGINEER:**

Hardman Geotechnical Services, Inc.
10110 SW Nimbus Ave, Suite B-5
Portland, OR 97223

Contact: Scott Hardman
503.530.8076
shardman.hgsi@frontier.com

ARBORIST:

Portland Tree Consulting
PO Box 19042
Portland, OR 97280

Contact: Peter Torres, MF
503.452.8160
peter@pdxtreeconsulting.com

**NATURAL RESOURCES
CONSULTANT:**

AKS Engineering & Forestry, LLC
12965 SW Herman Rd, Suite 100
Tualatin, OR 97062

Contact: Stacey Reed, PWS
503.563.6151
StaceyR@aks-eng.com

TABLE OF CONTENTS

	Page
I. Requests	1
II. Project Description	1
III. Comprehensive Plan Policies	2
A. Urban Growth Management.....	2
B. Land Use and Development.....	4
C. Areas of Special Interest.....	6
IV. Zoning Regulations	7
A. Section 4.035 Site Development Permits.....	7
B. Section 4.113. Standards Applying to Residential Developments In Any Zone.....	8
C. Section 4.118 Standards Applying in all Planned Development Zones.....	10
D. Section 4.124. Standards applying to all Planned Development Residential Zones.....	12
E. Section 4.127. Residential Neighborhood (RN) Zone.....	14
F. Section 4.139. Significant Resource Overlay Zone (SROZ) Ordinance.....	27
G. Section 4.140. Planned Development Regulations.....	29
V. General Development Regulations	34
A. Section 4.154. On-site Pedestrian Access and Circulation.....	34
B. Section 4.155. General Regulations - Parking, Loading and Bicycle Parking.....	35
C. Section 4.156. Sign Code Regulations.....	37
D. Section 4.167. General Regulations - Access, Ingress and Egress.....	37
E. Section 4.169. General Regulations – Double-Frontage Lots.....	37
F. Section 4.171. General Regulations - Protection of Natural Features and Other Resources.....	38
G. Section 4.175. Public Safety and Crime Prevention.....	40
H. Section 4.176. Landscaping, Screening, and Buffering.....	40
I. Section 4.177. Street Improvement Standards.....	49
J. Section 4.180. Exceptions and Modifications - Projections into Required Yards.....	53
K. Section 4.181. Exceptions & Modifications - Height Limits.....	53
L. Section 4.182. Exceptions and Modifications - Setback Modifications.....	53
M. Section 4.197. Zone Changes and Amendments To This Code – Procedures.....	54
VI. Land Divisions	55
A. Section 4.210. Application Procedure.....	55
B. Section 4.236. General Requirements - Streets.....	57
C. Section 4.237. General Requirements – Other.....	59
D. Section 4.262. Improvements - Requirements.....	61
VII. Underground Utilities	63
A. Section 4.300 General.....	63
B. Section 4.320. Requirements.....	63
VIII. Site Design Review	63
A. Section 4.400. Purpose.....	63
B. Section 4.421. Criteria and Application of Design Standards.....	64
C. Section 4.440. Procedure.....	66
IX. Tree Preservation and Protection	67
A. Section 4.600.20. Applicability of Subchapter.....	67
B. Section 4.610.00. Application Review Procedure.....	69
C. Section 4.620.00. Tree Relocation, Mitigation, Or Replacement.....	73
X. Annexations and Urban Growth Boundary Amendments	74
A. Section 4.700. Procedures Relating To The Processing Of Requests For Annexation And Urban Growth Boundary Amendments.....	74
XI. Conclusion	75

Appendices

- Appendix A — Annexation Petitions and Certifications
- Appendix B — Stormwater Preliminary Drainage Report dated January, 2022, by Otak, Inc.
- Appendix C — Traffic Impact Analysis dated November 2021, by DKS and Associates
- Appendix D — Map Verification/Wetland Delineation Report: October 2021, by AKS Engineering & Forestry
- Appendix E — Arborist Report dated January 7, 2022, by Portland Tree Consulting
- Appendix F — Updated Geotechnical Reports by Hardman Geotechnical Services, Inc.
- Appendix G — Stafford Meadows PUD recorded CC&Rs and Bylaws
- Appendix H — Example Building Elevations
- Appendix I — Service Provider Letter from Republic Services
- Appendix J — Service Provider Letter from Tualatin Valley Fire and Rescue October 25, 2021
- Appendix K — BPA Communication for Easement

Reduced Size Plan Set

- Sheet P0.00 – Cover Sheet
- Sheet P1.00 – Existing Conditions – Aerial Photo
- Sheet P1.10 – Existing Conditions – Survey Mapping
- Sheet P2.00 – Preliminary Site Plan
- Sheet P2.10 – Preliminary Street Cross Sections
- Sheet P3.00 – Preliminary Plat
- Sheet P4.00 – Preliminary Utility Plan
- Sheet P5.00 – Preliminary Grading Plan
- Sheet P6.00 – Annexation Plan
- Sheet P7.00 – Zoning Map
- Sheet P8.00 – Proposed Circulation and Connectivity
- Sheet P9.00 – Subdistricts and Density
- Sheet L1.00 – Tree Removal and Protection Plan
- Sheet L1.10 – Existing Tree Tables
- Sheet L2.00 – Overall Landscape Plan
- Sheet L2.10 – Tracts D and E Landscape Plans
- Sheet L2.20 – Tracts A and B Landscape Plans
- Sheet L2.30 – LIDA Planter Landscape Plans
- Sheet L2.40 – Landscape Notes and Details
- Sheet IL-1 – Illumination Notes
- Sheet IL-2 – Illumination Details
- Sheet IL-3 – Illumination Details Continued
- Sheet IL-4 – Illumination Plan

Note: All plan sheets are also separately bound in a larger format within the development application submittal.

Tables

Table 1. Proposed residential lots	5
Table 2. Frog Pond Oaks Density Calculations.....	5
Table 3. Compliance with Frog Pond West Neighborhood Lot Standards.....	19
Table 4. Required open space	20
Table 5. Tree Credits.....	46

I. Requests

Annexation, Zoning Map Amendment, Planned Development – Stage I Preliminary Plan, Planned Development – Stage II Final Plan, Site Development Review, Type C Tree Plan, Preliminary Subdivision, and Waiver approvals are requested for the 10.46-acre site consisting of two tax lots abutting SW Frog Pond Lane. The site is located within the West Neighborhood of the Frog Pond Area Plan boundaries and is subject to Planned Development (PD) review. The proposed development consists of an annexation and zone map amendment, a 41-lot subdivision, and infrastructure improvements for the Frog Pond Oaks (Miller) property.

The site is in rural residential and agricultural use. The eastern tax lot contains one existing single-family home and multiple outbuildings and accessory structures. See Sheets P1.00 and P1.10.

Annexation approval is required to annex the Miller property into City limits and connect to City utilities.

Zoning Map Amendment approval is required to apply the RN zoning to the Miller property. The property is currently zoned Clackamas County RRFF 5.

Stage I Master Plan and Stage II Final Plan approvals are required because all development of 2 acres or greater in the RN Zone requires approval as a Planned Development, which requires approval of Stage I and Stage II applications. As shown on Sheet P0.00, the Frog Pond Oaks development is 10.46 acres in area, which exceeds the 2-acre threshold.

Site Design Review approval is required for review of tracts and their landscaping, and landscaping in the public right-of-way.

Tentative Subdivision Plat approval is required to divide the property into 41 lots and five tracts. Land divisions of four lots or more are defined as subdivisions.

Type C Tree Plan approval is required to remove trees on site for development.

II. Project Description

The subject site is located within the Frog Pond West Master Plan area of the City of Wilsonville. It is the applicant's fifth development in Frog Pond West (previous developments are Frog Pond Estates, to the southwest; Stafford Meadows, to the south; Frog Pond Meadows, to the south; and Frog Pond Ridge, to the southeast).

The applicant, West Hills Land Development LLC, proposes to divide the subject site into 41 lots and 5 tracts and develop the public infrastructure required to serve those lots. The 10.46-acre site consists of two tax lots located in unincorporated Clackamas County, within the City of Wilsonville Urban Growth Boundary (UGB) and the Frog Pond West subarea of the city. The site is currently zoned Clackamas County Rural Residential Farm Forest 5-Acre (RRFF5). This application will annex the site to the City of Wilsonville and apply the Residential Neighborhood RN zone to the site.

The site is currently in residential and agricultural use and is adjacent to the City of Wilsonville RN zone to the south, across SW Frog Pond Lane. To the west and east are properties zoned Clackamas County RRFF5, and to the north, outside of the City of Wilsonville UGB, is property zoned Clackamas County EFU.

There are no mapped SROZ on the site, but there is a small, contained wetland located near the middle of the site on both tax lots. The proposed development would remove this wetland.

Per Figure 6 of the Frog Pond West Master Plan, the project site is located within the Frog Pond West Subdistricts 11-R7 and 10-R5.

III. Comprehensive Plan Policies

A. Urban Growth Management

Response: Annexation of the site is subject to the provisions of the Urban Growth Management chapter of the Comprehensive Plan, specifically Goal 2.1 and Policy 2.2.1.

Policy 2.2.1

The City of Wilsonville shall plan for the eventual urbanization of land within the local planning area, beginning with land within the Urban Growth Boundary.

Implementation Measure 2.2.1.a

Allow annexation when it is consistent with future planned public services and when a need is clearly demonstrated for immediate urban growth.

Response: The Comprehensive Plan states:

“Based on Metro’s (1981) regional growth allocation statistics, Wilsonville’s population was projected to grow to 15,600 by the year 2000. In the same time period, the City’s economic growth is expected to generate a total of 14,400 jobs. Those projections proved to be surprisingly accurate. In fact, Wilsonville’s population in 2000 approached the 15,600 figure, and the number of jobs exceeded the 14,400 figure.”

The subject site is located within the West Neighborhood of the Frog Pond planning area. The Frog Pond Area Plan was adopted in 2015 and the Frog Pond West Master Plan was adopted in 2017 and provides for single-family residential uses to meet the needs of Wilsonville’s growing population. The Frog Pond Area Plan includes a transportation framework, parks and open space framework, and infrastructure framework to support development within the Frog Pond area and assure adequate public services. This criterion is met.

Implementation Measure 2.2.1.e

Changes in the City boundary will require adherence to the annexation procedures prescribed by State law and Metro standards. Amendments to the City limits shall be based on consideration of:

1. *Orderly, economic provision of public facilities and services, i.e., primary urban services are available and adequate to serve additional development or improvements are scheduled through the City’s approved Capital Improvements Plan.*

Response: The Frog Pond Area Plan includes implementation measures to ensure the orderly and economic provision of public facilities and services for the Frog Pond Area, including Frog Pond West. Site development is proposed with concurrent applications for Stage I and Stage II Master Plans and Preliminary Subdivision, which proposes the extension of public facilities and services to the Frog Pond Oaks site. These proposed services are generally consistent with the Frog Pond Area Plan and Frog Pond West Master Plan, and the City’s Finance Plan and Capital Improvements Plan. This criterion is met.

2. *Availability of sufficient land for the various uses to insure choices in the marketplace for a 3 to 5 year period.*

Response: The inclusion of the Frog Pond area within the UGB and the adoption of the Frog Pond Area Plan demonstrate the need for residential development in the Frog Pond Area. Annexation of the subject site will allow development of the uses envisioned by the adopted Frog Pond West Master Plan.

3. *Statewide Planning Goals.*

Response: The Statewide Planning Goals provide direction to local jurisdictions regarding the State’s policies on land use. These goals are implemented at the local level through Comprehensive Plans, which are required and reviewed by the Department of Land Conservation and Development (DLCD) for conformance with the Statewide Planning Goals. It is assumed that the City’s adopted Comprehensive Plan (which includes the adopted Frog Pond Area Plan and Frog Pond West Master Plan) is in

compliance with Statewide Planning Goals (specifically Goal 2: Land Use Planning), and that compliance with the Wilsonville Comprehensive Plan also demonstrates compliance with the Statewide Planning Goals.

Relevant Statewide Planning Goals include:

- Goal 10: Housing
- Goal 12: Transportation
- Goal 14: Urbanization

Responses to each are addressed below.

Goal 10: Housing

This goal identifies a need for “needed housing,” which is defined (for cities having populations larger than 2,500) as attached and detached single-family housing, multiple-family housing, and manufactured homes. Annexation of the subject site into the Wilsonville city limits will provide attached and detached single-family housing, which is defined as “needed housing” and will serve an identified need in the city.

Goal 12: Transportation

This goal identifies the importance of a safe, convenient, and economic transportation system, and requires local jurisdictions to adopt a Transportation System Plan (TSP). The proposed annexation area will comply with the Wilsonville Transportation System Plan, which has been updated to include the Frog Pond West area. Annexation of the subject site will allow for development of the site, including new street connections included in the TSP.

Goal 14: Urbanization

This goal identifies the need for orderly and efficient growth, the need to accommodate housing and employment within the urban growth boundary, and the importance of livable communities. The orderly annexation of this site, which is located within the Frog Pond West area, will provide additional housing within the UGB.

4. Applicable Metro Plans;

Response: The Metro Code contains applicable requirements. Section 3.07 Urban Growth Management Functional Plan (Functional Plan) provides direction to communities within Metro’s jurisdiction regarding the region’s land use and transportation policies, and Chapter 3.09 Local Government Boundary Changes identifies requirements for annexations.

Wilsonville is located within the jurisdiction of Metro, and its local plans and land use ordinances are subject to review by Metro. It is assumed that the City’s adopted Comprehensive Plan (which includes the adopted Frog Pond West Master Plan) is in compliance with the Functional Plan, and that compliance with the Wilsonville Comprehensive Plan also demonstrates compliance with the Functional Plan.

Metro Code 3.07 Urban Growth Management Functional Plan

Applicable Titles of the Functional Plan are addressed below.

Title 1: Housing Capacity

Annexation of the subject site will increase the housing capacity of the city, as described and confirmed through adoption of the Frog Pond West Master Plan.

Title 11: Planning for New Urban Areas

The City of Wilsonville’s adopted Frog Pond Area Plan and Frog Pond West Master Plan include a comprehensive overview of future development in the Frog Pond planning area. The proposed annexation will expand the boundaries of the city and allow for orderly development of the Frog Pond West Area.

Metro Code 3.09 Local Government Boundary Changes

3.09.040 Requirements for Petitions

A. A petition for a boundary change must contain the following information:

1. The jurisdiction of the reviewing entity to act on the petition;

2. *A map and a legal description of the affected territory in the form prescribed by the reviewing entity;*
 3. *For minor boundary changes, the names and mailing addresses of all persons owning property and all electors within the affected territory as shown in the records of the tax assessor and county clerk; and*
 4. *For boundary changes under ORS 198.855(3), 198.857, 222.125 or 222.170, statements of consent to the annexation signed by the requisite number of owners or electors.*
- B. *A city, county and Metro may charge a fee to recover its reasonable costs to carry out its duties and responsibilities under this chapter.*

Response: The petition included as Appendix A includes the information required by this section.

5. *Encouragement of development within the City limits before conversion of urbanizable (UGB) areas.*

Response: The subject site is located within the Frog Pond West planning area, which has been the subject of a great deal of local planning efforts. Expansion of the city's UGB to include this area was completed due to a determination that there was inadequate development area within the existing city limits. Annexation of this site will allow development that implements the vision of the Frog Pond West Master Plan.

B. *Land Use and Development*

Response: The requested zone change to RN is subject to compliance with Comprehensive Plan map designation and applicable goals, policies and objectives as well as compliance with the Land Use and Development chapter of the Comprehensive Plan, specifically Policy 4.1.4 and implementation measures 4.1.4.b, d, e, q, and x.

Policy 4.1.4

The City of Wilsonville shall provide opportunities for a wide range of housing types, sizes, and densities at prices and rent levels to accommodate people who are employed in Wilsonville.

Implementation Measure 4.1.4.b

Plan for and permit a variety of housing types consistent with the objectives and policies set forth under this section of the Comprehensive Plan, while maintaining a reasonable balance between the economics of building and the cost of supplying public services. It is the City's desire to provide a variety of housing types needed to meet a wide range of personal preferences and income levels. The City also recognizes the fact that adequate public facilities and services must be available in order to build and maintain a decent, safe, and healthful living environment.

Response: The proposed zone change to Residential Neighborhood RN implements the adopted Frog Pond West Master Plan and allows for development of single-family detached housing. The proposed development permitted by the zone change will provide adequate public facilities and services to serve the new dwellings.

Implementation Measure 4.1.4.d

Encourage the construction and development of diverse housing types, but maintain a general balance according to housing type and geographic distribution, both presently and in the future. Such housing types may include, but shall not be limited to: Apartments, single-family detached, single-family common wall, manufactured homes, mobile homes, modular homes, and condominiums in various structural forms.

Response: The Frog Pond West Master Plan anticipates single-family detached and attached development. The proposed zone change, with the recently adopted middle housing ordinance, implements the adopted Frog Pond West Master Plan and allows for development of single-family detached and attached housing.

Implementation Measure 4.1.4.e

Targets are to be set in order to meet the City's Goals for housing and assure compliance with State and regional standards.

Response: The Frog Pond Area Plan and Frog Pond West Master Plan, as amended by the recently adopted middle housing ordinance, establish minimum and maximum residential densities for this area in compliance with state and regional standards. The proposed zone change will allow development of the subject site in conformance with those densities.

Implementation Measure 4.1.4.q

The City will continue to allow for mobile homes and manufactured dwellings, subject to development review processes that are similar to those used for other forms of housing. Individual units will continue to be allowed on individual lots, subject to design standards. Mobile home parks and subdivisions shall be subject to the same procedures as other forms of planned developments.

Response: No mobile homes or manufactured dwellings are proposed, but the applicant acknowledges that they are allowed.

Implementation Measure 4.1.4.x

Apartments and mobile homes are to be located to produce an optimum living environment for the occupants and surrounding residential areas. Development criteria includes:

1. *Buffering by means of landscaping, fencing, and distance from conflicting uses.*
2. *Compatibility of design, recognizing the architectural differences between apartment buildings and houses.*
3. *On-site recreation space as well as pedestrian and bicycle access to parks, schools, mass transit stops and convenience shopping.*
4. *The siting of buildings to minimize the visual effects of parking areas and to increase the availability of privacy and natural surveillance for security.*

Response: No apartments or mobile homes are proposed or permitted by the requested zoning.

RESIDENTIAL PLANNING DISTRICTS SHOWN ON THE LAND USE MAP OF THE COMPREHENSIVE PLAN

Response: The Frog Pond West Master Plan and the RN zone identify minimum density targets for the Frog Pond West subdistricts. As shown in Table 1 below, the proposed development will consist of 41 lots.

Table 1: Proposed residential units

Land Use Designation	Sub-district	Gross Site Area (ac)	% of Subdistrict	Minimum du	Maximum du	Proposed du	Comment
R-7	11	7.7	60.3	28	35	29	Meets density requirements
R-5	10	2.8	50.2	15	19	12	Does not meet density requirements. A waiver has been requested.
Total		10.4		43	54	41	

Table 2: Frog Pond Oaks Density Calculations

Frog Pond Oaks Density Calculations										
Subdistrict	Net Subdistrict Area (sf)	Net Subdistrict Area (ac)	Proposed Site area (sf)	Proposed Site area (ac)	Percentage of Subdistrict	Minimum Units Allowed in Subdistrict	Maximum Units Allowed in Subdistrict	Minimum Units Allowed on Site	Maximum Units Allowed on Site	Proposed Lots
10	239,637	5.50	120,353	2.76	50.22%	30	38	15	19	12
11	554,964	12.74	334,573	7.68	60.29%	46	58	28	35	29
			454,926	10.44						

The Frog Pond West Master Plan establishes that the Subdistrict 11/R7 zone shall have a minimum density of 46 dwelling units and a maximum density of 58 dwelling units applicable to the entirety of the subdistrict. The subject site's portion of the Subdistrict 11 is 60.3-percent, which requires a minimum density of 28 dwelling units, and a maximum density of 35 dwelling units. The proposed development within Subdistrict 11/R7 zone includes 29 dwelling units which meets the minimum and maximum densities established in the Frog Pond West Master Plan.

The Frog Pond West Master Plan establishes that the Subdistrict 10/R5 zone have a minimum density of 30 dwelling units and a maximum density of 38 dwelling units applicable to the entirety of the subdistrict. The subject site's portion of Subdistrict 10 is 50.2-percent, which requires a minimum density of 15 and a maximum density of 19 dwelling units.

This application includes 12 proposed dwelling units on detached lots in Subdistrict 10/R5 zone. A waiver per Section 4.118.3.B.2 is requested to the minimum density standards in Subdistrict 10/R5 zone. Due to the overall site's topography, there are two large stormwater tracts proposed to be located in Subdistrict 10 to manage stormwater from both Subdistricts 11 and 10. These densities are not specifically addressed in Comprehensive Plan policies.

Low impact development approach (LIDA) facilities are proposed on the extension of SW Windflower Street (Proposed Street C), Proposed Street D, SW Frog Pond Lane, and SW Willow Creek Drive. Adding additional LIDA facilities to the site will not mitigate the need for, or reduce the size of the two stormwater ponds proposed in Tracts A and B (see Appendix B for stormwater calculations).

Due to the street alignments and extensions required by the Frog Pond West Master Plan, the proposed lots in Subdistrict 10 are limited in configuration and location. Proposed Lots 1-6, bound by Street C, SW Frog Pond Lane, Willow Creek Drive, and SW Larkspur Terrace in the SW corner of the subdistrict, are all larger than minimum lot size requirements. An additional lot abutting Street C could meet the minimum 35-ft. width and 60-ft. depth requirement but could not meet the minimum 4,000 sq. ft. lot area standard. The total area of this block, minus Tract A is approximately 28,000 sq. ft. in size. Assessing area alone, there is space to create one additional lot, which would be seven lots. However, given the constraints of the required street system, and the site's logical placement of a stormwater management facility, only six lots are able to practically fit, while meeting minimum lot standards. As a result, the lots, as proposed, are larger than the minimum standard of Subdistrict 10, but are still smaller than those proposed in the medium lot sized Subdistrict 11/R7 portion of the site.

C. Areas of Special Interest

AREA L

This area is located north of Boeckman Road, south of Frog Pond Lane, west of Wilsonville (Stafford) Road, and east of Boeckman Creek. It contains a mixture of rural-residential and small agricultural uses. Eventual redevelopment of the area is expected to be primarily residential. The West Linn – Wilsonville School District and a church have acquired property in the area, causing speculation that redevelopment with full urban services could occur prior to 2010. In fact, construction of a new church has already commenced at the corner of Boeckman Road and Wilsonville/Stafford Road.

The existing development patterns, and values of the existing homes in the Frog Pond neighborhood are expected to slow the redevelopment process. Most of the landowners in the area have expressed little or no interest in urban density redevelopment. The Metro standard for urbanizing residential land is an average residential density of at least 10 units/acre. Those densities may not appeal to many of the current residents of the area who live in large homes on lots with acreage. In view of the School District's plans to construct a school within the neighborhood, the City must prepare plans to serve the new school and the surrounding area.

Response: The site is located within Area L, now known as the Frog Pond Plan Area. The Frog Pond West Master Plan was adopted in 2017 and provides land use and infrastructure plans for urban density redevelopment. The proposed zone change to RN implements the provisions of the Frog Pond West Master Plan.

IV. Zoning Regulations

A. Section 4.035 Site Development Permits

[...]

(.04) *Site Development Permit Application.*

A. *An application for a Site Development Permit shall consist of the materials specified as follows, plus any other materials required by this Code.*

1. *A completed Permit application form, including identification of the project coordinator, or professional design team.*

Response: Completed application forms have been submitted.

2. *An explanation of intent, stating the nature of the proposed development, reasons for the Permit request, pertinent background information, information required by the development standards and other information specified by the Director as required by other sections of this Code because of the type of development proposal or the area involved or that may have a bearing in determining the action to be taken. As noted in Section 4.014, the applicant bears the burden of proving that the application meets all requirements of this Code.*

Response: This narrative includes a description of the nature of the proposed development, reasons for the request, pertinent background information, and responses to applicable criteria.

3. *Proof that the property affected by the application is in the exclusive ownership of the applicant, or that the applicant has the consent of all individuals or partners in ownership of the affected property.*

Response: The submittal includes application forms signed by the property owners and the applicant, verifying that all owners consent to the application.

4. *Legal description of the property affected by the application.*

Response: A legal description of the property is included in Appendix A.

5. *The application shall include conceptual and quantitatively accurate representations of the entire development sufficient to judge the scope, size and impact of the development on the community, public facilities and adjacent properties; and except as otherwise specified in this Code, shall be accompanied by the following information,*

Response: The exhibits and reports included with this submittal provide this information.

6. *Unless specifically waived by the Director, the submittal shall include: ten (10) copies folded to 9" x 12" or (one (1) set of full-sized scaled drawings and nine (9) 8 1/2" x 11" reductions of larger drawings) of the proposed Site Development Plan, including a small scale vicinity map and showing:*

a. *Streets, private drives, driveways, sidewalks, pedestrian ways, off-street parking, loading areas, garbage and recycling storage areas, power lines and railroad tracks, and shall indicate the direction of traffic flow into and out of off-street parking and loading areas, the location of each parking space and each loading berth and areas of turning and maneuvering vehicles.*

b. *The Site Plan shall indicate how utility service, including sanitary sewer, water and storm drainage, are to be provided. The Site Plan shall also show the following off-site features: distances from the subject property to any structures on adjacent properties and the locations and uses of streets, private drives, or driveways on adjacent properties.*

c. *Location and dimensions of structures, utilization of structures, including activities and the number of living units.*

d. *Major existing landscaping features including trees to be saved, and existing and proposed contours.*

e. *Relevant operational data, drawings and/or elevations clearly establishing the scale, character and relationship of buildings, streets, private drives, and open space.*

- f. *Topographic information sufficient to determine direction and percentage of slopes, drainage patterns, and in environmentally sensitive areas, e.g., flood plain, forested areas, steep slopes or adjacent to stream banks, the elevations of all points used to determine contours shall be indicated and said points shall be given to true elevation above mean sea level as determined by the City Engineer. The base data shall be clearly indicated and shall be compatible to City datum if bench marks are not adjacent. The following intervals shall be shown:*
 - i. *One (1) foot contours for slopes of up to five percent (5%);*
 - ii. *Two (2) foot contours for slopes of from six percent (6%) to twelve percent (12%);*
 - iii. *Five (5) foot contours for slopes of from twelve percent (12%) to twenty percent (20%). These slopes shall be clearly identified, and*
 - iv. *Ten (10) foot contours for slopes exceeding twenty percent (20%).*
- g. *A tabulation of land area, in square feet, devoted to various uses such as building area (gross and net rentable), parking and paving coverage, landscaped area coverage and average residential density per net acre.*
- h. *An application fee as set by the City Council.*
- i. *If there are trees in the development area, an arborist's report, as required in Section 4.600. This report shall also show the impacts of grading on the trees.*
- j. *A list of all owners of property within 250 feet of the subject property, printed on label format. The list is to be based on the latest available information from the County Assessor.*

Response: A site circulation plan is included as Sheet P8.00; utility plans are included as Sheets P4.00 to P4.20; existing conditions plans, including contours and trees, are included as Sheets P1.0 and P1.10; operational data is included in Sheets P2.00, P3.00, L2.00, and P8.00; topographic information is shown on Sheet P1.0; a tabulation of land area and uses is included in Sheet P2.00; the application fee has been submitted with this application; an arborist report is included as Appendix E; and a list of property owners within 250 ft. of the subject property is included with this application.

B. Section 4.113. Standards Applying to Residential Developments In Any Zone

(.01) Outdoor Recreational Area in Residential Developments

(.02) Open Space Area shall be provided in the following manner

Response: The site is located within the Frog Pond West master plan area, and the provisions of Section 4.127 supersede these standards and are addressed below.

(.03) Building Setbacks

(for Fence Setbacks, see subsection .08). The following provisions apply unless otherwise provided for by the Code or a legislative master plan. [Section .03 Building Setbacks amended by Ord. 806, /17/2017]

A. *For lots over 10,000 square feet: [...]*

Response: No lots over 10,000 square feet are proposed. These standards are not applicable.

B. *For lots not exceeding 10,000 square feet:*

1. *Minimum front yard setback: Fifteen (15) feet, with open porches allowed to extend to within ten (10) feet of the property line.*
2. *Minimum side yard setback: One story: five (5) feet; Two or more stories: seven (7) feet. In the case of a corner lot, abutting more than one street or tract with a private drive, the side yard on the street side of such lot shall be not less than ten (10) feet.*
3. *In the case of a key lot, the front setback shall equal one-half (1/2) the sum of depth of the required yard on the adjacent corner lot along the street or tract with a private drive upon which the key lot faces and the setback required on the adjacent interior lot.*
4. *No structure shall be erected within the required setback for any future street shown within the City's adopted Transportation Master Plan or Transportation Systems Plan.*
5. *Minimum setback to garage door or carport entry: Twenty (20) feet. Wall above the garage door may project to within fifteen (15) feet of property line, provided that clearance to garage door is maintained. Where access is taken from an alley, garages or carports may*

be located no less than four (4) feet from the property line adjoining the alley.

6. *Minimum rear yard setback: One story: fifteen (15) feet. Two or more stories: Twenty (20) feet. Accessory buildings on corner lots must observe the same rear setbacks as the required side yard of the abutting lot. [Section 4.113(.03) amended by Ord. 682, 9/9/10]*

Response: The site is within the Frog Pond West Master Plan Area and the RN zone is being applied through this application. The site is subject to the setback requirements of Section 4.127, which are addressed in the responses to that section.

(.04) Height Guidelines

The Development Review Board may regulate heights as follows:

- A. *Restrict or regulate the height or building design consistent with adequate provision of fire protection and fire-fighting apparatus height limitations.*
- B. *To provide buffering of low density developments by requiring the placement of buildings more than two (2) stories in height away from the property lines abutting a low density zone.*
- C. *To regulate building height or design to protect scenic vistas of Mt. Hood or the Willamette River from greater encroachments than would occur if developed conventionally.*

Response: No low-density developments are adjacent to the site and no scenic vistas have been identified on the site. No height regulation is needed.

(.05) Residential uses for treatment or training

- A. *Residential Homes, as defined in Section 4.001, shall be permitted in any location where a single-family dwelling is permitted.*
- B. *Residential Facilities, as defined in Section 4.001, shall be permitted in any location where multiple-family dwelling units are permitted.*

Response: No residential homes or facilities are proposed. These standards are not applicable.

(.06) Off Street Parking

Off-street parking shall be provided as specified in Section 4.155.

Response: The provisions of Section 4.155 are addressed in Section V.B of this narrative.

(.07) Signs

Signs shall be governed by the provisions of Sections 4.156.01 – 4.156.11.

Response: The provisions of Sections 4.156.01-11 are addressed in Section V.C of this narrative.

(.08) Fences

- A. *The maximum height of a sight-obscuring fence located in the required front yard of a residential development shall not exceed four (4) feet.*
- B. *The maximum height of a sight-obscuring fence located in the side yard of a residential lot shall not exceed four (4) feet forward of the building line and shall not exceed six (6) feet in height in the rear yard, except as approved by the Development Review Board. Except, however, that a fence in the side yard of residential corner lot may be up to six (6) feet in height, unless a greater restriction is imposed by the Development Review Board acting on an application. A fence of up to six (6) feet in height may be constructed with no setback along the side, the rear, and in the front yard of a residential lot adjoining the rear of a corner lot as shown in the attached Figure.*
- C. *Notwithstanding the provisions of Section 4.122(10)(a) and (b), the Development Review Board may require such fencing as shall be deemed necessary to promote and provide traffic safety, noise mitigation, and nuisance abatement, and the compatibility of different uses permitted on adjacent lots of the same zone and on adjacent lots of different zones.*
- D. *Fences in residential zones shall not include barbed wire, razor wire, electrically charged wire, or be constructed of sheathing material such as plywood or flakeboard.*

Response: The site is located within Frog Pond West and is subject to these standards except for the standards of 4.127(0.17) related to the Boeckman Road and Stafford Road frontages. Because the property does not have frontage on Boeckman Road or Stafford Road, the provisions of 4.127(0.17) are not applicable to this proposal. Fences on residential lots are not proposed with this application, but

fences are proposed in stormwater Tracts A and B. As shown on Sheet L2.20, the proposed fences are to prevent the public from accessing the stormwater facilities and provide fall protection. They will be 6 ft. PVC coated chain-link fences and will not include barbed wire, razor wire, or any other material prohibited by this section.

(.09) Corner Vision

Vision clearance shall be provided as specified in Section 4.177, or such additional requirements as specified by the City Engineer.

Response: The provisions of Section 4.177 are addressed in Section V.I of this narrative.

(.10) Prohibited Uses

- A. *Uses of structures and land not specifically permitted in the applicable zoning districts.*
- B. *The use of a trailer, travel trailer or mobile coach as a residence, except as specifically permitted in an approved RV park.*
- C. *Outdoor advertising displays, advertising signs, or advertising structures except as provided in Sections 4.156.05, 4.156.07, 4.156.09, and 4.156.10.*

Response: No prohibited uses are proposed. These provisions are not applicable.

(.11) Accessory Dwelling Units

Accessory Dwelling Units, are permitted subject to standards and requirements of this Subsection. [Amended by Ord. #825, 10/15/18]

Response: No accessory dwelling units are proposed. These standards are not applicable.

(.12) Reduced Setback Agreements

The following procedure has been created to allow the owners of contiguous residential properties to reduce the building setbacks that would typically be required between those properties, or to allow for neighbors to voluntarily waive the solar access provisions of Section 4.137. Setbacks can be reduced to zero through the procedures outlined in this subsection.[...]

Response: No reduced setbacks are requested through these provisions.

(.13) Bed and Breakfasts

Response: No bed and breakfasts are proposed. These standards are not applicable.

C. Section 4.118 Standards Applying in all Planned Development Zones.

(.01) Height Guidelines: *In "S" overlay zones, the solar access provisions of Section 4.137 shall be used to determine maximum building heights. In cases that are subject to review by the Development Review Board, the Board may further regulate heights as follows: [...]*

Response: The subject site is not located within the "S" overlay zone. These standards are not applicable.

(.02) *Underground Utilities shall be governed by Sections 4.300 to 4.320. All utilities above ground shall be located so as to minimize adverse impacts on the site and neighboring properties.*

Response: The provisions of Sections 4.300 to 4.320 are addressed in Section VII of this narrative.

(.03) *Notwithstanding the provisions of Section 4.140 to the contrary, the Development Review Board, in order to implement the purposes and objectives of Section 4.140, and based on findings of fact supported by the record may:*

- A. *Waive the following typical development standards:*
 - 1. *minimum lot area;*
 - 2. *lot width and frontage;*
 - 3. *height and yard requirements;*
 - 4. *lot coverage;*

5. *lot depth;*
 6. *street widths;*
 7. *sidewalk requirements;*
 8. *height of buildings other than signs;*
 9. *parking space configuration and drive aisle design;*
 10. *minimum number of parking or loading spaces;*
 11. *shade tree islands in parking lots, provided that alternative shading is provided;*
 12. *fence height;*
 13. *architectural design standards;*
 14. *transit facilities; and*
 15. *On-site pedestrian access and circulation standards; and*
 16. *Solar access standards, as provided in section 4.137.*
- [Amended by Ord. #719, 6/17/13.]

Response: There are no waivers requested to these standards.

B. The following shall not be waived by the Board, unless there is substantial evidence in the whole record to support a finding that the intent and purpose of the standards will be met in alternative ways:

1. *open space requirements in residential areas;*
2. *minimum density standards of residential zones;*
3. *minimum landscape, buffering, and screening standards;*

Response: The applicant requests two waivers: a waiver to the open space locational requirements of Subdistrict 10 and a waiver to the minimum density of Subdistrict 10.

Open Space

A waiver is requested to locate the minimum required open space in Subdistrict 10/R5 on areas of the subject property that are located within Subdistrict 11/R7. As discussed above, due to the topography of the site and the volume of stormwater to be managed, stormwater facilities are required in addition to LIDA facilities. The most practical location for the site's stormwater facilities is in Subdistrict 10, at the low point of the site, thereby limiting the amount of land available for open space. Locating the open space in Subdistrict 10 would further reduce the area of the district available for residential development and would decrease the number of lots.

As shown on Sheet P2.00, the applicant has proposed a 68,470 sq. ft. active open space, consisting of playground and recreational equipment, and a mature, native tree grove in the northwest corner of the Subdistrict 11/R7 portion of the site.

Due to the higher density and smaller lot sizes in small lot subdistricts, the minimum open space requirement is intended to provide residents with opportunities for outdoor recreation within a close proximity to their property. As provided below in Section IV.E, the proposed Tract E is within 365-ft of Subdistrict 10, and active open space within the Frog Pond Ridge Development to the south is within approximately 400-ft of the Subdistrict. The proximity of available open space and the topographic challenges for stormwater management meet the provisions in 4.127.09.B.2.d to allow a reduction in open space.

Minimum Density

Based on the site's 50 percent proportion of Subdistrict 10, the minimum required density is 15 dwellings. The proposed development includes 12 single family lots in Subdistrict 10, which is three fewer than the minimum requirement. The applicant requests a waiver to the minimum density standards in the Subdistrict 10/R5 zone.

As discussed above in Section III of this report, in addition to the various LIDA facilities dispersed throughout the site (See Sheet L2.30), the most practical placement of the site's stormwater management facilities is in the low elevation areas of the site, which are in Subdistrict 10/R5. These stormwater facilities will manage stormwater from both Subdistricts 10 and 11 on the subject property. Additionally, the proposed development exceeds the minimum density in the Subdistrict 11 portion of the property by one unit.

Due to the street alignments and extensions required by the Frog Pond West Master Plan, the proposed lots in Subdistrict 10 are limited in configuration and location. Proposed Lots 1-6, bound by Street C, SW Frog Pond Lane, Willow Creek Drive, and SW Larkspur Terrace in the SW corner of the subdistrict, are all larger than minimum lot size requirements. An additional lot abutting Street C could meet the minimum 35-ft. width and 60-ft. depth requirement but could not meet the minimum 4,000 sq. ft. lot area standard. The total area of this block, minus Tract A is approximately 28,000 sq. ft. in size. Assessing area alone, there is space to create one additional lot, which would be seven lots. However, given the constraints of the required street system, and the site's logical placement of a stormwater management facility, only six lots are able to practically fit, while meeting minimum lot standards. As a result, the lots, as proposed, are larger than the minimum standard of Subdistrict 10, but are still smaller than those proposed in the medium lot sized Subdistrict 11/R7 portion of the site.

To encourage a mix of housing types, to provide smaller and more affordable properties, and to encourage effective utilization of land, the Frog Pond West Master Plan includes smaller lot subdistricts, with greater minimum density standards, such as Subdistrict 10/R5. The proposed development meets the intent of the Subdistrict 10 density by maximizing the use of the entire site for housing, infrastructure, and open space needs. The applicant is proposing more than the minimum required density in Subdistrict 11/R7 to the north, and, by placing two large stormwater facilities in the most practical space is alleviating the placement of multiple, small stormwater management facilities checked throughout the site.

D. Section 4.124. Standards applying to all Planned Development Residential Zones.

(.01) Examples of principal uses that are typically permitted:

- A. Open Space.
- B. Single-Family Dwelling Units.
- C. Duplexes. [Added by Ord. #825, 10/15/18]
- D. Multiple-Family Dwelling Units. [Amended by Ord. #825, 10/15/18]
- E. Public parks, playgrounds, recreational and community buildings and grounds, tennis courts, and similar recreational uses, all of a non-commercial nature, provided that any principal building or public swimming pool shall be located not less than forty-five (45) feet from any other lot.
- F. Manufactured homes, subject to the standards of Section 4.115 (Manufactured Housing).

Response: The proposed development includes open space and single-family dwelling units. These uses are permitted uses in the PDR zones.

(.02) Permitted accessory uses to single family and detached dwelling units: [Amended by Ord. #825, 10/15/18]

- A. Accessory uses, buildings and structures customarily incidental to any of the principal permitted uses listed above and located on the same lot.
- B. Living quarters without kitchen facilities for persons employed on the premises or for guests. Such facilities shall not be rented or otherwise used as a separate dwelling unless approved as an accessory dwelling unit or duplex.
- C. Accessory dwelling units, subject to the standards of Section 4.113 (.11). [Amended by Ord. #825, 10/15/18]
- D. Home occupations.
- E. A private garage or parking area.
- F. Temporary real estate signs, small announcement or professional signs, and subdivision signs, as provided in the provisions of Sections 4.156.05, 4.156.07, 4.156.09, and 4.156.10. [Amended by Ord. No. 704, 6/18/12]
- G. Temporary buildings for uses incidental to construction work, which buildings shall be removed upon completion or abandonment of the construction work.
- H. Accessory buildings and uses shall conform to front and side yard setback requirements. If the accessory buildings and uses do not exceed 120 square feet or ten (10) feet in height, and they are detached and located behind the rear-most line of the main buildings, the side and rear yard setbacks may be reduced to three (3) feet.
- 10. Livestock and farm animals, subject to the provisions of Section 4.162.

Response: No accessory uses to the proposed detached single-family dwelling units are requested at this time. It is possible that future homes may include accessory buildings, which would be reviewed at the time of building permit.

(.03) Permitted accessory uses for duplexes and attached multiple-family dwelling units:

[Amended by Ord. #825, 10/15/18]

- A. Accessory uses, buildings, and structures customarily incidental to any of the aforesaid principal permitted uses, located on the same lot therewith.
- B. Home occupations.
- C. A private garage or parking area.
- D. Temporary buildings for uses incidental to construction work, which buildings shall be removed upon completion or abandonment of the construction work.
- E. Accessory buildings and uses shall conform to front and side yard setback requirements. If the accessory buildings and uses do not exceed 120 square feet or ten (10) feet in height, and they are detached and located behind the rear-most line of the main buildings, the side and rear yard setbacks may be reduced to three (3) feet.
- F. Livestock and farm animals, subject to the provisions of Section 4.162.

Response: There are no duplexes or multiple-family dwelling units proposed under this application. The criterion is not applicable.

(.05) Appropriate PDR zone based on Comprehensive Plan Density:

Comprehensive Plan Density	Zoning District
0-1 u/acre	PDR-1
2-3 u/acre	PDR-2
4-5 u/acre	PDR-3
6-7 u/acre	PDR-4
10-12 u/acre	PDR-5
16-20 u/acre	PDR-6
20 + u/acre	PDR-7

Table 1: PDR Zone based on Comprehensive Plan Density

**All dwelling unit types, except accessory dwelling units, are included for calculating density.*

[Section 4.124(.05) amended by Ordinance No. 538, 2/21/02.]

Response: The Comprehensive Plan Designation of Residential Neighborhood is implemented by the Residential Neighborhood RN zone. The RN zoning district is not included in the table above.

(.06) Block and access standards:

- 1. Maximum block perimeter in new land divisions: 1,800 feet.
- 2. Maximum spacing between streets or private drives for local access: 530 feet, unless waived by the Development Review Board upon finding that barriers such as railroads, freeways, existing buildings, topographic variations, or designated Significant Resource Overlay Zone areas will prevent street extensions meeting this standard. *[Amended by Ord. 682, 9/9/10]*
- 3. Maximum block length without pedestrian and bicycle crossing: 330 feet, unless waived by the Development Review Board upon finding that barriers such as railroads, freeways, existing buildings, topographic variations, or designated Significant Resource Overlay Zone areas will prevent pedestrian and bicycle facility extensions meeting this standard.

Response: As shown in Sheet P3.00, streets and private drives are located less than 530 ft. apart. As described below in this report, the applicant is requesting maximum block length standards of this section to be waived due to the site's natural and topographic features, and the preservation of mature, native tree groves.

(.07) Signs. *Per the requirements of Sections 4.156.01 through 4.156.11.*

[Amended by Ord. No. 704, 6/18/12]

Response: No signs are currently proposed with this application.

(.08) Parking. *Per the requirements of Section 4.155.*

Response: The standards of 4.155 are addressed in Section V.B of this narrative.

(.09) Corner Vision Clearance. *Per the requirements of Section 4.177.*

Response: The standards of 4.177 are addressed in Section V.I of this narrative.

E. Section 4.127. Residential Neighborhood (RN) Zone.

(.01) Purpose. *The Residential Neighborhood (RN) zone applies to lands within Residential Neighborhood Comprehensive Plan Map designation. The RN zone is a Planned Development zone, subject to applicable Planned Development regulations, except as superseded by this section or in legislative master plans. The purposes of the RN Zone are to:*

- A. Implement the Residential Neighborhood policies and implementation measures of the Comprehensive Plan.*
- B. Implement legislative master plans for areas within the Residential Neighborhood Comprehensive Plan Map designation.*
- C. Create attractive and connected neighborhoods in Wilsonville.*
- D. Regulate and coordinate development to result in cohesive neighborhoods that include: walkable and active streets; a variety of housing appropriate to each neighborhood; connected paths and open spaces; parks and other non-residential uses that are focal points for the community; and, connections to and integration with the larger Wilsonville community.*
- E. Encourage and require quality architectural and community design as defined by the Comprehensive Plan and applicable legislative master plans.*
- F. Provide transportation choices, including active transportation options.*
- G. Preserve and enhance natural resources so that they are an asset to the neighborhoods, and there is visual and physical access to nature.*

Response: Per Figure 5 of the Frog Pond West Master Plan (below), the Frog Pond Oaks site is located within the RN Comprehensive Plan Map designation and is subject to these provisions and to applicable Planned Development regulations of Section 4.118.

Figure 5. Comprehensive Plan Designations

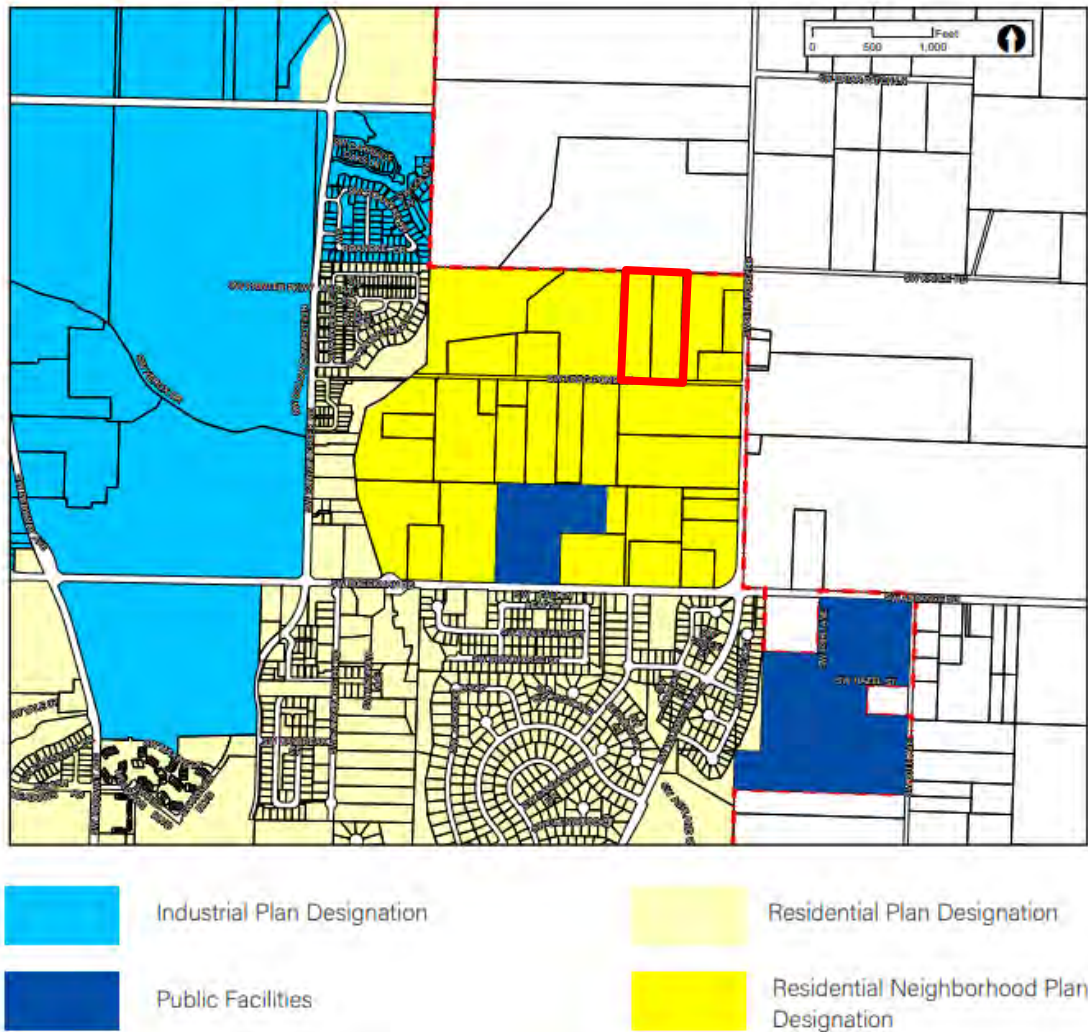

(.02) Permitted uses:

- A. Open Space.
- B. Single-Family Dwelling Unit.
- C. Attached Single-Family Dwelling Unit. In the Frog Pond West Neighborhood, a maximum of 2 dwelling units, not including ADU's [sic], may be attached.
- D. Duplex.
- E. Multiple-Family Dwelling Units, except when not permitted in a legislative master plan, subject to the density standards of the zone. Multi-family dwelling units are not permitted within the Frog Pond West Master Plan area.
- F. Cohousing.
- G. Cluster Housing.
- H. Public or private parks, playgrounds, recreational and community buildings and grounds, tennis courts, and similar recreational uses, all of a non-commercial nature, provided that any principal building or public swimming pool shall be located not less than forty-five (45) feet from any other lot.
- I. Manufactured homes.

Response: As shown on Sheet P2.00, the proposed development includes 41 single-family lots, a 68,470 sq. ft. open space area in Tract E, a 12,414 sq. ft. open space area to the east and north of proposed lots 28-33 in Tract D, and a 2,990 sq. ft. open space area directly east of proposed Lots 13 and 27 in Tract C. None of the proposed lots are anticipated to exceed one dwelling unit and single-family uses are permitted outright in the RN zone.

(.03) Permitted accessory uses to single family dwellings:

- A. *Accessory uses, buildings and structures customarily incidental to any of the principal permitted uses listed above and located on the same lot.*
- B. *Living quarters without kitchen facilities for persons employed on the premises or for guests. Such facilities shall not be rented or otherwise used as a separate dwelling unless approved as an accessory dwelling unit or duplex.*
- C. *Accessory Dwelling Units, subject to the standards of Section 4.113 (.11).*
- D. *Home occupations.*
- E. *A private garage or parking area.*
- F. *Keeping of not more than two (2) roomers or boarders by a resident family.*
- G. *Temporary buildings for uses incidental to construction work, which buildings shall be removed upon completion or abandonment of the construction work.*
- H. *Accessory buildings and uses shall conform to front and side yard setback requirements. If the accessory buildings and uses do not exceed 120 square feet or ten (10) feet in height, and they are detached and located behind the rear-most line of the main buildings, the side and rear yard setbacks may be reduced to three (3) feet.*
- I. *Livestock and farm animals, subject to the provisions of Section 4.162.*

Response: No accessory uses are proposed at this time.

(.04) Uses permitted subject to Conditional Use Permit requirements:

- A. *Public and semi-public buildings and/or structures essential to the physical and economic welfare of an area, such as fire stations, sub-stations and pump stations.*
- B. *Commercial Recreation, including public or private clubs, lodges or meeting halls, golf courses, driving ranges, tennis clubs, community centers and similar commercial recreational uses. Commercial Recreation will be permitted upon a finding that it is compatible with the surrounding residential uses and promotes the creation of an attractive, healthful, efficient and stable environment for living, shopping or working. All such uses except golf courses and tennis courts shall conform to the requirements of Section 4.124(.04)(D) (Neighborhood Commercial Centers).*
- C. *Churches; public, private and parochial schools; public libraries and public museums.*
- D. *Neighborhood Commercial Centers limited to the provisions of goods and services primarily for the convenience of and supported by local residents. Neighborhood Commercial Centers are only permitted where designated on an approved legislative master plan.*

Response: No Conditional Uses are proposed.

(.05) Residential Neighborhood Zone Sub-districts:

- A. *RN Zone sub-districts may be established to provide area-specific regulations that implement legislative master plans.*
 - 1. *For the Frog Pond West Neighborhood, the sub-districts are listed in Table 1 of this code and mapped on Figure 6 of the Frog Pond West Master Plan. The Frog Pond West Master Plan Sub-District Map serves as the official sub-district map for the Frog Pond West Neighborhood.*

Response: The Frog Pond Oaks site is located within the Frog Pond West neighborhood, and includes properties within Subdistricts 10, and 11, as shown in Figure 6 of the Frog Pond West Master Plan (below) and in Table 1 above.

Figure 6. Frog Pond West Land Use and Subdistricts

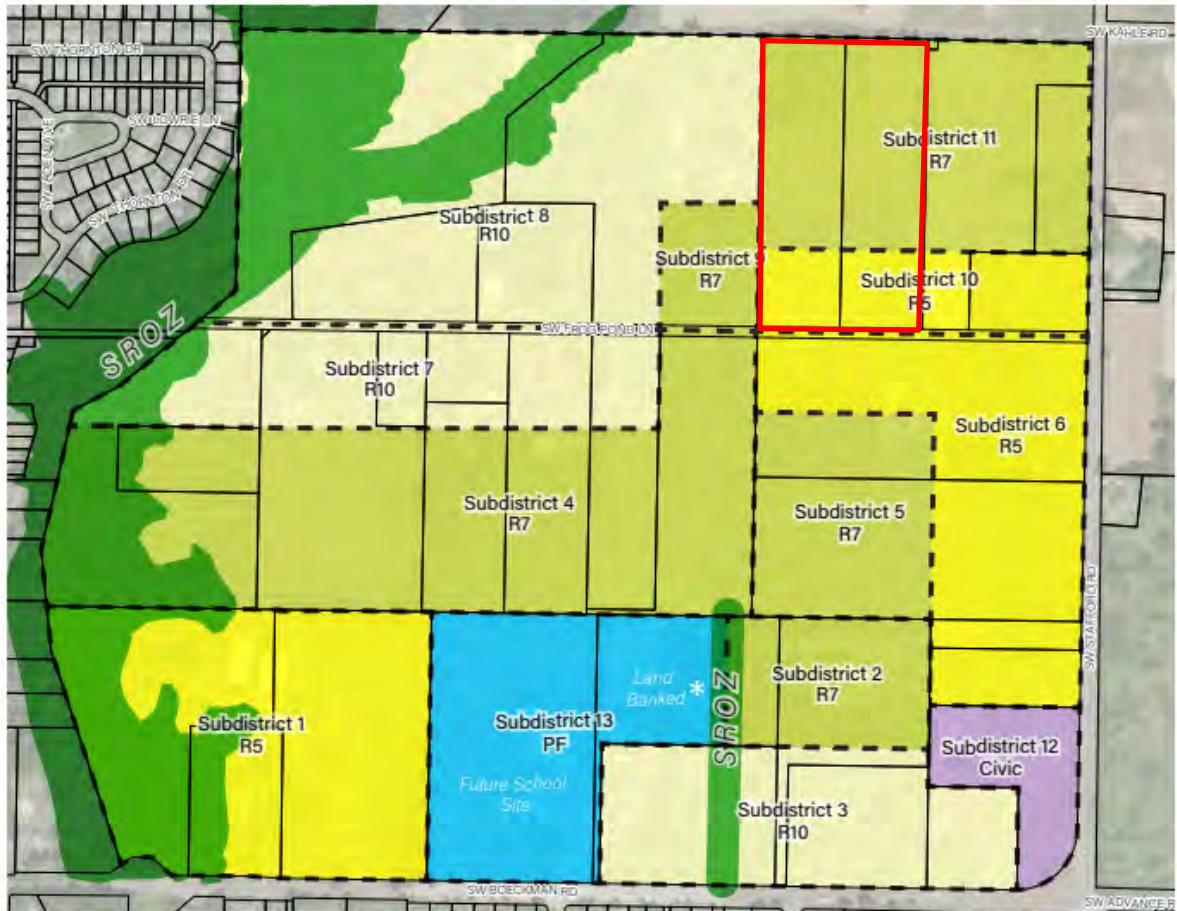

* Land banked for school facilities, a neighborhood park, and/or residential use.

(.06) Minimum and Maximum Residential Units:

- A. The minimum and maximum number of residential units approved shall be consistent with this code and applicable provisions of an approved legislative master plan.
1. For the Frog Pond West Neighborhood, Table 1 in this code and Frog Pond West Master Plan Table 1 establish the minimum and maximum number of residential units for the sub-districts.
 2. For parcels or areas that are a portion of a sub-district, the minimum and maximum number of residential units are established by determining the proportional gross acreage and applying that proportion to the minimums and maximums listed in Table 1. The maximum density on a parcel may be increased, up to a maximum of 10% of what would otherwise be permitted, based on an adjustment to an SROZ boundary that is consistent with 4.139.06.

Response: As indicated in Table 1 above, the proposed Frog Pond Oaks development includes 41 lots, within Subdistricts 10 (R5) and 11 (R7). As previously described above in this narrative, a waiver to the minimum density standards of Subdistrict 10/R5 is requested.

B. The City may allow a reduction in the minimum density for a sub-district when it is demonstrated that the reduction is necessary due to topography, protection of trees, wetlands and other natural resources, constraints posed by existing development, infrastructure needs, provision of non-residential uses and similar physical conditions.

Response: As described above in this report, a waiver is requested to the minimum density standards of Subdistrict 10. Because of the site's constraints, including mature, native tree groves, and the sloping elevation and necessary placement of stormwater management facilities, the applicant is seeking a reduction to the density standards in Subdistrict 10/R5 Zone. This development proposes 12 residential lots in Subdistrict 10, where 15 lots are required. The proposed development meets the Street Demonstration Plan in the Subdistrict 10 portion of the site, which is a high-density local street configuration. The high density street configuration limits the amount of land available to achieve the minimum density standards.

The reduction in density for Subdistrict 10 is necessary due to the infrastructure needs of the streets and the stormwater management facilities. The applicant is able to provide greater density in Subdistrict 11/R7 portion of the site, while achieving the desired benefits aesthetics of a higher density neighborhood.

(.07) Development Standards Generally

A. Unless otherwise specified by this the regulations in this Residential Development Zone chapter, all development must comply with Section 4.113, Standards Applying to Residential Development in Any Zone.

Response: Compliance with applicable regulations of Section 4.113 is addressed in Section IV.B of this narrative. Some regulations of 4.127 supersede the regulations of 4.113.

(.08) Lot Development Standards:

- A. Lot development shall be consistent with this code and applicable provisions of an approved legislative master plan.*
- B. Lot Standards Generally. For the Frog Pond West Neighborhood, Table 2 establishes the lot development standards unless superseded or supplemented by other provisions of the Development Code.*
- C. Lot Standards for Small Lot Sub-districts. The purpose of these standards is to ensure that development in the Small Lot Sub-districts includes varied design that avoids homogenous street frontages, creates active pedestrian street frontages and has open space that is integrated into the development pattern.*
Standards. Planned developments in the Small Lot Sub-districts shall include one or more of the following elements on each block:
 - 1. Alleys.*
 - 2. Residential main entries grouped around a common green or entry courtyard (e.g. cluster housing).*
 - 3. Four or more residential main entries facing a pedestrian connection allowed by an applicable legislative master plan.*
 - 4. Garages recessed at least 4 feet from the front façade or 6 feet from the front of a front porch.*

Response: Table 2 of the Frog Pond Master Plan establishes the following lot development standards for the Frog Pond West neighborhood. These standards supersede the setback standards of 4.113(.03). Lot dimensional standards are applied at the time of subdivision approval, while site development standards (setbacks, height, etc.) are applied at the time of building permit review. This proposal does not include the development of single-family homes or accessory structures.

As shown in Table 3 below, the proposed lots meet the applicable standards.

Table 3: Compliance with Frog Pond West Neighborhood Lot Standards

Standard	Required	Proposed	Required	Proposed	Comments
	R-7 Medium Lot		R-5 Small Lot		
Min Lot Size (Detached SF)	6,000 sf ^A	6,000-7,023 sf	4,000 sf	4,204 – 5,318 sf	Meets standards.
Min Lot Size (Duplex)	NA	NA	NA	NA	NA
Min Lot Depth	60 ft.	91 –130.8 ft.	60 ft	92– 101.5 ft	Meets standards.
Min Lot Width	35 ft	38.9-86.7 ft.	35 ft	36.1 – 49 ft	Meets standards

A. May be reduced to 80% of minimum lot size where necessary to preserve natural resources (e.g. trees, wetlands) and/or provide active open space. Cluster housing may be reduced to 80% of minimum lot size. Duplexes in the R-5 Sub-District have a 6,000 SF minimum lot size.

D. Lot Standards Specific to the Frog Pond West Neighborhood.

1. Lots adjacent to Boeckman Road and Stafford Road shall meet the following standards:

- a. Rear or side yards adjacent to Boeckman Road and Stafford Road shall provide a wall and landscaping consistent with the standards in Figure 10 of the Frog Pond West Master Plan.

Response: The subject property does not abut Stafford Road or Boeckman Road. This standard is not applicable.

2. Lots adjacent to the collector-designated portions of Willow Creek Drive and Frog Pond Lane shall not have driveways accessing lots from these streets unless no practical alternative exists for access. Lots in Large Lot Sub-districts are exempt from this standard.

Response: The southern boundary of the site abuts the Collector designated Frog Pond Lane, and the western boundary of the site abuts the Collector designated Willow Creek Drive. Proposed Lots 1, 6, 20, 21, and 41 have side-yard frontage along SW Frog Pond Lane or SW Willow Creek Drive. Each proposed lot has front lot line frontage abutting the proposed local streets, where the proposed driveways will be located. No driveways are proposed to access this portion of SW Frog Pond Lane or SW Willow Creek Drive. No other proposed lots have frontage along SW Frog Pond Lane or SW Willow Creek Drive, and no driveways are proposed.

(.09) Open Space:

A. Purpose. The purposes of these standards for the Residential Neighborhood Zone are to:

- 1. Provide light, air, open space, and useable recreation facilities to occupants of each residential development.
 - 2. Retain and incorporate natural resources and trees as part of developments.
 - 3. Provide access and connections to trails and adjacent open space areas.
- For Neighborhood Zones which are subject to adopted legislative master plans, the standards work in combination with, and as a supplement to, the park and open space recommendations of those legislative master plans. These standards supersede the Outdoor Recreational Area requirements in WC Section 4.113 (.01) and (.02).

B. Within the Frog Pond West Neighborhood, the following standards apply:

- 1. Properties within the R-10 Large Lot Single Family sub-districts and R-7 Medium Lot Single Family sub-districts are exempt from the requirements of this section. If the Development Review Board finds, based upon substantial evidence in the record, that there is a need for open space, they may waive this exemption and require open space proportional to the need.

Response: As shown in Figure 6 of the Frog Pond West Master Plan, the site consists of properties within the Subdistrict 11 (R7) and Subdistrict 10 (R5). The portion of the site within the Subdistrict 11 is exempt from the requirements of this section.

The portion of the site within the Subdistrict 10 is subject to B.2 below.

2. *For properties within the R-5 Small Lot Single Family sub-districts, Open Space Area shall be provided in the following manner:*

Response: As shown in Figure 6 of the Frog Pond West Master Plan, portions of the site are within the R5 zoned Subdistrict 10 and are subject to the requirements of this section.

- a. *Ten percent (10%) of the net developable area shall be in open space. Net developable area does not include land for non-residential uses, SROZ-regulated lands, streets and private drives, alleys and pedestrian connections. Open space must include at least 50% usable open space as defined by this Code and other like space that the Development Review Board finds will meet the purpose of this section.*

Response: As shown in Table 3 below, the minimum open space for Subdistrict 10/R5 requirement is not met by the proposed development. Due to the proposed location of the stormwater facilities, which serve both Subdistricts 10 and 11, adequate space is not available to meet the minimum open space standards of the Subdistrict 10/R5 zone, while maximizing available housing density for the Subdistrict.

A waiver is requested to allow the minimum open space required in the Subdistrict 10/R5 zone to be located in the Subdistrict 11/R7 zoned portion of the site. As discussed previously in this report, the property slopes from the northern to the southern end of the site before rising into SW Frog Pond Lane. Two larger tracts of land are proposed in the lower-elevation portion of the site, which is in Subdistrict 10/R5. Placing two larger facilities in these locations alleviates the need to place multiple, smaller stormwater facilities throughout the rest of the site.

To meet the intent of the open space standard, the proposed development includes 83,874 sq. ft. of open space within three tracts located in the Subdistrict 11/R7 portion of the site. Tract E is 68,470 sq. ft. in size and includes an established native tree grove which will be preserved and constructed with amenities for community recreational use. Tract E is approximately 365 linear feet from the northwest corner of Subdistrict 10/R5 zone. The proposed development also includes Tracts C and D which are located to the east of proposed lots 13 and 27, and 28-33. Tract D contains established trees that are to be preserved, and both tracts line up to meet open space and a pedestrian accessway proposed with the development directly to the east. Additionally, the R5 portion of the subject property is located approximately 400 linear feet from Tract C in the Frog Pond Ridge Development, which is active open space. The proximity of open space areas located on the subject property and nearby development meet the standards required in subsection (d) below. See Sheet P2.00 for details.

Table 4. Required open space

R-5 Net Developable Site Area (sf)	10% Open Space Required (sf)	Open Space Provided (sf)	Usable Open Space Provided (sf)	Usable Open Space Provided as % of required
79,558	7,956	0	0	0%

- b. *Natural resource areas such as tree groves and/or wetlands, and unfenced low impact development storm water management facilities, may be counted toward the 10% requirement at the discretion of the Development Review Board. Fenced storm water detention facilities do not count toward the open space requirement. Pedestrian connections may also be counted toward the 10% requirement.*

Response: A wetland is present near center of the subject property. The wetland appears to be isolated, with no surface water connections to wetlands off-site, or to roadside ditches adjacent to

the site. There are no tree groves in Subdistrict 10/R5. The proposed stormwater facilities will be fenced. This section is not applicable.

- c. *The minimum land area for an individual open space is 2,000 square feet, unless the Development Review Board finds, based on substantial evidence in the record, that a smaller minimum area adequately fulfills the purpose of this Open Space standard.*

Response: There are three open space tracts in the R7 portion of the site that meet the minimum open space size requirements. Tract E is 68,470 sq. ft. in size and Tract D is 12,414 sq. ft. in size and Tract C is 2,990 sq. ft. in size. The proposed tracts exceed the minimum land area.

- d. *The Development Review Board may reduce or waive the usable open space requirement in accordance with Section 4.118(.03). The Board shall consider substantial evidence regarding the following factors: the walking distance to usable open space adjacent to the subject property or within 500 feet of it; the amount and type of open space available adjacent or within 500 feet of the subject property, including facilities which support creative play.*

Response: A reduction in the open space requirement is requested due to the proposed location of the two stormwater facilities in Tracts A and B, which is the most practical location due to the topography of the subject property, as well as the provision of significant open space in the Subdistrict 11 (R7) portion of the site.

Tract E, which is the large grove of mature trees described above, is approximately 365 linear feet from the northwest corner of Subdistrict 10 (R5) zone. This portion of R5 on the subject property is 400 linear feet from Tract C in the Frog Pond Ridge Development to the south, which is active open space.

The proximity of the site's Subdistrict 10 within 500 feet of existing and proposed open space, coupled with the constraints of this site's topography and mature tree groves, allow the DRB to find that the proposed design is substantially consistent with the Frog Pond West Master Plan and to approve a waiver to the Subdistrict 10/R5 open space requirement.

- e. *The Development Review Board may specify the method of assuring the long-term protection and maintenance of open space and/or recreational areas. Where such protection or maintenance are the responsibility of a private party or homeowners' association, the City Attorney shall review any pertinent bylaws, covenants or agreements prior to recordation.*

Response: Open space and recreational areas will be owned and maintained by the homeowners' association. Pertinent bylaws, covenants, and agreements will be provided to the City prior to plat recordation.

(.10) Block, access and connectivity standards:

- A. *Purpose. These standards are intended to regulate and guide development to create: a cohesive and connected pattern of streets, pedestrian connections and bicycle routes; safe, direct and convenient routes to schools and other community destinations; and, neighborhoods that support active transportation and Safe Routes to Schools.*
- B. *Blocks, access and connectivity shall comply with adopted legislative master plans.*
1. *Within the Frog Pond West Neighborhood, streets shall be consistent with Figure 18, Street Demonstration Plan, in the Frog Pond West Master Plan. The Street Demonstration Plan is intended to be guiding, not binding. Variations from the Street Demonstration Plan may be approved by the Development Review Board, upon finding that one or more of the following justify the variation: barriers such as existing buildings and topography; designated Significant Resource Overlay Zone areas; tree groves, wetlands or other natural resources; existing or planned parks and other active open space that will serve as pedestrian connections for the public; alignment with property lines and ownerships that result in efficient use of land while providing substantially equivalent connectivity for the public; and/or site design that provides substantially equivalent connectivity for the public.*

Response: This standard is a guideline pursuant to WDC Section 4.127(.10)(A). However, the City

can find that the variation from the Street Demonstration Plan for the Frog Pond Oaks planned development provides for the efficient use of land because additional pedestrian connections are unwarranted and because the proposed street and pedestrian connections provide for substantially equivalent connectivity for the public.

As shown in Figure 18, Street Demonstration Plan (below), several public street connections and one pedestrian connection are planned to and through the subject site. Generally, the street network is a modified grid, and access to this area of Frog Pond West is provided by Willow Creek Drive and Frog Pond Lane.

Sheet P8.00 illustrates the proposed blocks, access, and connectivity for Frog Pond Oaks. Willow Creek Drive extends north, intersecting Frog Pond Lane, which connects the north-south Larkspur Terrace and Marigold Terrace Proposed Local Streets C and D provide multi-modal connections extending east-west for the full width of the site, and will continue eastward as the adjacent property to the east is developed.

On the west side of the subject property, SW Willow Creek Drive will be extended north from Frog Pond Lane to a connection with Street C and then to Street D, where it will then track west to avoid the mature, native tree grove in Tract E. Tract E will contain pedestrian connections joining the Khale Road right-of-way, the location of the future Boeckman Creek Trail, and connections to Tract D. These street extensions and the pedestrian/open space proposed on the east side of the subject property provide the network of connectivity in substantial conformance to the Frog Pond West Master Plan.

The proposed Tract C, extending northward from Street C, on the eastern edge of the subject property, connects to Street D before continuing northward through an existing native tree grove to the east and north boundary of the subject property in Tract D. Both Tracts C and D will meet as open space to connect to a pedestrian path included in a development project proposed on the property directly east. This pedestrian connection will preserve existing, mature trees, and be planted with five Pyramidal European Hornbeam trees, meeting the requirements for pedestrian connections in the Frog Pond West Master Plan. This connection helps the development achieve substantial conformance with the Frog Pond West Master Plan Street Demonstration plan, by providing a pleasant park-like pedestrian connection, while also preserving existing, mature trees.

The proposed street and pedestrian pattern differ from the Street Demonstration Plan in three respects:

- SW Larkspur Terrace does not continue north after reaching internal Street C, as shown in Sheet P2.00.
- The proposed westerly shift of the north-south Willow Creek Drive to avoid a grove of existing, mature trees (Tract E).
- Internal Street E (north south) is shifted to the east to avoid the mature grove of trees.

The Street Demonstration Plan shows SW Larkspur Terrace extending north from SW Frog Pond Lane through to future Khale Road, and SW Willow Creek Drive extending directly north to future Khale Road, rather than shifting west as proposed. Extending SW Willow Creek Drive will require the removal of several mature trees, including 52", 38", 28", 25" and a 34" DBH Oregon White Oaks, and several Scots Pine trees (12"-16" DBH). Likewise, if Street E were to be placed as shown on the Street Demonstration Plan, it would require the removal of a 22" DBH Oregon White Oak, and a 36" and 29" DBH Ponderosa Pine. See Sheet L1.00 for details.

Between pedestrian connection in Tract C and SW Willow Creek Drive are Lots 13-27, and the block length is approximately 448 feet. By extending SW Larkspur Terrace, or creating a separate, mid-block pedestrian connection between Streets C and D, the development would need to reduce the number of lots by two, which will bring the portion of the site in Subdistrict 11/R7 out of compliance with Frog Pond West Master Plan density standards.

Due to the natural/topographical constraints of the site, the infrastructure requirements of the Street Demonstration Plan, and the preservation of the native tree grove in Tract E, the proposed pedestrian connections and street layout conform to standards established in the Frog Pond West Master Plan, while allowing the site to more closely achieve compliance with density standards.

As explained above, the City can find that the modified grid pattern subdivision plan provides an

efficient street connection to Willow Creek Road and Frog Pond Lane and that interior streets will then provide efficient pedestrian connections through paths, proposed open space, and the attached sidewalks. Because of the efficient grid pattern, the City can find that the proposed subdivision street plan with attached sidewalks provides for a substantially equivalent level of pedestrian connectivity.

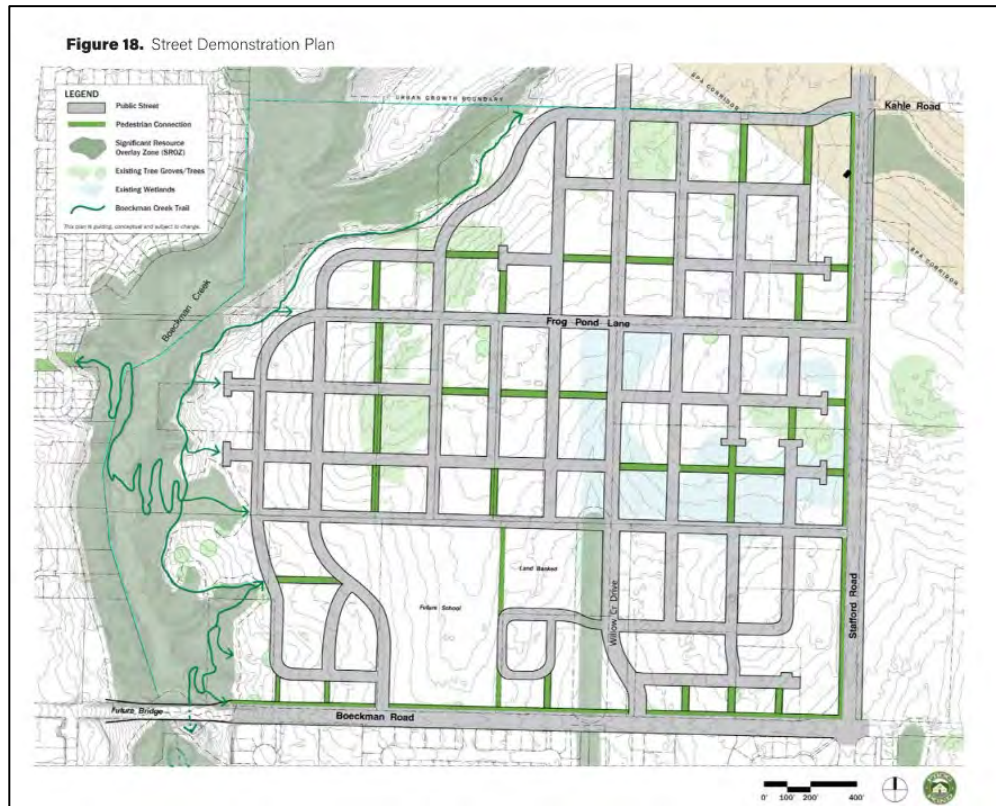

(.011) Signs. Per the requirements of Sections 4.156.01 through 4.156.11 and applicable provisions from adopted legislative master plans.

Response: The requirements of Sections 4.156.01 through 4.156.11 are addressed in Section V.C of this narrative.

(.012) Parking. Per the requirements of Section 4.155 and applicable provisions from adopted legislative master plans.

Response: The requirements of Section 4.155 are addressed in Section V.B of this narrative. The adopted legislative master plan applicable to this site is the Frog Pond West Master Plan, which has been codified in the zoning ordinance.

(.013) Corner Vision Clearance. Per the requirements of Section 4.177.

Response: The requirements of Section 4.177 are addressed in Section V of this narrative.

(.014) Main Entrance Standards

A. Purpose. These standards:

1. Support a physical and visual connection between the living area of the residence and the street;
2. Enhance public safety for residents and visitors and provide opportunities for community interaction;
3. Ensure that the pedestrian entrance is visible or clearly identifiable from the street by its orientation or articulation; and
4. Ensure a connection to the public realm for development on lots fronting both private and public streets by making the pedestrian entrance visible or clearly identifiable from the public street.

- B. *Location. At least one main entrance for each structure must:*
1. *Be within 12 feet of the longest street-facing front wall of the dwelling unit; and*
 2. *Either:*
 - a. *Face the street*
 - b. *Be at an angle of up to 45 degrees from the street; or*
 - c. *Open onto a porch. The porch must:*
 - (i) *Be at least 6 feet deep*
 - (ii) *Have at least one entrance facing the street; and*
 - (iii) *Be covered with a roof or trellis*

Response: The individual dwelling designs will be reviewed at the time of building permit submittal. As shown in Appendix H, all example dwellings will include a main entrance that meets the standards of this section.

(.015) Garage Standards

- A. *Purpose. These standards:*
1. *Ensure that there is a physical and visual connection between the living area of the residence and the street;*
 2. *Ensure that the location and amount of the living area of the residence, as seen from the street, is more prominent than the garage;*
 3. *Prevent garages from obscuring the main entrance from the street and ensure that the main entrance for pedestrians, rather than automobiles, is the prominent entrance;*
 4. *Provide for a pleasant pedestrian environment by preventing garages and vehicle areas from dominating the views of the neighborhood from the sidewalk; and*
 5. *Enhance public safety by preventing garages from blocking views of the street from inside the residence.*
- B. *Street-Facing Garage Walls*
1. *Where these regulations apply. Unless exempted, the regulations of this subsection apply to garages accessory to residential units.*
 2. *Exemptions:*
 - a. *Garages on flag lots.*
 - b. *Development on lots which slope up or down from the street with an average slope of 20 percent or more.*
 3. *Standards.*
 - a. *The length of the garage wall facing the street may be up to 50 percent of the length of the street-facing building façade. For duplexes, this standard applies to the total length of the street-facing façades. For all other lots and structures, the standards apply to the street-facing façade of each unit. For corner lots, this standard applies to only one street side of the lot. For lots less than 50 feet wide at the front lot line, the standard in (b) below applies.*
 - b. *For lots less than 50 wide at the front lot line, the following standards apply:*
 - (i) *The width of the garage door may be up to 50 percent of the length of the street-facing façade.*
 - (ii) *The garage door must be recessed at least 4 feet from the front façade or 6 feet from the front of a front porch.*
 - (iii) *The maximum driveway width is 18 feet.*
 - a. *Where a dwelling abuts a rear or side alley or a shared driveway, the garage shall orient to the alley or shared drive.*
 - b. *Where three or more contiguous garage parking bays are proposed facing the same street, the garage opening closest to a side property line shall be recessed at least two feet behind the adjacent opening(s) to break up the street facing elevation and diminish the appearance of the garage from the street. Side-loaded garages, i.e., where the garage openings are turned away from the street, are exempt from this requirement.*
 - c. *A garage entry that faces a street may be no closer to the street than the longest street facing wall of the dwelling unit. There must be at least 20 feet between the garage door and the sidewalk. This standard does not apply to garage entries that do not face the street.*

Response: As shown on Sheet P2.00, there are no proposed alleys. All proposed lots will be accessed from local streets.

The individual dwelling designs will be reviewed at the time of building permit submittal. As shown on the plan sheets in Appendix H, all example dwellings will include garages that meet the standards of this section. Per Sheet P2.00, all driveways on lots less than 50-ft in width are less than 18-ft wide.

(0.16) Residential Design Standards

A. *Purpose. These standards:*

1. *Support consistent quality standards so that each home contributes to the quality and cohesion of the larger neighborhood and community.*
2. *Support the creation of architecturally varied homes, blocks and neighborhoods, whether a neighborhood develops all at once or one lot at a time, avoiding homogeneous street frontages that detract from the community's appearance.*

B. *Applicability. These standards apply to all façades facing streets, pedestrian connections, or elsewhere as required by this Code or the Development Review Board. Exemptions from these standards include: (1) Additions or alterations adding less than 50% to the existing floor area of the structure; and, (2) Additions or alterations not facing a street.*

Response: All proposed dwelling façades will face streets or pedestrian connections and are subject to these standards.

C. *Windows. The standards for minimum percentage of façade surface area in windows are below. These standards apply only to facades facing streets and pedestrian connections.*

1. *For two-story homes:*
 - a. *15% - front facades*
 - b. *12.5% – front facades if a minimum of six (6) design elements are provided per Section 4.127 (0.15) E, Design Menu.*
 - c. *10% - front facades facing streets if a minimum of seven (7) design elements are provided per Section 4.127 (0.15) E, Design Menu.*
2. *For one-story homes:*
 - a. *12.5% - front facades*
 - b. *10 % – front facades if a minimum of six (6) design elements are provided per Section 4.127 (0.15) E, Design Menu.*
3. *For all homes: 5% for street-side facades.*
4. *Windows used to meet this standard must provide views from the building to the street. Glass block does not meet this standard. Windows in garage doors and other doors count toward this standard.*

Response: The individual dwelling designs will be reviewed at the time of building permit submittal. As shown in Appendix H, all example dwellings will include windows that meet the standards of this section.

D. *Articulation. Plans for residential buildings shall incorporate design features such as varying rooflines, offsets, balconies, projections (e.g., overhangs, porches, or similar features), recessed or covered entrances, window reveals, or similar elements that break up otherwise long, uninterrupted elevations. Such elements shall occur at a minimum interval of 30 feet on façades facing streets, pedestrian connections, or elsewhere as required by this Code or the Development Review Board. Where a façade governed by this standard is less than 30 feet in length, at least one of the above-cited features shall be provided.*

Response: The individual dwelling designs will be reviewed at the time of building permit submittal. As shown in Appendix H, all example dwellings will include articulation design features that meet the standards of this section.

E. *Residential Design Menu. Residential structures shall provide a minimum of five (5) of the design elements listed below for front facades, unless otherwise specified by the code. For side facades facing streets or pedestrian connections, a minimum of three (3) of the design elements must be provided. Where a design features includes more than one element, it is counted as only one of the five required elements.*

1. *Dormers at least three (3) feet wide.*
2. *Covered porch entry – minimum 48 square foot covered front porch, minimum six (6) feet deep and minimum of a six (6) foot deep cover. A covered front stoop with minimum 24 square foot area, 4 foot depth and hand rails meets this standard.*

3. *Front porch railing around at least two (2) sides of the porch.*
4. *Front facing second story balcony – projecting from the wall of the building a minimum of four (4) feet and enclosed by a railing or parapet wall.*
5. *Roof overhang of 16 inches or greater.*
6. *Columns, pillars or posts at least four (4) inches wide and containing larger base materials.*
7. *Decorative gables – cross or diagonal bracing, shingles, trim, corbels, exposed rafter ends or brackets (does not include a garage gable if garage projects beyond dwelling unit portion of street façade).*
8. *Decorative molding above windows and doors.*
9. *Decorative pilaster or chimneys.*
10. *Shakes, shingles, brick, stone or other similar decorative materials occupying at least 60 square feet of the street façade.*
11. *Bay or bow windows – extending a minimum of 12 inches outward from the main wall of a building and forming a bay or alcove in a room within the building.*
12. *Sidelight and/or transom windows associated with the front door or windows in the front door.*
13. *Window grids on all façade windows (excluding any windows in the garage door or front door).*
14. *Maximum nine (9) foot wide garage doors or a garage door designed to resemble two (2) smaller garage doors and/or windows in the garage door (only applicable to street facing garages).*
15. *Decorative base materials such as natural stone, cultured stone or brick extending at least 36 inches above adjacent finished grade occupying a minimum of 10 % of the overall primary street facing façade.*
16. *Entry courtyards which are visible from, and connected directly to, the street. Courtyards shall have a minimum depth of 10 feet and minimum width of 80% of the non-garage/driveway building width to be counted as a design element.*

Response: Each of the proposed detached residential structures will include at least five of the listed elements on the front-facing elevations and three of the listed elements on façades facing sidewalks illustrated in Sheet P8.00 and Appendix H.

F. House Plan Variety. No two directly adjacent or opposite dwelling units may possess the same front or street-facing elevation. This standard is met when front or street-facing elevations differ from one another due to different materials, articulation, roof type, inclusion of a porch, fenestration, and/or number of stories. Where façades repeat on the same block face, they must have at least three intervening lots between them that meet the above standard. Small Lot developments over 10 acres shall include duplexes and/or attached 2-unit single family homes comprising 10% of the homes – corner locations are preferred.

Response: Appendix H illustrates examples of home designs. Eight different detached dwelling types are provided, and they will not be repeated on adjacent or opposite lots along the same street frontage. This standard will be verified at the time of building permit submittal.

G. Prohibited Building Materials. The following construction materials may not be used as an exterior finish:

1. *Vinyl siding.*
2. *Wood fiber hardboard siding.*
3. *Oriented strand board siding.*
4. *Corrugated or ribbed metal.*
5. *Fiberglass panels.*

Response: As shown in Appendix H, no prohibited building materials are proposed. Conformance with these standards will be verified at the time of building permit submittal.

(0.17) Fences

- A. Within Frog Pond West, fences shall comply with standards in 4.113 (.08) except as follows:*
1. *Columns for the brick wall along Boeckman Road and Stafford Road shall be placed at lot corners where possible.*
 2. *A solid fence taller than 4 feet in height is not permitted within 8 feet of the brick wall along Boeckman Road and Stafford Road, except for fences placed on the side lot line that are perpendicular to the brick wall and end at a column of the brick wall.*
 3. *Height transitions for fences shall occur at fence posts.*

Response: As shown in Sheet L2.20, Tracts A and B are proposed along Frog Pond Lane. Tracts A and B will be stormwater management facilities with 6-ft tall, PVC coated, chain-link fences meeting the requirements of this section. See Sheet L2.20.

(0.18) Homes Adjacent to Schools, Parks and Public Open Spaces

A. *Purpose.* The purpose of these standards is to ensure that development adjacent to schools and parks is designed to enhance those public spaces with quality design that emphasizes active and safe use by people and is not dominated by driveways, fences, garages, and parking.

B. *Applicability.* These standards apply to development that is adjacent to or faces schools and parks. As used here, the term adjacent includes development that is across a street or pedestrian connection from a school or park.

Response: Lots 34-41 are adjacent to private open space Tract E, and lots 28-33 are adjacent to private open space, Tract D. These lots are not subject to these standards. However, the applicant intends to create an attractive appearance for open space users.

C. *Development must utilize one or more of the following design elements:*

1. *Alley loaded garage access.*

2. *On corner lots, placement of the garage and driveway on the side street that does not face the school, park, or public open space.*

3. *Recess of the garage a minimum of four feet from the front façade of the home. A second story above the garage, with windows, is encouraged for this option.*

Response: As noted above, the subject lots are adjacent to private, rather than public, open space. These standards are not applicable but will be considered during home plan selection.

D. *Development must be oriented so that the fronts or sides of homes face adjacent schools or parks. Rear yards and rear fences may generally not face the schools or parks, unless approved through the waiver process of 4.118 upon a finding that there is no practicable alternative due to the size, shape or other physical constraint of the subject property.*

Response: None of the proposed lots face schools or public parks. As noted above, the subject lots are adjacent to private, rather than public, open space. These standards are not applicable but will be considered during home plan selection.

F. Section 4.139. Significant Resource Overlay Zone (SROZ) Ordinance.

[...]

Section 4.139.10 Development Review Board (DRB) Process

[...]

(.02) *Adding Wetlands.* Except for water quality or storm water detention facilities, the City shall initiate amendments to the Significant Resource Overlay Zone maps to add wetlands when the City receives significant evidence that a wetland meets any one of the following criteria:

A. *The wetland is fed by surface flows, sheet flows or precipitation, and has evidence of flooding during the growing season, and has 60 percent or greater vegetated cover, and is over one-half acre in size; or the wetland qualifies as having intact water quality function under the 1996 Oregon Freshwater Wetland Assessment Methodology; or*

Response: As noted in the AKS report included as Appendix D: "A palustrine emergent (PEM) wetland was located on the subject property (see Appendix E [of the AKS wetland delineation report]). The wetland on the site totals 0.80 acres in size. The wetland is primarily fed by subsurface lateral flow and is not fed by surface or sheet flows. The wetland does not flood during the growing season; it is only seasonally saturated. There was no evidence of inundation (no algal matting, unvegetated bare areas, or soil cracking) during our early springtime site visit (March 2021). Under the 1996 Oregon Freshwater Assessment Methodology (OFWAM), the wetland does not have an intact water quality control function."

B. *The wetland is in the Metro Title 3 Flood Management Area as corrected by the most current FEMA Flood Insurance Rate Maps, and has evidence of flooding during the growing season, and is five acres or more in size, and has a restricted outlet or no outlet; or the wetland qualifies as having intact hydrologic control function under the 1996 Oregon Freshwater Wetland Assessment Methodology; or*

Response: As noted in the AKS report included as Appendix D: “Wetland delineated on the site is not mapped within a current Federal Emergency Management Agency (FEMA) Flood Management Area. According to OFWAM, the wetland does not have an intact hydrologic control function (see OFWAM worksheets included in Appendix B). There was no evidence of flooding during the growing season, the wetland area is less than 5 acres in size and lacks an outlet to waters.”

C. *The wetland or a portion of the wetland is within a horizontal distance of less than one - fourth mile from a water body which meets the Department of Environmental Quality definition of water quality limited water body in OAR Chapter 340, Division 41 (1996).*

Response: As noted in the AKS report included as Appendix D: “Wetland on the project site is located greater than ¼-mile from an Oregon Department of Environmental Quality (DEQ) water quality limited listed water body. The Willamette River is the closest water quality limited water body, which is located over 1 mile from the project site.”

D. *Created or restored wetlands that meet the requirements of Section 4.139.10(.02) shall be added to the Significant Resource Overlay Zone. [Added by Ord. # 674 11/16/09].*

Response: As noted in the AKS report included as Appendix D: “The wetland found on the project site was not created or restored under requirements of section 4.139.10(.02) of City’s SROZ ordinance.”

(.03) Development of structures, additions and improvements that relate to uses other than single family residential.

Response: No development of structures, additions and improvements for uses other than single family residential are proposed. This standard is not applicable.

*(.04) **Variances.** A variance may be taken to any of the provisions of this Section per the standards of Section 4.196 of the Planning and Land Development Ordinance.*

Response: No variances are being requested.

Section 4.139.11 Special Provisions

*(.01) **Reduced front, rear and side yard setback.** Applications on properties containing the SROZ may reduce the front, rear and side yard setback for developments or additions to protect the significant resource, as approved by the Development Review Board.*

*(.02) **Density Transfer.** For residential development proposals on lands which contain the SROZ, a transfer of density shall be permitted within the development proposal site. The following formula shall be used to calculate the density that shall be permitted for allowed residential use on the property:*

A. *Step 1. Calculate Expected Maximum Density. The Expected Maximum Density (EMD) is calculated by multiplying the acreage of the property by the maximum density permitted in the Wilsonville Comprehensive Plan.*

B. *Step 2. The density that shall be permitted on the property shall be equal to the EMD obtained in Step 1, provided:*

- 1. The density credit can only be transferred to that portion of the development site that is not located within the designated Significant Resource; and*
- 2. 50% of the maximum number of dwelling units that are within the SROZ are allowed to be transferred to the buildable portion of the proposed development site provided that the standards for outdoor living area, landscaping, building height and parking shall still be met. Applicants proposing a density transfer must demonstrate compatibility between adjacent properties as well as satisfy the setback requirements of the zone in which the development is proposed or meet Section 4.139.10 A. above; and*
- 3. The types of residential uses and other applicable standards permitted in the zone shall remain the same; and*
- 4. Land area within the Significant Resource Overlay Zone may be used to satisfy the requirements for outdoor recreation/open space area consistent with the provisions found in Section 4.113 of the Planning and Land Development Ordinance.*

Response: No setback reductions or density transfers are proposed per these special provisions.

*(.03) **Alteration of constructed drainageways.** Alteration of constructed drainageways may be allowed provided that such alterations do not adversely impact stream flows, flood storage capacity and in stream water quality and provide more efficient use of the land as well as provide improved habitat value*

through mitigation, enhancement and/or restoration. Such alterations must be evaluated through an SRIR and approved by the City Engineer and Development Review Board.

Response: No alteration of constructed drainageways is proposed.

G. Section 4.140. Planned Development Regulations.

(.01) Purpose .

- A. *The provisions of Section 4.140 shall be known as the Planned Development Regulations. The purposes of these regulations are to encourage the development of tracts of land sufficiently large to allow for comprehensive master planning, and to provide flexibility in the application of certain regulations in a manner consistent with the intent of the Comprehensive Plan and general provisions of the zoning regulations and to encourage a harmonious variety of uses through mixed use design within specific developments thereby promoting the economy of shared public services and facilities and a variety of complimentary activities consistent with the land use designation on the Comprehensive Plan and the creation of an attractive, healthful, efficient and stable environment for living, shopping or working.*
- B. *It is the further purpose of the following Section:*
1. *To take advantage of advances in technology, architectural design, and functional land use design;*
 2. *To recognize the problems of population density, distribution and circulation and to allow a deviation from rigid established patterns of land uses, but controlled by defined policies and objectives detailed in the comprehensive plan;*
 3. *To produce a comprehensive development equal to or better than that resulting from traditional lot land use development.*
 4. *To permit flexibility of design in the placement and uses of buildings and open spaces, circulation facilities and off-street parking areas, and to more efficiently utilize potentials of sites characterized by special features of geography, topography, size or shape or characterized by problems of flood hazard, severe soil limitations, or other hazards;*
 5. *To permit flexibility in the height of buildings while maintaining a ratio of site area to dwelling units that is consistent with the densities established by the Comprehensive Plan and the intent of the Plan to provide open space, outdoor living area and buffering of low-density development.*
 6. *To allow development only where necessary and adequate services and facilities are available or provisions have been made to provide these services and facilities.*
 7. *To permit mixed uses where it can clearly be demonstrated to be of benefit to the users and can be shown to be consistent with the intent of the Comprehensive Plan.*
 8. *To allow flexibility and innovation in adapting to changes in the economic and technological climate.*

Response: The applicant requests a waiver to the minimum density standards and the minimum open space requirements in the R5 Subdistrict 10. The Frog Pond West Master Plan, a chapter of the Comprehensive Plan, identifies an area that is sufficiently large to allow for master planning of the Frog Pond West area. The Frog Pond West Master Plan identifies the location of infrastructure including arterial and collector roads, utilities, parks, and schools.

As part of the proposed Frog Pond Oaks development, the Willow Creek Dr alignment was shifted to the west to preserve a mature tree grove on the NW portion of the subject property, which will be used as open space for the Frog Pond community. As presented above in this report, the use of this portion of the property as open space serves to mitigate the requested reduction in open space land area in the Subdistrict 10/R5 portion.

The waiver to minimum density requirements in Subdistrict 10, as discussed previously in this report, is requested due to proposed placement of the sites two large stormwater facilities. As a mitigating factor, the site will include open space areas in the northwestern portion and along the eastern property boundary.

The waivers would meet the purpose of the Planned Development Zones by providing flexibility and allowing a site design that is able to respond to site characteristics.

(.02) Lot Qualification.

- A. *Planned Development may be established on lots which are suitable for and of a size to be planned and developed in a manner consistent with the purposes and objectives of Section 4.140.*
- B. *Any site designated for development in the Comprehensive Plan may be developed as a Planned Development, provided that it is zoned "PD." All sites which are greater than two (2) acres in size, and designated in the Comprehensive Plan for commercial, residential, or industrial use shall be developed as Planned Developments, unless approved for other uses permitted by the Development Code. Smaller sites may also be developed through the City's PD procedures, provided that the location, size, lot configuration, topography, open space and natural vegetation of the site warrant such development.*

Response: The subject site is 10.46 acres in area and is designated in the Comprehensive Plan for residential use. The proposed development will be developed as a residential Planned Development per the provisions of this section.

(.03) Ownership.

- A. *The tract or tracts of land included in a proposed Planned Development must be in one (1) ownership or control or the subject of a joint application by the owners of all the property included. The holder of a written option to purchase, with written authorization by the owner to make applications, shall be deemed the owner of such land for the purposes of Section 4.140.*
- B. *Unless otherwise provided as a condition for approval of a Planned Development permit, the permittee may divide and transfer units or parcels of any development. The transferee shall use and maintain each such unit or parcel in strict conformance with the approval permit and development plan.*

Response: The owner of the subject properties has signed the application forms required for this development proposal.

(.04) Professional Design.

- A. *The applicant for all proposed Planned Developments shall certify that the professional services of the appropriate professionals have been utilized in the planning process for development.*
- B. *Appropriate professionals shall include, but not be limited to the following to provide the elements of the planning process set out in Section 4.139:*
 - 1. *An architect licensed by the State of Oregon;*
 - 2. *A landscape architect registered by the State of Oregon;*
 - 3. *An urban planner holding full membership in the American Institute of Certified Planners, or a professional planner with prior experience representing clients before the Development Review Board, Planning Commission, or City Council; or*
 - 4. *A registered engineer or a land surveyor licensed by the State of Oregon.*
- C. *One of the professional consultants chosen by the applicant from either 1, 2, or 3, above, shall be designated to be responsible for conferring with the planning staff with respect to the concept and details of the plan.*
- D. *The selection of the professional coordinator of the design team will not limit the owner or the developer in consulting with the planning staff.*

Response: The development team includes Mike Peebles, PE; Keith Buisman, PE; Rose Horton, PE; Steve Dixon, PLA; Gabriel Kruse, PLA; and Li Alligood, AICP. Li Alligood has been designated as the applicant's representative and party responsible for conferring with the planning staff.

(.05) Planned Development Permit Process.

- A. *All parcels of land exceeding two (2) acres in size that are to be used for residential, commercial or industrial development, shall, prior to the issuance of any building permit:*
 - 1. *Be zoned for planned development;*
 - 2. *Obtain a planned development permit; and*
 - 3. *Obtain Development Review Board, or, on appeal, City Council approval.*

Response: The subject site exceeds 2 acres in size and is proposed for residential development. This application includes a zoning map amendment to apply the RN zone to the site; Planned Development Stage I application; and Planned Development Stage II application.

- B. *Zone change and amendment to the zoning map are governed by the applicable provisions of the Zoning Sections, inclusive of Section 4.197.*

Response: The requested zoning map amendment is subject to the applicable provisions of the Zoning Sections and 4.197. These provisions are addressed in Sections IV and V of this narrative.

C. *Development Review Board approval is governed by Sections 4.400 to 4.450*

D. *All planned developments require a planned development permit. The planned development permit review and approval process consists of the following multiple stages, the last two or three of which can be combined at the request of the applicant:*

1. *Pre-application conference with Planning Department;*
2. *Preliminary (Stage I) review by the Development Review Board. When a zone change is necessary, application for such change shall be made simultaneously with an application for preliminary approval to the Board; and*
3. *Final (Stage II) review by the Development Review Board*
4. *In the case of a zone change and zone boundary amendment, City Council approval is required to authorize a Stage I preliminary plan.*

Response: A pre-application conference was held with the Planning Department on July 1, 2021. Concurrent zoning map amendment, Stage I, and Stage II applications (and a number of additional concurrent applications) have been submitted for review by the DRB.

[...]

(.07) Preliminary Approval (Stage One):

A. *Applications for preliminary approval for planned developments shall:*

1. *Be made by the owner of all affected property or the owner's authorized agent; and*
2. *Be filed on a form prescribed by the City Planning Department and filed with said Department.*
3. *Set forth the professional coordinator and professional design team as provided in subsection (.04), above.*
4. *State whether the development will include mixed land uses, and if so, what uses and in what proportions and locations.*

Response: This submittal includes all the above information.

B. *The application shall include conceptual and quantitatively accurate representations of the entire development sufficient to judge the scope, size, and impact of the development on the community; and, in addition to the requirements set forth in Section 4.035, shall be accompanied by the following information:*

1. *A boundary survey or a certified boundary description by a registered engineer or licensed surveyor.*
2. *Topographic information as set forth in Section 4.035*
3. *A tabulation of the land area to be devoted to various uses, and a calculation of the average residential density per net acre.*
4. *A stage development schedule demonstrating that the developer intends receive Stage II approval within two (2) years of receiving Stage I approval, and to commence construction within two (2) years after the approval of the final development plan, and will proceed diligently to completion; unless a phased development schedule has been approved; in which case adherence to that schedule shall be considered to constitute diligent pursuit of project completion.*
5. *A commitment by the applicant to provide in the Final Approval (Stage II) a performance bond or other acceptable security for the capital improvements required by the project.*
6. *If it is proposed that the final development plan will be executed in stages, a schedule thereof shall be provided.*
7. *Statement of anticipated waivers from any of the applicable site development standards.*

Response: A boundary survey including topographic information is included as Sheet P1.10. A tabulation of land area and residential density is included in Table 1 within this narrative. Stage I and Stage II approvals are being requested concurrently, and a stage development schedule is not proposed. The applicant is requesting waivers to some density and open space requirements, which are described elsewhere in this narrative.

(.09) Final Approval (Stage Two):

[Note: Outline Number is incorrect.]

- A. *Unless an extension has been granted by the Development Review Board, within two (2) years after the approval or modified approval of a preliminary development plan (Stage I), the applicant shall file with the City Planning Department a final plan for the entire development or when submission in stages has been authorized pursuant to Section 4.035 for the first unit of the development, a public hearing shall be held on each such application as provided in Section 4.013.*

Response: A Stage II application has been submitted concurrent with the Stage I application.

- B. *After such hearing, the Development Review Board shall determine whether the proposal conforms to the permit criteria set forth in this Code, and shall approve, conditionally approve, or disapprove the application.*
- C. *The final plan shall conform in all major respects with the approved preliminary development plan, and shall include all information included in the preliminary plan plus the following:*
1. *The location of water, sewerage and drainage facilities;*
 2. *Preliminary building and landscaping plans and elevations, sufficient to indicate the general character of the development;*
 3. *The general type and location of signs;*
 4. *Topographic information as set forth in Section 4.035;*
 5. *A map indicating the types and locations of all proposed uses; and*
 6. *A grading plan.*

Response: A Preliminary Utility Plan is included as Sheet P4.00. Preliminary building elevations are included as Appendix H. Preliminary landscaping plans are included as Sheets L2.00-L2.40. A Preliminary Grading Plan is included as Sheet P5.00. Sign locations and permits will be provided under separate application.

- D. *The final plan shall be sufficiently detailed to indicate fully the ultimate operation and appearance of the development or phase of development. However, Site Design Review is a separate and more detailed review of proposed design features, subject to the standards of Section 4.400.*

Response: A concurrent Site Design Review application has been submitted. Section 4.400 Site Design Review criteria are addressed in Section VIII of this narrative.

- E. *Copies of legal documents required by the Development Review Board for dedication or reservation of public facilities, or for the creation of a non-profit homeowner's association, shall also be submitted.*

Response: The recorded Declaration of Protective Covenants, Conditions, Restrictions and Easements for Stafford Meadows is included as Appendix G. Frog Pond Oaks will be annexed into the existing Homeowners Association (HOA).

[...]

- J. *A planned development permit may be granted by the Development Review Board only if it is found that the development conforms to all the following criteria, as well as to the Planned Development Regulations in Section 4.140:*
1. *The location, design, size and uses, both separately and as a whole, are consistent with the Comprehensive Plan, and with any other applicable plan, development map or Ordinance adopted by the City Council.*

Response: The site is located within the Frog Pond West neighborhood of the Frog Pond planning area. The Frog Pond West Master Plan has been incorporated into the Comprehensive Plan and designates the site for single-family residential development. Consistency with the Comprehensive Plan is addressed in Section III of this narrative. The RN zone is identified as the implementing zone for the Residential Neighborhood RN Comprehensive Plan designation; this zone requires that all development within it be approved as a Planned Development.

2. *That the location, design, size and uses are such that traffic generated by the development at the most probable used intersection(s) can be accommodated safely and without congestion in excess of Level of Service D, as defined in the Highway Capacity Manual published by the*

National Highway Research Board, on existing or immediately planned arterial or collector streets and will, in the case of commercial or industrial developments, avoid traversing local streets. Immediately planned arterial and collector streets are those listed in the City's adopted Capital Improvement Program, for which funding has been approved or committed, and that are scheduled for completion within two years of occupancy of the development or four year if they are an associated crossing, interchange, or approach street improvement to Interstate 5.

- a. In determining levels of Service D, the City shall hire a traffic engineer at the applicant's expense who shall prepare a written report containing the following minimum information for consideration by the Development Review Board:
 - i. An estimate of the amount of traffic generated by the proposed development, the likely routes of travel of the estimated generated traffic, and the source(s) of information of the estimate of the traffic generated and the likely routes of travel; [Added by Ord. 561, adopted 12/15/03.]
 - ii. What impact the estimate generated traffic will have on existing level of service including traffic generated by (1) the development itself, (2) all existing developments, (3) Stage II developments approved but not yet built, and (4) all developments that have vested traffic generation rights under section 4.140(.10), through the most probable used intersection(s), including state and county intersections, at the time of peak level of traffic. This analysis shall be conducted for each direction of travel if backup from other intersections will interfere with intersection operations. [Amended by Ord 561, adopted 12/15/03.]
- b. The following are exempt from meeting the Level of Service D criteria standard:
 - i. A planned development or expansion thereof which generates three (3) new p.m. peak hour traffic trips or less;
 - ii. A planned development or expansion thereof which provides an essential governmental service.
- c. Traffic generated by development exempted under this subsection on or after Ordinance No. 463 was enacted shall not be counted in determining levels of service for any future applicant. [Added by Ord 561, adopted 12/15/03.]
- d. Exemptions under 'b' of this subsection shall not exempt the development or expansion from payment of system development charges or other applicable regulations. [Added by Ord 561, adopted 12/15/03.]
- e. In no case will development be permitted that creates an aggregate level of traffic at LOS "F". [Added by Ord 561, adopted 12/15/03.]

Response: The City's Traffic Engineer, DKS Associates has determined that a full Traffic Impact Study (TIS) is necessary to evaluate traffic impacts from the proposed development. They have prepared a memo outlining the anticipated impacts. The memo is included in this proposal as Appendix C and addresses the provisions above.

3. That the location, design, size and uses are such that the residents or establishments to be accommodated will be adequately served by existing or immediately planned facilities and services.

Response: The proposal will construct transportation infrastructure with site development and will dedicate public right-of-way to Frog Pond Ln, Larkspur Terr (future), Willow Creek Dr (future), Marigold Terr (future), and Kahle Rd (future). The site will be adequately served.

[...]

(.10) Early Vesting of Traffic Generation. [...]

Response: No early vesting of traffic generation is requested. This standard is not applicable.

V. General Development Regulations

A. Section 4.154. On-site Pedestrian Access and Circulation.

(.01) On-site Pedestrian Access and Circulation

A. *The purpose of this section is to implement the pedestrian access and connectivity policies of the Transportation System Plan. It is intended to provide for safe, reasonably direct, and convenient pedestrian access and circulation.*

Response: Applicable standards include the Transportation System Plan as modified/amended by the Frog Pond West Master Plan.

B. *Standards. Development shall conform to all of the following standards:*

1. *Continuous Pathway System. A pedestrian pathway system shall extend throughout the development site and connect to adjacent sidewalks, and to all future phases of the development, as applicable.*
2. *Safe, Direct, and Convenient. Pathways within developments shall provide safe, reasonably direct, and convenient connections between primary building entrances and all adjacent parking areas, recreational areas/playgrounds, and public rights-of-way and crosswalks based on all of the following criteria:*
 - a. *Pedestrian pathways are designed primarily for pedestrian safety and convenience, meaning they are free from hazards and provide a reasonably smooth and consistent surface.*
 - b. *The pathway is reasonably direct. A pathway is reasonably direct when it follows a route between destinations that does not involve a significant amount of unnecessary out-of-direction travel.*
 - c. *The pathway connects to all primary building entrances and is consistent with the Americans with Disabilities Act (ADA) requirements.*
 - d. *All parking lots larger than three acres in size shall provide an internal bicycle and pedestrian pathway pursuant to Section 4.155(.03)(B.)(3.)(d.).*

Response: The site is a single-family residential development and includes a network of public sidewalks. In addition to the sidewalk system, pedestrian/bicycle connections are proposed through Tract E and connecting to proposed Street E and to future Khale Road and the Boeckman Creek Trail. The proposed sidewalk network, the pedestrian pathway in Tract E, and the alignment of this site with the pedestrian pathway to the east will provide continuous pedestrian connections to the Boeckman Creek Trail that extends east near Khale Road.

3. *Vehicle/Pathway Separation. Except as required for crosswalks, per subsection 4, below, where a pathway abuts a driveway or street it shall be vertically or horizontally separated from the vehicular lane. For example, a pathway may be vertically raised six inches above the abutting travel lane, or horizontally separated by a row of bollards.*

Response: The site includes a network of local streets with sidewalks that are separated from vehicle travel lanes. Specific pedestrian pathways are proposed in Tract E. This standard is met.

4. *Crosswalks. Where a pathway crosses a parking area or driveway, it shall be clearly marked with contrasting paint or paving materials (e.g., pavers, light-color concrete inlay between asphalt, or similar contrast).*

Response: The proposed pathways do not cross a parking area or driveway. Sidewalks will traverse through residential driveways meeting the design and material standards of the TSP. This standard is met.

5. *Pathway Width and Surface. Primary pathways shall be constructed of concrete, asphalt, brick/masonry pavers, or other durable surface, and not less than five (5) feet wide. Secondary pathways and pedestrian trails may have an alternative surface except as otherwise required by the ADA.*

Response: The proposed pedestrian pathways will be constructed of concrete, asphalt, brick/masonry pavers, or other durable surface, and will be at least 5 ft. wide. This standard is met.

6. *All pathways shall be clearly marked with appropriate standard signs.*
[Added by Ord. #719, 6/17/13]

Response: The pedestrian pathways will be signed as required.

B. Section 4.155. General Regulations - Parking, Loading and Bicycle Parking.

[...]

(.02) *General Provisions:*

- A. *The provision and maintenance of off-street parking spaces is a continuing obligation of the property owner. The standards set forth herein shall be considered by the Development Review Board as minimum criteria.*
 1. *The Board shall have the authority to grant variances or planned development waivers to these standards in keeping with the purposes and objectives set forth in the Comprehensive Plan and this Code.*
 2. *Waivers to the parking, loading, or bicycle parking standards shall only be issued upon a findings that the resulting development will have no significant adverse impact on the surrounding neighborhood, and the community, and that the development considered as a whole meets the purposes of this section.*
- B. *No area shall be considered a parking space unless it can be shown that the area is accessible and usable for that purpose, and has maneuvering area for the vehicles, as determined by the Planning Director.*
- C. *In cases of enlargement of a building or a change of use from that existing on the effective date of this Code, the number of parking spaces required shall be based on the additional floor area of the enlarged or additional building, or changed use, as set forth in this Section. Current development standards, including parking area landscaping and screening, shall apply only to the additional approved parking area.*
- D. *In the event several uses occupy a single structure or parcel of land, the total requirement for off-street parking shall be the sum of the requirements of the several uses computed separately, except as modified by subsection "E," below. Within the TC Zone, the cumulative number of parking spaces required by this subsection may be reduced by 25 percent. [Amended by Ord. 835, 6/5/19]*
- E. *Owners of two (2) or more uses, structures, or parcels of land may utilize jointly the same parking area when the peak hours of operation do not overlap, provided satisfactory legal evidence is presented in the form of deeds, leases, or contracts securing full and permanent access to such parking areas for all the parties jointly using them. [Amended by Ord. # 674 11/16/09]*
- F. *Off-street parking spaces existing prior to the effective date of this Code may be included in the amount necessary to meet the requirements in case of subsequent enlargement of the building or use to which such spaces are necessary.*
- G. *Off-Site Parking. Except for single-family dwellings, the vehicle parking spaces required by this Chapter may be located on another parcel of land, provided the parcel is within 500 feet of the use it serves and the DRB has approved the off-site parking through the Land Use Review. The distance from the parking area to the use shall be measured from the nearest parking space to the main building entrance, following a sidewalk or other pedestrian route. Within the TC Zone there is no maximum distance to an off-site location provided the off-site parking is located within the TC Zone. The right to use the off-site parking must be evidenced in the form of recorded deeds, easements, leases, or contracts securing full and permanent access to such parking areas for all the parties jointly using them. Within the TC zone, there is no maximum distance to an off-site location provided the off-site parking is located within the TC Zone. [Amended by Ord. 835, 6/5/19]*
- H. *The conducting of any business activity shall not be permitted on the required parking spaces unless a temporary use permit is approved pursuant to Section 4.163.*
- I. *Where the boundary of a parking lot adjoins or is within a residential district, such parking lot shall be screened by a sight-obscuring fence or planting. The screening shall be continuous along that boundary and shall be at least six (6) feet in height.*
- J. *Parking spaces along the boundaries of a parking lot shall be provided with a sturdy bumper guard or curb at least six (6) inches high and located far enough within the boundary to prevent any portion of a car within the lot from extending over the property line or interfering with required screening or sidewalks.*
- K. *All areas used for parking and maneuvering of cars shall be surfaced with asphalt, concrete, or other surface, such as pervious materials (i. e. pavers, concrete, asphalt) that is found by the City's authorized representative to be suitable for the purpose. In all cases, suitable drainage, meeting*

standards set by the City's authorized representative, shall be provided. [Amended by Ord. # 674 11/16/09]

- L. Artificial lighting which may be provided shall be so limited or deflected as not to shine into adjoining structures or into the eyes of passers-by.
- M. Off-street parking requirements for types of uses and structures not specifically listed in this Code shall be determined by the Development Review Board if an application is pending before the Board. Otherwise, the requirements shall be specified by the Planning Director, based upon consideration of comparable uses.
- N. Up to forty percent (40%) of the off-street spaces may be compact car spaces as identified in Section 4.001 - "Definitions," and shall be appropriately identified.
- O. Where off-street parking areas are designed for motor vehicles to overhang beyond curbs, planting areas adjacent to said curbs shall be increased to a minimum of seven (7) feet in depth. This standard shall apply to a double row of parking, the net effect of which shall be to create a planted area that is a minimum of seven (7) feet in depth.
- P. Parklets are permitted within the TC Zone on up to two parking spaces per block and shall be placed in front of the business. Placement of parklet requires a temporary right-of-way use permit and approval by the City Engineer. [Added by Ord. 835, 6/5/19]

Response: Generally, these provisions apply to multifamily and commercial development, which is not proposed within Frog Pond Oaks. These provisions are not applicable.

(.03) Minimum and Maximum Off-Street Parking Requirements:

- A. Parking and loading or delivery areas shall be designed with access and maneuvering area adequate to serve the functional needs of the site and shall:
 - 1. Separate loading and delivery areas and circulation from customer and/or employee parking and pedestrian areas. Circulation patterns shall be clearly marked.
 - 2. To the greatest extent possible, separate vehicle and pedestrian traffic.
- B. Parking and loading or delivery areas shall be landscaped to minimize the visual dominance of the parking or loading area, as follows: [...]

Response: There is no off-street loading required or proposed for the proposed single-family development. These provisions are not applicable.

- C. Off Street Parking shall be designed for safe and convenient access that meets ADA and ODOT standards. All parking areas which contain ten (10) or more parking spaces, shall for every fifty (50) standard spaces., provide one ADA-accessible parking space that is constructed to building code standards, Wilsonville Code 9.000.
- D. Where possible, parking areas shall be designed to connect with parking areas on adjacent sites so as to eliminate the necessity for any mode of travel of utilizing the public street for multiple accesses or cross movements. In addition, on-site parking shall be designed for efficient on-site circulation and parking.
- E. In all multi-family dwelling developments, there shall be sufficient areas established to provide for parking and storage of motorcycles, mopeds and bicycles. Such areas shall be clearly defined and reserved for the exclusive use of these vehicles.
- F. On-street parking spaces, directly adjoining the frontage of and on the same side of the street as the subject property, may be counted towards meeting the minimum off-street parking standards.

Response: There are no parking areas required or proposed for the proposed single-family development. The required parking is being provided on-site. On-street parking spaces are not requested to count toward the minimum standards.

- G. Tables 5 shall be used to determine the minimum and maximum parking standards for various land uses. The minimum number of required parking spaces shown on Tables 5 shall be determined by rounding to the nearest whole parking space. For example, a use containing 500 square feet, in an area where the standard is one space for each 400 square feet of floor area, is required to provide one off-street parking space. If the same use contained more than 600 square feet, a second parking space would be required. Structured parking and on-street parking are exempted from the parking maximums in Table 5. [Amended by Ordinance No. 538, 2/21/02.]

Response: Table 5 requires that single units provide one parking space per dwelling unit. There is no maximum number listed. Each single-family dwelling unit will be provided with at least two parking spaces within garages. This standard is met.

H. Electrical Vehicle Charging Stations:

1. *Parking spaces designed to accommodate and provide one or more electric vehicle charging stations on site may be counted towards meeting the minimum off-street parking standards.*
2. *Modification of existing parking spaces to accommodate electric vehicle charging stations on site is allowed outright.*

Response: No electrical vehicle charging stations are proposed at this time.

I. Motorcycle parking:

1. *Motorcycle parking may substitute for up to 5 spaces or 5 percent of required automobile parking, whichever is less. For every 4 motorcycle parking spaces provided, the automobile parking requirement is reduced by one space.*
2. *Each motorcycle space must be at least 4 feet wide and 8 feet deep. Existing parking may be converted to take advantage of this provision.*

[Amended by Ord. #719, 6/17/13]

Response: No motorcycle parking is proposed.

(.04) Bicycle Parking:

A. Required Bicycle Parking - General Provisions.

1. *The required minimum number of bicycle parking spaces for each use category is shown in Table 5, Parking Standards.[...]*

Response: Table 5 states that there is no minimum bicycle parking requirement for detached or attached single-family homes. These provisions are not applicable.

(.05) Minimum Off-Street Loading Requirements: [...]

Response: There is no off-street loading requirement for single-family homes. These provisions are not applicable.

(.06) Carpool and Vanpool Parking Requirements: [...]

Response: There is no carpool or vanpool parking requirement for single-family homes. These provisions are not applicable.

C. Section 4.156. Sign Code Regulations.

Section 4.156.07. Sign Regulations In Residential Zones.

[...]

Response: No signs are proposed at this time. Future signs will be subject to these regulations.

D. Section 4.167. General Regulations - Access, Ingress and Egress.

(.01) Each access onto streets or private drives shall be at defined points as approved by the City and shall be consistent with the public's health, safety and general welfare. Such defined points of access shall be approved at the time of issuance of a building permit if not previously determined in the development permit. [Amended by Ord. 682, 9/9/10]

Response: Proposed driveway access onto streets and private drives is shown in Sheet P2.00.

E. Section 4.169. General Regulations – Double-Frontage Lots.

(.01) Buildings on double frontage lots (i.e., through lots) and corner lots must meet the front yard setback for principal buildings on both streets or tracts with a private drive. [Amended by Ord. 682,

9/9/10]

(.02) *Given that double-frontage lots tend to have one end that is regarded as a rear yard by the owner, the Development Review Board may establish special maintenance conditions to apply to such areas. Such conditions may include the requirement that the subject homeowners association, if any, be responsible for the on-going maintenance of the street frontage areas of double-frontage lots.*

Response: There are no double-frontage lots proposed in this development. These provisions are not applicable

F. Section 4.171. General Regulations - Protection of Natural Features and Other Resources.

(.02) General Terrain Preparation:

- A. *All developments shall be planned, designed, constructed and maintained with maximum regard to natural terrain features and topography, especially hillside areas, floodplains, and other significant landforms.*
- B. *All grading, filling and excavating done in connection with any development shall be in accordance with the Uniform Building Code*
- C. *In addition to any permits required under the Uniform Building Code, all developments shall be planned, designed, constructed and maintained so as to:*
 - 1. *Limit the extent of disturbance of soils and site by grading, excavation and other land alterations.*
 - 2. *Avoid substantial probabilities of: (1) accelerated erosion; (2) pollution, contamination, or siltation of lakes, rivers, streams and wetlands; (3) damage to vegetation; (4) injury to wildlife and fish habitats.*
 - 3. *Minimize the removal of trees and other native vegetation that stabilize hillsides, retain moisture, reduce erosion, siltation and nutrient runoff, and preserve the natural scenic character.*

Response: The development has been planned and designed to avoid the natural features on the site, including a tree grove in the northwest portion of the property, and several mature trees on the site's eastern boundary. Grading, filling, and excavating will be conducted in accordance with the Uniform Building Code. The site will be protected with erosion control measures and trees to be preserved on site will be staked prior to commencement of site work to avoid damage to vegetation or injury to habitat. The removal of trees is necessary for site development, but replacement trees will be planted per the provisions of this code.

(.03) Hillsides: *All developments proposed on slopes greater than 25% shall be limited to the extent that: [...]*

Response: No slopes greater than 25 percent are present on the site.

(.04) Trees and Wooded Areas.

- A. *All developments shall be planned, designed, constructed and maintained so that:*
 - 1. *Existing vegetation is not disturbed, injured, or removed prior to site development and prior to an approved plan for circulation, parking and structure location.*
 - 2. *Existing wooded areas, significant clumps/groves of trees and vegetation, and all trees with a diameter at breast height of six inches or greater shall be incorporated into the development plan and protected wherever feasible.*
 - 3. *Existing trees are preserved within any right-of-way when such trees are suitably located, healthy, and when approved grading allows.*
- B. *Trees and woodland areas to be retained shall be protected during site preparation and construction according to City Public Works design specifications, by:*
 - 1. *Avoiding disturbance of the roots by grading and/or compacting activity.*
 - 2. *Providing for drainage and water and air filtration to the roots of trees which will be covered with impermeable surfaces.*
 - 3. *Requiring, if necessary, the advisory expertise of a registered arborist/horticulturist both during and after site preparation.*
 - 4. *Requiring, if necessary, a special maintenance, management program to insure survival of specific woodland areas of specimen trees or individual heritage status trees.*

Response: Existing vegetation will not be disturbed, injured or removed prior to land use and permit approvals. Existing trees have been retained wherever possible; however, 38 trees are proposed to be removed to provide area for home construction and site work. The existing grove of mature, native trees in the northwest area of the site and those along the eastern boundary have been prioritized for protection and have been incorporated into open space.

(.05) High Voltage Powerline Easements and Rights of Way and Petroleum Pipeline Easements:

- A. *Due to the restrictions placed on these lands, no residential structures shall be allowed within high voltage powerline easements and rights of way and petroleum pipeline easements, and any development, particularly residential, adjacent to high voltage powerline easements and rights of way and petroleum pipeline easements shall be carefully reviewed.*
- B. *Any proposed non-residential development within high voltage powerline easements and rights of way and petroleum pipeline easements shall be coordinated with and approved by the Bonneville Power Administration, Portland General Electric Company or other appropriate utility, depending on the easement or right of way ownership.*

Response: No high voltage powerline easements or petroleum pipeline easements are present on site. There is a BPA easement in the far northeast corner of the subject property. BPA has indicated via direct communication that no LUA is required for dedicating right-of-way or planting and seeding this area. LUA will be required up the development of Kahle road. See communications from the BPA submitted with this application as Appendix K.

(.06) Hazards to Safety: Purpose:

- A. *To protect lives and property from natural or human-induced geologic or hydrologic hazards and disasters.*
- B. *To protect lives and property from damage due to soil hazards.*
- C. *To protect lives and property from forest and brush fires.*
- D. *To avoid financial loss resulting from development in hazard areas.*

Response: No hydrologic, soil, fire, or other hazards have been identified on site.

(.07) Standards for Earth Movement Hazard Areas:

- A. *No development or grading shall be allowed in areas of land movement, slump or earth flow, and mud or debris flow, except under one of the following conditions:*
 - 1. *Stabilization of the identified hazardous condition based on established and proven engineering techniques which ensure protection of public and private property. Appropriate conditions of approval may be attached by the City.*
 - 2. *An engineering geologic study approved by the City establishing that the site is stable for the proposed use and development. The study shall include the following:*
 - a. *Index map.*
 - b. *Project description, to include: location; topography, drainage, vegetation; discussion of previous work; and discussion of field exploration methods.*
 - c. *Site geology, to include: site geologic map; description of bedrock and superficial materials including artificial fill; location of any faults, folds, etc.; and structural data including bedding, jointing, and shear zones.*
 - d. *Discussion and analysis of any slope stability problems.*
 - e. *Discussion of any off-site geologic conditions that may pose a potential hazard to the site or that may be affected by on-site development.*
 - f. *Suitability of site for proposed development from geologic standpoint.*
 - g. *Specific recommendations for cut slope stability, seepage and drainage control, or other design criteria to mitigate geologic hazards.*
 - h. *Supportive data, to include: cross sections showing subsurface structure; graphic logs of subsurface explorations; results of laboratory tests; and references.*
 - i. *Signature and certification number of engineering geologist registered in the State of Oregon.*
 - j. *Additional information or analyses as necessary to evaluate the site.*
- B. *Vegetative cover shall be maintained or established for stability and erosion control purposes.*
- C. *Diversion of storm water into these areas shall be prohibited.*
- D. *The principal source of information for determining earth movement hazards is the State Department of Geology and Mineral Industries (DOGAMI) Bulletin 99 and any subsequent bulletins and accompanying maps. Approved site specific engineering geologic studies shall be used to identify*

the extent and severity of the hazardous conditions on the site, and to update the earth movement hazards database.

Response: Geotechnical investigations have been completed for the subject property, and no earth movement hazards have been identified. See Appendix F for geotechnical reports.

(.08) Standards for Soil Hazard Areas:

- A. *Appropriate siting and design safeguards shall insure structural stability and proper drainage of foundation and crawl space areas for development on land with any of the following soil conditions: wet or high water table; high shrink-swell capability; compressible or organic; and shallow depth-to-bedrock.*
- B. *The principal source of information for determining soil hazards is the State DOGAMI Bulletin 99 and any subsequent bulletins and accompanying maps. Approved site-specific soil studies shall be used to identify the extent and severity of the hazardous conditions on the site, and to update the soil hazards database accordingly.*

Response: Geotechnical investigations have been completed for the subject property, and no soil hazard areas have been identified. See Appendix F for geotechnical reports.

(.09) Historic Protection: Purpose:

- A. *To preserve structures, sites, objects, and areas within the City of Wilsonville having historic, cultural, or archaeological significance.*

Response: No historic, cultural, or archaeological items have been identified on the site.

G. Section 4.175. Public Safety and Crime Prevention.

- (.01) All developments shall be designed to deter crime and insure public safety.*
- (.02) Addressing and directional signing shall be designed to assure identification of all buildings and structures by emergency response personnel, as well as the general public.*
- (.03) Areas vulnerable to crime shall be designed to allow surveillance. Parking and loading areas shall be designed for access by police in the course of routine patrol duties.*
- (.04) Exterior lighting shall be designed and oriented to discourage crime.*

Response: The Frog Pond Oaks development has been designed to deter crime and ensure public safety. As shown on Sheet IL-4, streets and pedestrian connections will be lit for visibility and safety. Homes will be oriented toward these streets to provide “eyes on the street.” All dwellings will be addressed per Building and Fire Department requirements to allow identification for emergency response personnel. No parking and loading areas are proposed. Dwellings will have exterior porch lighting, which will support the streetlights to provide safety and visibility. These standards are met.

H. Section 4.176. Landscaping, Screening, and Buffering.

[...]

(.02) Landscaping and Screening Standards.

[...]

C. General Landscaping Standard.

[...]

- 2. *Required materials. Shrubs and trees, other than street trees, may be grouped. Ground cover plants must fully cover the remainder of the landscaped area (see Figure 21: General Landscaping). The General Landscaping Standard has two different requirements for trees and shrubs:*
 - a. *Where the landscaped area is less than 30 feet deep, one tree is required for every 30 linear feet.*
 - b. *Where the landscaped area is 30 feet deep or greater, one tree is required for every 800 square feet and two high shrubs or three low shrubs are required for every 400 square feet.*

Response: The proposed development consists of single-family dwellings, which are generally subject to the General Landscape Standard. The landscape plan included as Sheets L2.00-L2.40 illustrate the location and type of landscaping within public rights-of-way and tracts.

D. Low Screen Landscaping Standard.

1. *Intent. The Low Screen Landscaping Standard is a landscape treatment that uses a combination of distance and low screening to separate uses or developments. It is intended to be applied in situations where low screening is adequate to soften the impact of one use or development on another, or where visibility between areas is more important than a total visual screen. The Low Screen Landscaping Standard is usually applied along street lot lines or in the area separating parking lots from street rights-of-way.*
2. *Required materials. The Low Screen Landscaping Standard requires sufficient low shrubs to form a continuous screen three (3) feet high and 95% opaque, year-round. In addition, one tree is required for every 30 linear feet of landscaped area, or as otherwise required to provide a tree canopy over the landscaped area. Ground cover plants must fully cover the remainder of the landscaped area. A three (3) foot high masonry wall or a berm may be substituted for the shrubs, but the trees and ground cover plants are still required. When applied along street lot lines, the screen or wall is to be placed along the interior side of the landscaped area. (See Figure 22: Low Screen Landscaping).*

Response: The proposed development consists of single-family dwellings, which are generally subject to the General Landscape Standard. The landscape plan included as Sheets L2.00-L2.40 illustrate the location and type of landscaping within public rights-of-way and tracts.

E. High Screen Landscaping Standard.

1. *Intent. The High Screen Landscaping Standard is a landscape treatment that relies primarily on screening to separate uses or developments. It is intended to be applied in situations where visual separation is required.*
2. *Required materials. The High Screen Landscaping Standard requires sufficient high shrubs to form a continuous screen at least six (6) feet high and 95% opaque, year-round. In addition, one tree is required for every 30 linear feet of landscaped area, or as otherwise required to provide a tree canopy over the landscaped area. Ground cover plants must fully cover the remainder of the landscaped area. A six (6) foot high masonry wall or a berm may be substituted for the shrubs, but the trees and ground cover plants are still required. When applied along street lot lines, the screen or wall is to be placed along the interior side of the landscaped area. (See Figure 23: High Screen Landscaping).*

Response: The proposed residential development is located adjacent to future residential development. No screening is required or provided between uses.

F. High Wall Standard.

1. *Intent. The High Wall Standard is intended to be applied in situations where extensive screening to reduce both visual and noise impacts is needed to protect abutting uses or developments from one-another. This screening is most important where either, or both, of the abutting uses or developments can be expected to be particularly sensitive to noise or visual impacts, or where there is little space for physical separation.*
2. *Required materials. The High Wall Standard requires a masonry wall at least six (6) feet high along the interior side of the landscaped area (see Figure 24: High Wall Landscaping). In addition, one tree is required for every 30 linear feet of wall, or as otherwise required to provide a tree canopy over the landscaped area. Ground cover plants must fully cover the remainder of the landscaped area.*

Response: There are no visual or noise impacts anticipated from the proposed development, and high walls are not required or proposed.

G. High Berm Standard.

1. *Intent. The High Berm Standard is intended to be applied in situations where extensive screening to reduce both visual and noise impacts is needed to protect abutting uses or developments from one-another, and where it is desirable and practical to provide separation by both distance and sight-obscuring materials. This screening is most important where either, or both, of the abutting uses or developments can be expected to be particularly sensitive to noise or visual impacts.*
2. *Required materials. The High Berm Standard requires a berm at least four (4) feet high along the interior side of the landscaped area (see Figure 25: High Berm Landscaping). If the berm is less*

than six (6) feet high, low shrubs meeting the Low Screen Landscaping Standard, above, are to be planted along the top of the berm, assuring that the screen is at least six (6) feet in height. In addition, one tree is required for every 30 linear feet of berm, or as otherwise required to provide a tree canopy over the landscaped area. Ground cover plants must fully cover the remainder of the landscaped area.

Response: There are no visual or noise impacts anticipated from the proposed development, and a high berm is not required or provided.

H. Partially Sight-Obscuring Fence Standard.

1. *Intent. The Partially Sight-Obscuring Fence Standard is intended to provide a tall, but not totally blocked, visual separation. The standard is applied where a low level of screening is adequate to soften the impact of one use or development on another, and where some visibility between abutting areas is preferred over a total visual screen. It can be applied in conjunction with landscape plantings or applied in areas where landscape plantings are not necessary and where nonresidential uses are involved.*
2. *Required materials. Partially Sight-Obscuring Fence Standard are to be at least six (6) feet high and at least 50% sight-obscuring. Fences may be made of wood (other than plywood or particle-board), metal, bricks, masonry or other permanent materials (see Figure 26: Partially Sight-Obscuring Fence).*

I. Fully Sight-Obscuring Fence Standard.

1. *Intent. The Fully Sight-Obscuring Fence Standard is intended to provide a totally blocked visual separation. The standard is applied where full visual screening is needed to reduce the impact of one use or development on another. It can be applied in conjunction with landscape plantings or applied in areas where landscape plantings are not necessary.*
2. *Required materials. Fully sight-obscuring fences are to be at least six (6) feet high and 100% sight-obscuring. Fences may be made of wood (other than plywood or particle-board), metal, bricks, masonry or other permanent materials (see Figure 27: Totally Sight-Obscuring Fence).*

Response: There is no need for partially or totally blocked visual separation. Sight-obscuring fencing is not provided.

(.03) Landscape Area. *Not less than fifteen percent (15%) of the total lot area, shall be landscaped with vegetative plant materials. The ten percent (10%) parking area landscaping required by section 4.155.03(B)(1) is included in the fifteen percent (15%) total lot landscaping requirement. Landscaping shall be located in at least three separate and distinct areas of the lot, one of which must be in the contiguous frontage area. Planting areas shall be encouraged adjacent to structures. Landscaping shall be used to define, soften or screen the appearance of buildings and off-street parking areas. Materials to be installed shall achieve a balance between various plant forms, textures, and heights. The installation of native plant materials shall be used whenever practicable. (For recommendations refer to the Native Plant List maintained by the City of Wilsonville). [Amended by Ord. # 674 11/16/09]*

Response: At least 15 percent of the total lot area for each single-family dwelling will be landscaped; conformance with this standard will be reviewed at the time of building permit submittal. There are no parking areas proposed and no parking area landscaping is required. The landscape plan included as Sheets L2.00-L2.40 illustrate the location and type of landscaping within public rights-of-way and tracts.

(.04) Buffering and Screening. *Additional to the standards of this subsection, the requirements of the Section 4.137.5 (Screening and Buffering Overlay Zone) shall also be applied, where applicable.*

- A. *All intensive or higher density developments shall be screened and buffered from less intense or lower density developments.*
- B. *Activity areas on commercial and industrial sites shall be buffered and screened from adjacent residential areas. Multi-family developments shall be screened and buffered from single-family areas.*
- C. *All exterior, roof and ground mounted, mechanical and utility equipment shall be screened from ground level off-site view from adjacent streets or properties.*
- D. *All outdoor storage areas shall be screened from public view unless visible storage has been approved for the site by the Development Review Board or Planning Director acting on a development permit.*
- E. *In all cases other than for industrial uses in industrial zones, landscaping shall be designed to screen loading areas and docks, and truck parking.*

- F. In any zone any fence over six (6) feet high measured from soil surface at the outside of fence line shall require Development Review Board approval.

Response: The requirements of 4.137.5 are applicable along the edge of nonresidential zones abutting, or located directly across the street from, residential zones. The proposed development is located within a residential zone and is anticipated to abut residential development in accordance with the Frog Pond Master Plan. These provisions are not applicable.

(.05) Sight-Obscuring Fence or Planting. *The use for which a sight-obscuring fence or planting is required shall not begin operation until the fence or planting is erected or in place and approved by the City. A temporary occupancy permit may be issued upon a posting of a bond or other security equal to one hundred ten percent (110%) of the cost of such fence or planting and its installation. (See Sections 4.400 to 4.470 for additional requirements.)*

Response: No sight-obscuring fences or planting are required between the proposed residential use and adjacent uses. This standard is not applicable.

(.06) Plant Materials.

A. *Shrubs and Ground Cover. All required ground cover plants and shrubs must be of sufficient size and number to meet these standards within three (3) years of planting. Non-horticultural plastic sheeting or other impermeable surface shall not be placed under mulch. Native topsoil shall be preserved and reused to the extent feasible. Surface mulch or bark dust are to be fully raked into soil of appropriate depth, sufficient to control erosion, and are confined to areas around plantings. Areas exhibiting only surface mulch, compost or bark dust are not to be used as substitutes for plant areas. [Amended by Ord. # 674 11/16/09]*

1. *Shrubs. All shrubs shall be well branched and typical of their type as described in current AAN Standards and shall be equal to or better than 2-gallon containers and 10" to 12" spread.*
2. *Ground cover. Shall be equal to or better than the following depending on the type of plant materials used: gallon containers spaced at 4 feet on center minimum, 4" pot spaced 2 feet on center minimum, 2-1/4" pots spaced at 18 inch on center minimum. No bare root planting shall be permitted. Ground cover shall be sufficient to cover at least 80% of the bare soil in required landscape areas within three (3) years of planting. Where wildflower seeds are designated for use as a ground cover, the City may require annual re-seeding as necessary.*
3. *Turf or lawn in non-residential developments. Shall not be used to cover more than ten percent (10%) of the landscaped area, unless specifically approved based on a finding that, due to site conditions and availability of water, a larger percentage of turf or lawn area is appropriate. Use of lawn fertilizer shall be discouraged. Irrigation drainage runoff from lawns shall be retained within lawn areas.*
4. *Plant materials under trees or large shrubs. Appropriate plant materials shall be installed beneath the canopies of trees and large shrubs to avoid the appearance of bare ground in those locations.*
5. *Integrate compost-amended topsoil in all areas to be landscaped, including lawns, to help detain runoff, reduce irrigation and fertilizer needs, and create a sustainable, low-maintenance landscape. [Added by Ord. # 674 11/16/09]*

Response: The landscape plan included as Sheets L2.00-L2.40 addresses these requirements.

- B. *Trees. All trees shall be well-branched and typical of their type as described in current American Association of Nurserymen (AAN) Standards and shall be balled and burlapped. The trees shall be grouped as follows:*
1. *Primary trees which define, outline or enclose major spaces, such as Oak, Maple, Linden, and Seedless Ash, shall be a minimum of 2" caliper.*
 2. *Secondary trees which define, outline or enclose interior areas, such as Columnar Red Maple, Flowering Pear, Flame Ash, and Honeylocust, shall be a minimum of 1-3/4" to 2" caliper.*
 3. *Accent trees which, are used to add color, variation and accent to architectural features, such as Flowering Pear and Kousa Dogwood, shall be 1-3/4" minimum caliper.*
 4. *Large conifer trees such as Douglas Fir or Deodar Cedar shall be installed at a minimum height of eight (8) feet.*
 5. *Medium-sized conifers such as Shore Pine, Western Red Cedar or Mountain Hemlock shall be installed at a minimum height of five to six (5 to 6) feet.*

Response: The landscape plan included as Sheets L2.00-L2.40 addresses these requirements.

- C. *Where a proposed development includes buildings larger than twenty-four (24) feet in height or greater than 50,000 square feet in footprint area, the Development Review Board may require larger or more mature plant materials:*
1. *At maturity, proposed trees shall be at least one-half the height of the building to which they are closest, and building walls longer than 50 feet shall require tree groups located no more than fifty (50) feet on center, to break up the length and height of the façade.*
 2. *Either fully branched deciduous or evergreen trees may be specified depending upon the desired results. Where solar access is to be preserved, only solar-friendly deciduous trees are to be used. Where year-round sight obscuring is the highest priority, evergreen trees are to be used.*
 3. *The following standards are to be applied:*
 - a. *Deciduous trees:*
 - i. *Minimum height of ten (10) feet; and*
 - ii. *Minimum trunk diameter (caliper) of 2 inches (measured at four and one-half [4 1/2] feet above grade).*
 - b. *Evergreen trees: Minimum height of twelve (12) feet.*

Response: Some of the proposed residential dwellings will exceed 24 ft. in height but will be far less than 50,000 sq. ft. in footprint area. Requirements for larger or more mature plant materials are not warranted.

- D. *Street Trees. In order to provide a diversity of species, the Development Review Board may require a mix of street trees throughout a development. Unless the Board waives the requirement for reasons supported by a finding in the record, different types of street trees shall be required for adjoining blocks in a development.*
1. *All trees shall be standard base grafted, well branched and typical of their type as described in current AAN Standards and shall be balled and burlapped (b&b). Street trees shall be planted at sizes in accordance with the following standards:*
 - a. *Arterial streets - 3" minimum caliper*
 - b. *Collector streets - 2" minimum caliper.*
 - c. *Local streets or residential private access drives - 1-3/4" minimum caliper. [Amended by Ord. 682, 9/9/10]*
 - d. *Accent or median tree -1-3/4" minimum caliper.*

Response: Willow Creek Drive and Frog Pond Lane are classified as Collector streets; the other streets within the development are classified as Local Streets. As shown in Sheet L2.00, 2-in. caliper balled and burlapped street trees are proposed for all streets within the development, which are larger than required. Sheet L2.00 shows additional street trees added after staff's first review. Trees along the west side of (future) Marigold Terr will be planted when the street is developed. A street tree has been added to the planter between Lots 8 and 9.

2. *The following trees and varieties thereof are considered satisfactory street trees in most circumstances; however, other varieties and species are encouraged and will be considered:*
 - a. *Trees over 50 feet mature height: Quercus garryana (Native Oregon White Oak), Quercus rubra borealis (Red Oak), Acer Macrophyllum (Native Big Leaf Maple), Acer nigrum (Green Column Black Maple), Fraxinus americanus (White Ash), Fraxinus pennsylvannica 'Marshall' (Marshall Seedless Green Ash), Quercus coccinea (Scarlet Oak), Quercus pulustris (Pin Oak), Tilia americana (American Linden).*
 - b. *Trees under 50 feet mature height: Acer rubrum (Red Sunset Maple), Cornus nuttallii (Native Pacific Dogwood), Gleditsia triacanthos (Honey Locust), Pyrus calleryana 'Bradford' (Bradford Pear), Tilia cordata (Little Leaf Linden), Fraxinus oxycarpa (Flame Ash).*
 - c. *Other street tree species. Other species may be specified for use in certain situations. For instance, evergreen species may be specified where year-round color is desirable and no adverse effect on solar access is anticipated. Water-loving species may be specified in low locations where wet soil conditions are anticipated.*

[Section 4.176(.06)(D.) amended by Ordinance No. 538, 2/21/02.]

Response: The proposed street trees include a mix of Ulmus X 'Morton Accolade' TM/ELM, Gleditsia triacanthos inermis 'Skycole' (Skyline Thornless Honey Locust), pistacia chinensis 'Chinese Pistach,'

Quercus rubra (Red Oak). All trees listed here have been chosen from the approved street tree list for the Frog Pond West Master Plan, and they have been selected for the qualities that cause them to be frequently specified as street trees: predictable form, disease resistance, tidiness, and visual interest.

E. Types of Plant Species.

1. Existing landscaping or native vegetation may be used to meet these standards, if protected and maintained during the construction phase of the development and if the plant species do not include any that have been listed by the City as prohibited. The existing native and non-native vegetation to be incorporated into the landscaping shall be identified.
2. Selection of plant materials. Landscape materials shall be selected and sited to produce hardy and drought-tolerant landscaping. Selection shall be based on soil characteristics, maintenance requirements, exposure to sun and wind, slope and contours of the site, and compatibility with other vegetation that will remain on the site. Suggested species lists for street trees, shrubs and groundcovers shall be provided by the City of Wilsonville.
3. Prohibited plant materials. The City may establish a list of plants that are prohibited in landscaped areas. Plants may be prohibited because they are potentially damaging to sidewalks, roads, underground utilities, drainage improvements, or foundations, or because they are known to be invasive to native vegetation.
[Section 4.176(.06)(E.) amended by Ordinance No. 538, 2/21/02.]

Response: As shown on Sheets L2.00 – L2.40, the proposed landscape materials include a mix of native trees, shrubs, and groundcovers. No prohibited plant materials are proposed.

F. Tree Credit.

Existing trees that are in good health as certified by an arborist and are not disturbed during construction may count for landscaping tree credit as follows (measured at four and one-half feet above grade and rounded to the nearest inch):

Existing trunk diameter	Number of Tree Credits
18 to 24 inches in diameter	3 tree credits
25 to 31 inches in diameter	4 tree credits
32 inches or greater	5 tree credits

[Amended by Ord. # 674 11/16/09]

1. It shall be the responsibility of the owner to use reasonable care to maintain preserved trees. Trees preserved under this section may only be removed if an application for removal permit under Section 4.610.10(01)(H) has been approved. Required mitigation for removal shall be replacement with the number of trees credited to the preserved and removed tree.
2. Within five years of occupancy and upon notice from the City, the property owner shall replace any preserved tree that cannot be maintained due to disease or damage, or hazard or nuisance as defined in Chapter 6 of this code. The notice shall be based on complete information provided by an arborist. Replacement with the number of trees credited shall occur within one (1) growing season of notice.

Response: As shown on Sheet L1.00 and described in Appendix E, there are 104 trees on the site; 38 trees are proposed for removal, and 76 are to be preserved. Per the calculations above and shown in Table 5 below, 147 tree credits are provided by protected trees.

Table 5: Tree Credits

Count	Tag #	Diameter (inches)	Number of Tree Credits
1	59245	62	5
2	59294	52	5
3	59403	52	5
4	59376	48	5
5	59306	45	5
6	59282	38	5
7	59283	38	5
8	59351	38	5
9	59402	38	5
10	59297	36	5
11	59302	35	5
12	59287	34	5
13	59377	34	5
14	59386	34	5
15	59400	34	5
16	59314	32	5
17	59300	29	4
18	59288	28	4
19	59289	28	4
20	59378	28	4
21	59350	26	4
22	59284	25	4
23	59286	25	4
24	59341	24	3
25	59383	23	3
26	59298	22	3
27	59345	22	3
28	59353	22	3
29	59310	20	3
30	59311	20	3
31	59347	20	3
32	59389	20	3
33	59407	20	3
34	59285	19	3
35	59292	19	3
36	59345	18	3
Total		147	

(.07) Installation and Maintenance.

- A. *Installation. Plant materials shall be installed to current industry standards and shall be properly staked to assure survival. Support devices (guy wires, etc.) shall not be allowed to interfere with normal pedestrian or vehicular movement.*
- B. *Maintenance. Maintenance of landscaped areas is the on-going responsibility of the property owner. Any landscaping installed to meet the requirements of this Code, or any condition of approval established by a City decision-making body acting on an application, shall be continuously maintained in a healthy, vital and acceptable manner. Plants that die are to be replaced in kind, within one growing season, unless appropriate substitute species are approved by the City. Failure to maintain landscaping as required in this Section shall constitute a violation of this Code for which appropriate legal remedies, including the revocation of any applicable land development permits, may result.*
- C. *Irrigation. The intent of this standard is to assure that plants will survive the critical establishment period when they are most vulnerable due to a lack of watering and also to assure that water is not wasted through unnecessary or inefficient irrigation. Approved irrigation system plans shall specify one of the following:*
 - 1. *A permanent, built-in, irrigation system with an automatic controller. Either a spray or drip irrigation system, or a combination of the two, may be specified.*
 - 2. *A permanent or temporary system designed by a landscape architect licensed to practice in the State of Oregon, sufficient to assure that the plants will become established and drought-tolerant.*
 - 3. *Other irrigation system specified by a licensed professional in the field of landscape architecture or irrigation system design.*
 - 4. *A temporary permit issued for a period of one year, after which an inspection shall be conducted to assure that the plants have become established. Any plants that have died, or that appear to the Planning Director to not be thriving, shall be appropriately replaced within one growing season. An inspection fee and a maintenance bond or other security sufficient to cover all costs of replacing the plant materials shall be provided, to the satisfaction of the Community Development Director. Additionally, the applicant shall provide the City with a written license or easement to enter the property and cause any failing plant materials to be replaced.*
- D. *Protection. All required landscape areas, including all trees and shrubs, shall be protected from potential damage by conflicting uses or activities including vehicle parking and the storage of materials.*

Response: As detailed on Sheet L2.00, all landscape areas will be watered by a fully automatic underground irrigation system. These standards are met.

(.08) Landscaping on Corner Lots. *All landscaping on corner lots shall meet the vision clearance standards of Section 4.177. If high screening would ordinarily be required by this Code, low screening shall be substituted within vision clearance areas. Taller screening may be required outside of the vision clearance area to mitigate for the reduced height within it.*

Response: High screening is not required on any corner lots and is not proposed. This standard is not applicable.

(.09) Landscape Plans. *Landscape plans shall be submitted showing all existing and proposed landscape areas. Plans must be drawn to scale and show the type, installation size, number and placement of materials. Plans shall include a plant material list. Plants are to be identified by both their scientific and common names. The condition of any existing plants and the proposed method of irrigation are also to be indicated. Landscape plans shall divide all landscape areas into the following categories based on projected water consumption for irrigation:*

- A. *High water usage areas (+/- two (2) inches per week): small convoluted lawns, lawns under existing trees, annual and perennial flower beds, and temperamental shrubs;*
- B. *Moderate water usage areas (+/- one (1) inch per week): large lawn areas, average water-using shrubs, and trees;*
- C. *Low water usage areas (Less than one (1) inch per week, or gallons per hour): seeded fieldgrass, swales, native plantings, drought-tolerant shrubs, and ornamental grasses or drip irrigated areas.*
- D. *Interim or unique water usage areas: areas with temporary seeding, aquatic plants, erosion control areas, areas with temporary irrigation systems, and areas with special water-saving features or water harvesting irrigation capabilities. These categories shall be noted in general on the plan and on the plant material list.*

Response: A landscape plan is included as Sheets L2.00-L2.40 and water consumption categories are included with each of the plant lists, and each of the street trees. The proposed site development plan includes street tree and mitigation plantings, which consist of native vegetation that requires low water usage. Individual lot landscaping will be proposed at the time of building permit submittal and will likely include grass and ground coverings. These standards are met.

(.10) Completion of Landscaping. *The installation of plant materials may be deferred for a period of time specified by the Board or Planning Director acting on an application, in order to avoid hot summer or cold winter periods, or in response to water shortages. In these cases, a temporary permit shall be issued, following the same procedures specified in subsection (.07)(C)(3), above, regarding temporary irrigation systems. No final Certificate of Occupancy shall be granted until an adequate bond or other security is posted for the completion of the landscaping, and the City is given written authorization to enter the property and install the required landscaping, in the event that the required landscaping has not been installed. The form of such written authorization shall be submitted to the City Attorney for review.*

Response: Acknowledged. No deferral is requested at this time but may be requested in the future subject to the scenarios above.

(.11) Street Trees Not Typically Part of Site Landscaping. *Street trees are not subject to the requirements of this Section and are not counted toward the required standards of this Section. Except, however, that the Development Review Board may, by granting a waiver or variance, allow for special landscaping within the right-of-way to compensate for a lack of appropriate on-site locations for landscaping. See subsection (.06), above, regarding street trees.*

Response: No waiver or variance for on-site landscaping is requested. This standard is not applicable.

(.12) Mitigation and Restoration Plantings. *A mitigation plan is to be approved by the City's Development Review Board before the destruction, damage, or removal of any existing native plants. Plantings intended to mitigate the loss of native vegetation are subject to the following standards. Where these standards conflict with other requirements of this Code, the standards of this Section shall take precedence. The desired effect of this section is to preserve existing native vegetation.*

- A. *Plant Sources. Plant materials are to be native and are subject to approval by the City. They are to be non-clonal in origin; seed source is to be as local as possible, and plants must be nursery propagated or taken from a pre-approved transplantation area. All of these requirements are to be addressed in any proposed mitigation plan.*
- B. *Plant Materials. The mitigation plan shall specify the types and installation sizes of plant materials to be used for restoration. Practices such as the use of pesticides, fungicides, and fertilizers shall not be employed in mitigation areas unless specifically authorized and approved.*
- C. *Installation. Install native plants in suitable soil conditions. Plant materials are to be supported only when necessary because of extreme winds at the site. Where support is necessary, all stakes, guy wires or other measures are to be removed as soon as the plants can support themselves. Protect from animal and fowl predation and foraging until establishment.*
- D. *Irrigation. Permanent irrigation systems are generally not appropriate in restoration situations, and manual or temporary watering of new plantings is often necessary. The mitigation plan shall specify the method and frequency of manual watering, including any that may be necessary after the first growing season.*
- E. *Monitoring and Reporting. Monitoring of native landscape areas is the on-going responsibility of the property owner. Plants that die are to be replaced in kind and quantity within one year. Written proof of the survival of all plants shall be required to be submitted to the City's Planning Department one year after the planting is completed.*

[Section 4.176 amended by Ordinance No. 536, 1/7/02]

Response: The site is currently in residential and agricultural use, and site plantings consist primarily of grass and clustered trees. The existing grass and 38 trees will be removed for site development, specifically to accommodate the planned street network and desired lotting pattern. Tree removal will be mitigated as detailed in the response to Section 4.610.40. These standards are not applicable.

I. Section 4.177. Street Improvement Standards.

This section contains the City's requirements and standards for pedestrian, bicycle, and transit facility improvements to public streets, or within public easements. The purpose of this section is to ensure that development, including redevelopment, provides transportation facilities that are safe, convenient, and adequate in rough proportion to their impacts.

(.01) Development and related public facility improvements shall comply with the standards in this section, the Wilsonville Public Works Standards, and the Transportation System Plan, in rough proportion to the potential impacts of the development. Such improvements shall be constructed at the time of development or as provided by Section 4.140, except as modified or waived by the City Engineer for reasons of safety or traffic operations.

Response: The proposed public facility improvements are designed to be in substantial conformance with the standards in this section, the Wilsonville Public Works Standards, and the Transportation System Plan as modified by the Frog Pond Master Plan.

(.02) Street Design Standards.

A. *All street improvements and intersections shall provide for the continuation of streets through specific developments to adjoining properties or subdivisions.*

1. *Development shall be required to provide existing or future connections to adjacent sites through the use of access easements where applicable. Such easements shall be required in addition to required public street dedications as required in Section 4.236(.04).*

Response: The street network has been designed to be substantially consistent with the Frog Pond West Street Demonstration Plan with minor modifications due to the presence of a mature, native tree grove in the northwest portion of the property, and practical stormwater facility locations in Tracts A and B. Future connections to adjacent sites are anticipated to the west and east. This standard is met.

B. *The City Engineer shall make the final determination regarding right-of-way and street element widths using the ranges provided in Chapter 3 of the Transportation System Plan and the additional street design standards in the Public Works Standards.*

Response: No modifications to the proposed rights-of-way and street elements widths are proposed at this time. The development will construct the local street network in accordance with applicable standards. Frog Pond Lane and Willow Creek Drive will meet width and street element standards. See Sheet P2.10.

C. *Rights-of-way.*

1. *Prior to issuance of a Certificate of Occupancy Building permits or as a part of the recordation of a final plat, the City shall require dedication of rights-of-way in accordance with the Transportation System Plan. All dedications shall be recorded with the County Assessor's Office.*
2. *The City shall also require a waiver of remonstrance against formation of a local improvement district, and all non-remonstrances shall be recorded in the County Recorder's Office as well as the City's Lien Docket, prior to issuance of a Certificate of Occupancy Building Permit or as a part of the recordation of a final plat.*
3. *In order to allow for potential future widening, a special setback requirement shall be maintained adjacent to all arterial streets. The minimum setback shall be 55 feet from the centerline or 25 feet from the right-of-way designated on the Master Plan, whichever is greater.*

Response: This proposal includes the following right-of-way dedications as shown in Sheet P2.10:

- ROW dedication of 21.5 feet along the site's frontage with SW Frog Pond Lane
- ROW dedication of 7 feet along the site's frontage with (future) SW Marigold Terrace
- ROW dedication of 42.7 feet along the site's frontage with SW Willow Creek Drive
- ROW dedication of 10 feet for (future) SW Kahle Road

The site does not have frontage on an arterial street; therefore, the special setback does not apply. These standards are met.

D. *Dead-end Streets. New dead-end streets or cul-de-sacs shall not exceed 200 feet in length, unless the adjoining land contains barriers such as existing buildings, railroads or freeways, or environmental*

constraints such as steep slopes, or major streams or rivers, that prevent future street extension and connection. A central landscaped island with rainwater management and infiltration are encouraged in cul-de-sac design. No more than 25 dwelling units shall take access to a new dead-end or cul-de-sac street unless it is determined that the traffic impacts on adjacent streets will not exceed those from a development of 25 or fewer units. All other dimensional standards of dead-end streets shall be governed by the Public Works Standards. Notification that the street is planned for future extension shall be posted on the dead-end street. [Amended by Ord. # 674 11/16/09]

Response: There are no proposed dead-end streets. This standard is not applicable.

E. Corner or clear vision area.

1. A clear vision area which meets the Public Works Standards shall be maintained on each corner of property at the intersection of any two streets, a street and a railroad or a street and a driveway. However, the following items shall be exempt from meeting this requirement:
 - a. Light and utility poles with a diameter less than 12 inches.
 - b. Trees less than 6" d.b.h., approved as a part of the Stage II Site Design, or administrative review.
 - c. Except as allowed by b., above, an existing tree, trimmed to the trunk, 10 feet above the curb.
 - d. Official warning or street sign.
 - e. Natural contours where the natural elevations are such that there can be no cross-visibility at the intersection and necessary excavation would result in an unreasonable hardship on the property owner or deteriorate the quality of the site.

F. Vertical clearance - a minimum clearance of 12 feet above the pavement surface shall be maintained over all streets and access drives.

Response: Clear vision areas will be maintained at the corner of each property.

G. Interim improvement standard. It is anticipated that all existing streets, except those in new subdivisions, will require complete reconstruction to support urban level traffic volumes. However, in most cases, existing and short-term projected traffic volumes do not warrant improvements to full Master Plan standards. Therefore, unless otherwise specified by the Development Review Board, the following interim standards shall apply.

1. Arterials - 24 foot paved, with standard sub-base. Asphalt overlays are generally considered unacceptable, but may be considered as an interim improvement based on the recommendations of the City Engineer, regarding adequate structural quality to support an overlay.
2. Half-streets are generally considered unacceptable. However, where the Development Review Board finds it essential to allow for reasonable development, a half-street may be approved. Whenever a half-street improvement is approved, it shall conform to the requirements in the Public Works Standards:
3. When considered appropriate in conjunction with other anticipated or scheduled street improvements, the City Engineer may approve street improvements with a single asphalt lift. However, adequate provision must be made for interim storm drainage, pavement transitions at seams and the scheduling of the second lift through the Capital Improvements Plan.

[Amended by Ord. 610, 5/1/06]

Response: There are no existing streets within the development site. These standards are not applicable.

(.03) Sidewalks. Sidewalks shall be provided on the public street frontage of all development. Sidewalks shall generally be constructed within the dedicated public right-of-way, but may be located outside of the right-of-way within a public easement with the approval of the City Engineer.

- A. Sidewalk widths shall include a minimum through zone of at least five feet. The through zone may be reduced pursuant to variance procedures in Section 4.196, a waiver pursuant to Section 4.118, or by authority of the City Engineer for reasons of traffic operations, efficiency, or safety.
- B. Within a Planned Development, the Development Review Board may approve a sidewalk on only one side. If the sidewalk is permitted on just one side of the street, the owners will be required to sign an agreement to an assessment in the future to construct the other sidewalk if the City Council decides it is necessary.

Response: As shown on Sheet P2.10, all sidewalks within the development site are at least 5 ft. wide. No adjustments are requested. These standards are met.

(.04) Bicycle Facilities. *Bicycle facilities shall be provided to implement the Transportation System Plan, and may include on-street and off-street bike lanes, shared lanes, bike boulevards, and cycle tracks. The design of on-street bicycle facilities will vary according to the functional classification and the average daily traffic of the facility.*

Response: The proposed street cross-sections shown on Sheet P2.10 comply with the street classifications and cross-sections identified in the Frog Pond West Master Plan. The Willow Creek Road cross-section includes bike lanes marked with sharrows to be shared with vehicular traffic; Frog Pond Lane includes a buffered bike lane; and bikes will share the vehicular lane with vehicles in the local streets. These standards are met.

(.05) Multiuse Pathways. *Pathways may be in addition to, or in lieu of, a public street. Paths that are in addition to a public street shall generally run parallel to that street, and shall be designed in accordance with the Public Works Standards or as specified by the City Engineer. Paths that are in lieu of a public street shall be considered in areas only where no other public street connection options are feasible, and are subject to the following standards.*

- A. *Paths shall be located to provide a reasonably direct connection between likely pedestrian and bicyclist destinations. Additional standards relating to entry points, maximum length, visibility, and path lighting are provided in the Public Works Standards.*
- B. *To ensure ongoing access to and maintenance of pedestrian/bicycle paths, the City Engineer will require dedication of the path to the public and acceptance of the path by the City as public right-of-way; or creation of a public access easement over the path.*

Response: Pedestrian and bicycle accessways are proposed through Tract E. This pathway will provide two connections from the site to future Khale Road and future Boeckman Creek Trail which is planned for later development to track east toward the BPA Easement Trail and South Neighborhood Trail. The Tract E pathway will provide two connections to the proposed future street and trail, and provide a connection to proposed Street E, which will allow pedestrians to connect to the future pedestrian path east of the subject site. This connection will be in Tracts D and C proposed east of lots 13 and 17, and 28-33.

The applicant acknowledges that the pedestrian pathway will need to be extended from Street E, across Tract D to connect with the property to the east and will accept the requirement as a Condition of Approval. The exact location of the trail on the development to the east (Frog Pond Crossing) is not yet established. Once the development to the east provides the location of the pathway, the applicant will construct the path from Street E, through Tract D, to make the connection.

(.06) Transit Improvements

Development on sites that are adjacent to or incorporate major transit streets shall provide improvements as described in this section to any bus stop located along the site's frontage, unless waived by the City Engineer for reasons of safety or traffic operations. Transit facilities include bus stops, shelters, and related facilities. Required transit facility improvements may include the dedication of land or the provision of a public easement.[...]

Response: The site is not adjacent to nor incorporates a major transit street. These standards are not applicable.

(.07) Residential Private Access Drives. *Residential Private Access Drives shall meet the following standards:*

- A. *Residential Private Access Drives shall provide primary vehicular access to no more than four (4) dwelling units, excluding accessory dwelling units.*

Response: There are no private drives or accessways proposed. This standard is not applicable.

- B. *The design and construction of a Residential Private Access Drive shall ensure a useful lifespan and structural maintenance schedule comparable, as determined by the City Engineer or City's Authorized Representative, to a local street constructed in conformance to current public works standards.*

1. *The design of residential private access drives shall be stamped by a professional engineer registered in the state of Oregon and shall be approved by the City Engineer or City's Authorized Representative to ensure the above requirement is met.*
2. *Prior to issuing a certificate of occupancy for any residential dwelling unit whose primary vehicular access is from a Residential Private Access Drive the City Engineer or City's Authorized Representative shall certify construction of the Residential Private Access Drive substantially conforms the design approved by the City Engineer or City's Authorized Representative.*

Response: At the time of construction document submittal, the design shall be stamped by a professional engineer registered in the state of Oregon. These standards will be met.

- C. *Residential Private Access Drives shall be named for addressing purposes. All Residential Private Access Drives shall use the suffix "Lane", i.e. SW Oakview Lane.*
- D. *Residential Private Access Drives shall meet or exceed the standards for access drives and travel lanes established in Subsection (.08) of this Section.*

[Amended by Ord. 682, 9/1/10]

Response: There are no private drives or accessways proposed. This standard is not applicable.

- P. *Unless constrained by topography, natural resources, rail lines, freeways, existing or planned or approved development, or easements or covenants, driveways proposed as part of a residential or mixed-use development shall meet local street spacing standards and shall be constructed to align with existing or planned streets, if the driveway.*
 1. *Intersects with a public street that is controlled, or is to be controlled in the planning period, by a traffic signal;*
 2. *Intersects with an existing or planned arterial or collector street; or*
 3. *Would be an extension of an existing or planned local street, or of another major driveway.*

Response: Locations of driveways within the subdivision are provided on Sheet P2.00 as conceptual locations. Driveway locations will be verified at the time of building permit review.

(.08). Access Drive and Driveway Approach Development Standards.

Response: There are no private drives or accessways proposed. This standard is not applicable.

- A. *An access drive to any proposed development shall be designed to provide a clear travel lane free from any obstructions.*
- B. *Access drive travel lanes shall be constructed with a hard surface capable of carrying a 23-ton load.*
- C. *Where emergency vehicle access is required, approaches and driveways shall be designed and constructed to accommodate emergency vehicle apparatus and shall conform to applicable fire protection requirements. The City may restrict parking, require signage, or require other public safety improvements pursuant to the recommendations of an emergency service provider.*
- D. *Secondary or emergency access lanes may be improved to a minimum 12 feet with an all-weather surface as approved by the Fire District. All fire lanes shall be dedicated easements.*

Response: There are no private drives or accessways proposed. This standard is not applicable.

[...]

(.09) Minimum street intersection spacing standards.

- A. *New streets shall intersect at existing street intersections so that centerlines are not offset. Where existing streets adjacent to a proposed development do not align properly, conditions shall be imposed on the development to provide for proper alignment.*
- B. *Minimum intersection spacing standards are provided in Transportation System Plan Table 3-2.*

Response: The streets within the development are local streets, except for Willow Creek Drive and Frog Pond Lane, which are Collectors. Per Table 3-2 of the TSP, minimum access spacing standards along a Collector is 100 ft., and the desired access spacing is 300 ft. All proposed local street connections to Willow Creek Drive and Frog Pond Lane exceed the minimum access spacing standard of 100 ft. In most

cases, access spacing is approximately 200 ft. to accommodate a side lot orientation to Collector streets while adhering as close as possible to the Frog Pond West Street Demonstration Plan.

No individual lot accesses are proposed to Willow Creek Drive or Frog Pond Lane, and access to each proposed lot will be taken from local streets. These standards are met.

(.10) Exceptions and Adjustments. *The City may approve adjustments to the spacing standards of subsections (.08) and (.09) above through a Class II process, or as a waiver per Section 4.118(.03)(A.), where an existing connection to a City street does not meet the standards of the roadway authority, the proposed development moves in the direction of code compliance, and mitigation measures alleviate all traffic operations and safety concerns. Mitigation measures may include consolidated access (removal of one access), joint use driveways (more than one property uses same access), directional limitations (e.g., one-way), turning restrictions (e.g., right in/out only), or other mitigation. [Section 4.177 amended by Ord. 719, 6/17/13]*

Response: The proposed street, pedestrian and bicycle connectivity are design to be in substantial conformance to the Frog Pond West Master Plan; no exceptions or adjustments to the spacing standards are requested.

J. Section 4.180. Exceptions and Modifications - Projections into Required Yards.

(.01) *Certain non-structural architectural features are permitted to project into required yards or courts, without requiring the approval of a Variance or Reduced Setback Agreement, as follows:*

A. *Into any required yard:*

1. *Architectural features may project into the required yard not more than two (2) inches for each foot of required setback.*
2. *Open, unenclosed fire escapes may project a distance not exceeding forty-eight (48) inches.*

B. *Into any required yard, adjoining a street or tract with a private drive: [Amended by Ord. 682, 9/9/10]*

1. *Architectural features may project a distance not exceeding forty (40) inches.*
2. *An uncovered porch, terrace, or patio extending no more than two and one-half (2 1/2) feet above the finished elevation may extend within three (3) feet of an interior side lot line, or within ten (10) feet of a front lot line or of an exterior side lot line.*

Response: No buildings are proposed with this application. These provisions are not applicable.

K. Section 4.181. Exceptions & Modifications - Height Limits.

Except as stipulated in Sections 4.800 through 4.804, height limitations specified elsewhere in this Code shall not apply to barns, silos or other farm buildings or structures on farms; to church spires; belfries; cupolas; and domes; monuments; water towers; windmills; chimneys; smokestacks; fire and hose towers; flag poles; above-ground electric transmission, distribution, communication and signal lines, towers and poles; and properly screened mechanical and elevator structures.

Response: No listed structures are proposed at this time. These provisions are not applicable.

L. Section 4.182. Exceptions and Modifications - Setback Modifications.

In any residential zone where the average depth of at least two (2) existing front yards on adjoining lots or within one hundred fifty (150) feet of the lot in question and within the same block front is less or greater than the minimum or maximum front yard depth prescribed elsewhere in this Code, the required depth of the front yard on such lot shall be modified. In such case, the front yard depth shall not be less than the average depth, nor more than the greater depth, of existing front yards on at least two (2) adjoining lots within one hundred and fifty (150) feet. In the case of a corner lot, the depth of the front yard may be reduced to that of the lot immediately adjoining, provided, however, that the depth of a front yard on any corner lot shall be at least ten (10) feet.

Response: No setback modifications are requested under the provisions of this section. These provisions are not applicable.

M. Section 4.197. Zone Changes and Amendments To This Code – Procedures.

(.01) The following procedure shall be followed in applying for an amendment to the text of this Chapter:[...]

Response: No zoning text amendments are proposed. This procedure is not applicable.

(.02) The following procedures shall be followed for zone map amendments. :

Response: An amendment to the zoning map is proposed as part of this project. Therefore, the criteria in this section apply.

[...]

(C) In recommending approval or denial of a proposed zone map amendment, the Planning Commission or Development Review Board shall at a minimum, adopt findings addressing the following criteria:

- 1. That the application before the Commission or Board was submitted in accordance with the procedures set forth in Section 4.008, Section 4.125 (.18)(B)(2) or, in the case of a Planned Development, Section 4.140; and [Amended by Ord 557, adopted 9/5/03]*

Response: The zone map amendment is being requested concurrent with a Planned Development. The application has been submitted in accordance with the procedures set forth in Section 4.140. This criterion is met.

- 2. That the proposed amendment is consistent with the Comprehensive Plan map designation and substantially complies with the applicable goals, policies and objectives, set forth in the Comprehensive Plan text; and*

Response: The Comprehensive Plan map designation for the Frog Pond Oaks site is Residential Neighborhood RN, which is implemented by the requested Residential Neighborhood RN zone.

The applicable goals, policies, and objectives of the Comprehensive Plan text are addressed in Section III of this narrative. This criterion is met.

- 3. In the event that the subject property, or any portion thereof, is designated as "Residential" on the City's Comprehensive Plan Map; specific findings shall be made addressing substantial compliance with Implementation Measures 4.1.4.b, d, e, q, and x of Wilsonville's Comprehensive Plan text; and*

Response: The Frog Pond Oaks site is designated "Residential" on the City's Comprehensive Plan Map. Compliance with Implementation Measures 4.1.4.b, d, e, q, and x is addressed in Section III of this narrative. This criterion is met.

- 4. That the existing primary public facilities, i.e., roads and sidewalks, water, sewer and storm sewer are available and are of adequate size to serve the proposed development; or, that adequate facilities can be provided in conjunction with project development. The Planning Commission and Development Review Board shall utilize any and all means to insure that all primary facilities are available and are adequately sized; and*

Response: As addressed elsewhere in this narrative the development will extend roads and sidewalks, water, sewer, and storm sewer to serve the proposed development. This criterion is met.

- 5. That the proposed development does not have a significant adverse effect upon Significant Resource Overlay Zone areas, an identified natural hazard, or an identified geologic hazard. When Significant Resource Overlay Zone areas or natural hazard, and/or geologic hazard are located on or about the proposed development, the Planning Commission or Development Review Board shall use appropriate measures to mitigate and significantly reduce conflicts between the development and identified hazard or Significant Resource Overlay Zone and*

Response: The site does not contain an SROZ area. This criterion is not applicable.

6. *That the applicant is committed to a development schedule demonstrating that development of the property is reasonably expected to commence within two (2) years of the initial approval of the zone change; and*

Response: The zone change request is being submitted concurrently with a planned development, subdivision, and site plan review application. The applicant is committed to develop the property as soon as these applications and related site development permits are approved, which is expected to occur by fall 2022. This criterion is met.

7. *That the proposed development and use(s) can be developed in compliance with the applicable development standards or appropriate conditions are attached that insure that the project development substantially conforms to the applicable development standards.*

Response: The proposed development and use is single-family residential in accordance with the Frog Pond West Master Plan. Compliance with the applicable development standards of the RN zone is addressed Section IV of this narrative.

8. *Adequate public facilities, services, and transportation networks are in place, or are planned to be provided concurrently with the development of the property. The applicant shall demonstrate compliance with the Transportation Planning Rule, specifically by addressing whether the proposed amendment has a significant effect on the transportation system pursuant to OAR 660-012-0060. A Traffic Impact Analysis (TIA) shall be prepared pursuant to the requirements in Section 4.133.05.(01).*

Response: Adequate public facilities, services, and transportation networks are in place, or are planned to be provided concurrently with the proposed development. The development will extend sewer and water infrastructure into the development from existing infrastructure in Frog Pond Lane, and will provide storm drainage facilities to serve the development. See Sheet P4.00 and Appendix B Preliminary Drainage Report.

The proposed development includes an internal roadway network in substantial conformance with the Frog Pond Area Plan, and includes improvements to the north side of Frog Pond Lane, the extension of Willow Creek Drive, and internal local streets. The development will provide frontage improvements along Frog Pond Lane in coordination with the City's planned design and reconstruction of the roadway along the project boundary. A Traffic Impact Analysis will be prepared by DKS at the direction of the City of Wilsonville and will be included in this application, once available, as Appendix C.

Compliance with the TPR is included in the Frog Pond Area Plan and assumes full development of the Frog Pond area. This criterion is met.

(.03) If affirmative findings cannot be made for all applicable criteria listed above the Planning Commission or Development Review Board shall recommend that the proposed text or map amendment, as the case may be, be denied.

(.04) City Council action approving a change in zoning shall be in the form of a Zoning Order.

(.05) In cases where a property owner or other applicant has requested a change in zoning and the City Council has approved the change subject to conditions, the owner or applicant shall sign a statement accepting, and agreeing to complete the conditions of approval before the zoning shall be changed.

Response: The proposed development meets the applicable criteria as described above.

VI. Land Divisions

A. Section 4.210. Application Procedure.

(.01) Pre-application conference. Prior to submission of a tentative condominium, partition, or subdivision plat, a person proposing to divide land in the City shall contact the Planning Department to arrange a pre-application conference as set forth in Section 4.010.

A. Preparation of Tentative Plat. The Planning staff shall provide information regarding procedures and general information having a direct influence on the proposed development, such as elements of the

Comprehensive Plan, existing and proposed streets, roads and public utilities. The applicant shall cause to be prepared a tentative plat, together with improvement plans and other supplementary material as specified in this Section. The Tentative Plat shall be prepared by an Oregon licensed professional land surveyor or engineer. An affidavit of the services of such surveyor or engineer shall be furnished as part of the submittal.

- B. Tentative Plat Submission. The purpose of the Tentative Plat is to present a study of the proposed subdivision to the Planning Department and Development Review Board and to receive approval or recommendations for revisions before preparation of a final Plat. The design and layout of this plan plat shall meet the guidelines and requirements set forth in this Code. The Tentative Plat shall be submitted to the Planning Department with the following information:*
- 1. Site development application form completed and signed by the owner of the land or a letter of authorization signed by the owner. A preliminary title report or other proof of ownership is to be included with the application form.*
 - 2. Application fees as established by resolution of the City Council.*
 - 3. Ten (10) copies and one (1) sepia or suitable reproducible tracing of the Tentative Plat shall be submitted with the application. Paper size shall be eighteen inch (18") by twenty-four inch (24"), or such other size as may be specified by the City Engineer.*
 - 4. Name of the subdivision. No subdivision name shall duplicate or resemble the name of any other subdivision in Clackamas or Washington County. Names may be checked through the county offices.*
 - 5. Names, addresses, and telephone numbers of the owners and applicants, and engineer or surveyor.*
 - 6. Date, north point and scale of drawing.*
 - 7. Location of the subject property by Section, Township, and Range.*
 - 8. Legal road access to subject property shall be indicated as City, County, or other public roads.*
 - 9. Vicinity map showing the relationship to the nearest major highway or street.*
 - 10. Lots: Dimensions of all lots, minimum lot size, average lot size, and proposed lot and block numbers.*
 - 11. Gross acreage in proposed plat.*
 - 12. Proposed uses of the property, including sites, if any, for multi-family dwellings, shopping centers, churches, industries, parks, and playgrounds or other public or semi-public uses.*
 - 13. Improvements: Statement of the improvements to be made or installed including streets, private drives, sidewalks, lighting, tree planting, and times such improvements are to be made or completed. [Amended by Ord. 682, 9/9/10]*
 - 14. Trees. Locations, types, sizes, and general conditions of all existing trees, as required in Section 4.600.*
 - 15. Utilities such as electrical, gas, telephone, on and abutting the tract.*
 - 16. Easements: Approximate width, location, and purpose of all existing and proposed easements on, and known easements abutting the tract.*
 - 17. Deed Restrictions: Outline of proposed deed restrictions, if any.*
 - 18. Written Statement: Information which is not practical to be shown on the maps may be shown in separate statements accompanying the Tentative Plat.*
 - 19. If the subdivision is to be a "Planned Development," a copy of the proposed Home Owners Association By-Laws must be submitted at the time of submission of the application. The Tentative Plat shall be considered as the Stage I Preliminary Plan. The proposed By-Laws must address the maintenance of any parks, common areas, or facilities.*
 - 20. Any plat bordering a stream or river shall indicate areas subject to flooding and shall comply with the provisions of Section 4.172.*
 - 21. Proposed use or treatment of any property designated as open space by the City of Wilsonville.*
 - 22. A list of the names and addresses of the owners of all properties within 250 feet of the subject property, printed on self-adhesive mailing labels. The list shall be taken from the latest available property ownership records of the Assessor's office of the affected county.*
 - 23. A completed "liens and assessments" form, provided by the City Finance Department.*
 - 24. Locations of all areas designated as a Significant Resource Overlay Zone by the City, as well as any wetlands shall be shown on the tentative plat.*
 - 25. Locations of all existing and proposed utilities, including but not limited to domestic water, sanitary sewer, storm drainage, and any private utilities crossing or intended to serve the site. Any plans to phase the construction or use of utilities shall be indicated. [Amended by Ord. 682, 9/9/10]*

26. A traffic study, prepared under contract with the City, shall be submitted as part of the tentative plat application process, unless specifically waived by the Community Development Director.

C. Action on proposed tentative plat:

[...]

D. Land division phases to be shown. Where the applicant intends to develop the land in phases, the schedule of such phasing shall be presented for review at the time of the tentative plat. In acting on an application for tentative plat approval, the Planning Director or Development Review Board may set time limits for the completion of the phasing schedule which, if not met, shall result in an expiration of the tentative plat approval.

E. Remainder tracts to be shown as lots or parcels. Tentative plats shall clearly show all affected property as part of the application for land division. All remainder tracts, regardless of size, shall be shown and counted among the parcels or lots of the division.

[...]

Response: A Subdivision is requested to create the lots proposed by the Planned Development. The information described above is included with this submittal. A Preliminary Plat is included as Sheet 3.00; a Preliminary Utility Plan is included as Sheet P4.00; a Tree Removal and Protection Plan is included as Sheet L1.00; Preliminary Street Cross-Sections are included as Sheets P2.10; Street Lighting Plans are included as Sheets IL-1 to IL-4; and draft Homeowner Association Bylaws and CC&Rs are included as Appendix G.

B. Section 4.236. General Requirements - Streets.

(.01) *Conformity to the Transportation System Plan. Land divisions shall conform to and be in harmony with the Transportation Systems Plan, the Bicycle and Pedestrian Master Plan, and the Parks and Recreation Master Plan. [Amended by Ord. #719, 6/17/13]*

Response: As shown in the TIA included as Appendix C, the proposed street plan conforms to the Transportation System Plan and is in substantial conformance with the Frog Pond West Master Plan.

The 2006 Bicycle and Pedestrian Master Plan identifies an improvement, Community Walkway/Bikeway C10, within the site area. The 2017 Frog Pond West Master Plan incorporates a Bicycle and Pedestrian Framework (Figure 17), which identifies bicycle lanes, or shared auto-bicycle lane with sharrows, and sidewalks along Willow Creek Drive and Frog Pond Lane adjacent to the project frontage. The development will construct Willow Creek Drive and the bicycle/pedestrian facilities associated with it.

The 2018 Parks and Recreation Master Plan identifies a Future School and a Future Outdoor Recreation Location (defined in the Frog Pond West Master Plan as a neighborhood park) south of the subject site and east of the future school site. the Frog Pond West area. The 2017 Frog Pond West Master Plan defines the types of parks and open space anticipated within the Frog Pond West area. Proposed street improvements will provide access to the future neighborhood park location, identified southwest of the site.

(.02) **Relation to Adjoining Street System.**

A. *A land division shall provide for the continuation of the principal streets existing in the adjoining area, or of their proper projection when adjoining property is not developed, and shall be of a width not less than the minimum requirements for streets set forth in these regulations. Where, in the opinion of the Planning Director or Development Review Board, topographic conditions make such continuation or conformity impractical, an exception may be made. In cases where the Board or Planning Commission has adopted a plan or plat of a neighborhood or area of which the proposed land division is a part, the subdivision shall conform to such adopted neighborhood or area plan.*

B. *Where the plat submitted covers only a part of the applicant's tract, a sketch of the prospective future street system of the unsubmitted part shall be furnished and the street system of the part submitted shall be considered in the light of adjustments and connections with the street system of the part not submitted.*

C. *At any time when an applicant proposes a land division and the Comprehensive Plan would allow for the proposed lots to be further divided, the city may require an arrangement of lots and streets such as to permit a later resubdivision in conformity to the street plans and other requirements specified in these regulations.*

Response: As shown in Sheet P8.00, the proposed street network is designed for future continuation per the Frog Pond West Master Plan. Proposed Streets C and D provide connection points for future development to the east; proposed Street E provides a connection from proposed Street D to future Kahle Road; Willow Creek Drive will connect with future development to the west and the north. These standards are met.

(.03) *All streets shall conform to the standards set forth in Section 4.177 and the block size requirements of the zone.*

Response: The standards of Section 4.177 are addressed in Section V of this narrative.

(.04) Creation of Easements: *The Planning Director or Development Review Board may approve an easement to be established without full compliance with these regulations, provided such an easement is the only reasonable method by which a portion of a lot large enough to allow partitioning into two (2) parcels may be provided with vehicular access and adequate utilities. If the proposed lot is large enough to divide into more than two (2) parcels, a street dedication may be required. [Amended by Ord. 682, 9/9/10]*

Response: No street easements are proposed. This standard is not applicable.

(.05) Topography: *The layout of streets shall give suitable recognition to surrounding topographical conditions in accordance with the purpose of these regulations.*

Response: The street layout recognizes topographical conditions, specifically the location of trees on site. This standard is met.

(.06) Reserve Strips: *The Planning Director or Development Review Board may require the applicant to create a reserve strip controlling the access to a street. Said strip is to be placed under the jurisdiction of the City Council, when the Director or Board determine that a strip is necessary:*

- A. *To prevent access to abutting land at the end of a street in order to assure the proper extension of the street pattern and the orderly development of land lying beyond the street; or*
- B. *To prevent access to the side of a street on the side where additional width is required to meet the right-of-way standards established by the City; or*
- C. *To prevent access to land abutting a street of the land division but not within the tract or parcel of land being divided; or*
- D. *To prevent access to land unsuitable for building development.*

Response: No reserve strip is proposed. The applicant acknowledges that the DRB may require that the applicant create a reserve strip. This standard is met.

(.07) Future Expansion of Street: *When necessary to give access to, or permit a satisfactory future division of, adjoining land, streets shall be extended to the boundary of the land division and the resulting dead-end street may be approved without a turn-around. Reserve strips and street plugs shall be required to preserve the objective of street extension. Notification that the street is planned for future extension shall be posted on the stub street. [Amended by Ord. #719, 6/17/13]*

Response: Willow Creek Drive, Larkspur Terr, and Marigold Terr have been extended to the boundaries of the site and are intended for future extension. For that reason, no turnarounds are proposed for these streets. The applicant will comply with any requirements related to signage street extension objectives. This standard is met.

(.08) Existing Streets: *Whenever existing streets adjacent to or within a tract are of inadequate width, additional right-of-way shall conform to the designated width in this Code or in the Transportation Systems Plan.*

Response: Frog Pond Lane to the south of the site is of inadequate width. The project will dedicate 21.5 ft. of additional right-of-way to the street. Willow Creek Drive to the west has not yet been extended north of Frog Pond Lane but will be along with the development of this property. In addition, 42.7 ft. from the subject property's west boundary will be dedicated to serve as right-of-way for Willow Creek Drive, from

Frog Pond Lane, to proposed Street D. Seven feet will be dedicated for the future development of Marigold Terr to the east. Two feet will be dedicated from the property's northern boundary for the future development of Kahle Road. This standard is met.

(.09) Street Names: *No street names will be used which will duplicate or be confused with the names of existing streets, except for extensions of existing streets. Street names and numbers shall conform to the established name system in the City, and shall be subject to the approval of the City Engineer.*

Response: Willow Creek Drive is an Interior Collector per the Frog Pond West Master Plan, and Larkspur Terrace and Marigold Terrace have been established by previous development applications. Streets C, D, and E will conform to the City's established name system and will be subject to approval by the City Engineer. This standard is met.

C. Section 4.237. General Requirements – Other.

(.01) Blocks:

- A. *The length, width, and shape of blocks shall be designed with due regard to providing adequate building sites for the use contemplated, consideration of needs for convenient access, circulation, control, and safety of pedestrian, bicycle, and motor vehicle traffic, and recognition of limitations and opportunities of topography.*
- B. *Sizes: Blocks shall not exceed the sizes and lengths specified for the zone in which they are located unless topographical conditions or other physical constraints necessitate larger blocks. Larger blocks shall only be approved where specific findings are made justifying the size, shape, and configuration.*

Response: The length, width, and shape of blocks have been designed in substantial conformance with the Frog Pond West Master Plan and to comply with the standards of Section 4.177. These standards are addressed in section V of this narrative. The site is located within the RN zone and is also subject to the block, access, and connectivity standards of Section 4.127(.10). Those standards are addressed in Section IV.E of this narrative. These standards are met.

(.02) Easements:

- A. *Utility lines. Easements for sanitary or storm sewers, drainage, water mains, electrical lines or other public utilities shall be dedicated wherever necessary. Easements shall be provided consistent with the City's Public Works Standards, as specified by the City Engineer or Planning Director. All of the public utility lines within and adjacent to the site shall be installed within the public right-of-way or easement; with underground services extending to the private parcel constructed in conformance to the City's Public Works Standards. All franchise utilities shall be installed within a public utility easement. All utilities shall have appropriate easements for construction and maintenance purposes. [Amended by Ord. 682, 9/9/10]*
- B. *Water courses. Where a land division is traversed by a water course, drainage way, channel or stream, there shall be provided a storm water easement or drainage right-of-way conforming substantially with the lines of the water course, and such further width as will be adequate for the purposes of conveying storm water and allowing for maintenance of the facility or channel. Streets or parkways parallel to water courses may be required.*

Response: Public utilities are placed within public rights-of-way or within public utility easements (PUE) adjacent to the public streets. There are proposed stormwater facility easements where these facilities are located on private property and are intended to be shared between more than one lot. A mature tree grove in the northwest portion of the site has been placed within Tract E, and mature trees along the site's eastern boundary are placed in Tract D for preservation. Temporary looping of the water line from Street D is provided in an easement through Tract C. The water line will be extended for future development in the property to the east. See P4.00 for proposed water line loop and easement through Tract C.

(.03) Pedestrian and bicycle pathways. *An improved public pathway shall be required to transverse the block near its middle if that block exceeds the length standards of the zone in which it is located.*

- A. *Pathways shall be required to connect to cul-de-sacs or to pass through unusually shaped blocks.*
- B. *Pathways required by this subsection shall have a minimum width of ten (10) feet unless they are found to be unnecessary for bicycle traffic, in which case they are to have a minimum width of six (6) feet.*

Response: Provisions for guiding the design of pedestrian and bicycle connectivity in the Frog Pond West area are provided by the Street Demonstration Plan of the Frog Pond West Master Plan and supersede the provisions of this section. Pedestrian connections on the subject site are proposed through a network of local streets, through the active open space Tract E, and by reserving open space along the site's eastern boundary in Tracts D and C. Tracts D and C will meet future pedestrian accessways on the site directly east to form a cohesive and practical pedestrian connection system. As discussed above in this report, the Street Demonstration Plan, in conjunction with mitigating on-site factors such as the preservation of native trees and the elevation-dictated stormwater facility placement, shaped the proposed pedestrian and bicycle connection system. The proposed design is substantially consistent with the Street Demonstration Plan.

(.04) Tree planting. *Tree planting plans for a land division must be submitted to the Planning Director and receive the approval of the Director or Development Review Board before the planting is begun. Easements or other documents shall be provided, guaranteeing the City the right to enter the site and plant, remove, or maintain approved street trees that are located on private property.*

Response: Tree planting plans are included as Sheet L2.00. Proposed street trees are located within public right-of-way and additional easements should not be needed. This standard is met.

(.05) Lot Size and shape. *The lot size, width, shape and orientation shall be appropriate for the location of the land division and for the type of development and use contemplated. Lots shall meet the requirements of the zone where they are located.*

- A. *In areas that are not served by public sewer, an on-site sewage disposal permit is required from the City. If the soil structure is adverse to on-site sewage disposal, no development shall be permitted until sewer service can be provided.*
- B. *Where property is zoned or deeded for business or industrial use, other lot widths and areas may be permitted at the discretion of the Development Review Board. Depth and width of properties reserved or laid out for commercial and industrial purposes shall be adequate to provide for the off-street service and parking facilities required by the type of use and development contemplated.*
- C. *In approving an application for a Planned Development, the Development Review Board may waive the requirements of this section and lot size, shape, and density shall conform to the Planned Development conditions of approval.*

Response: The site is served by public sewer, and no on-site sewage disposal is proposed. The property is zoned for residential purposes and is subject to an application for a Planned Development. The site is located within the RN zone and is subject to the standards of that zone. The proposed lots meet the dimensional standards of the RN zone and the R-7 and R-5 sub-districts. These standards are met.

(.06) Access. *The division of land shall be such that each lot shall have a minimum frontage on a street or private drive, as specified in the standards of the relative zoning districts. This minimum frontage requirement shall apply with the following exceptions:*

- A. *A lot on the outer radius of a curved street or tract with a private drive, or facing the circular end of a cul-de-sac shall have frontage of not less than twenty-five (25) feet upon a street or tract with a private drive, measured on the arc.*
- B. *The Development Review Board may waive lot frontage requirements where in its judgment the waiver of frontage requirements will not have the effect of nullifying the intent and purpose of this regulation or if the Board determines that another standard is appropriate because of the characteristics of the overall development.*

[Section 4.237(.06) amended by Ord. 682, 9/9/10]

Response: The minimum lot width in the RN zone/R-7 subdistrict is 35 ft; and the minimum lot width in the RN zone/R-5 subdistrict is 35 ft. As detailed in the response to Section 4.127 and shown on Sheet P3.00, each lot has frontage of at least 35 ft. on a public street. These standards are met.

(.07) Through lots. *Through lots shall be avoided except where essential to provide separation of residential development from major traffic arteries or adjacent non-residential activity or to overcome specific disadvantages of topography and orientation. A planting screen easement of at least ten (10) feet, across which there shall be no access, may be required along the line of lots abutting such a traffic artery or other disadvantageous use. Through lots with planting screens shall have a minimum average depth of one hundred (100) feet. The Development Review Board may require assurance that such*

screened areas be maintained as specified in Section 4.176.

Response: There are no through-lots proposed as a part of this project. This standard is not applicable.

(.08) Lot side lines. *The side lines of lots, as far as practicable for the purpose of the proposed development, shall run at right angles to the street or tract with a private drive upon which the lots face. [Amended by Ord. 682, 9/9/10]*

Response: With the exception of proposed Lot 41, all side lot lines run at right angles to the street or the tract upon which they face. Due to the proposed westerly projection of Willow Creek Drive, which is designed to avoid a grove of mature trees, proposed Lot 41's western side property line is angled at 124 degrees to allow access to Tract E from within the subject property. This standard is met.

(.09) Large lot land divisions. *In dividing tracts which at some future time are likely to be re-divided, the location of lot lines and other details of the layout shall be such that re-division may readily take place without violating the requirements of these regulations and without interfering with the orderly development of streets. Restriction of buildings within future street locations shall be made a matter of record if the Development Review Board considers it necessary.*

Response: No future development tracts are proposed.

(.10) Building line. *The Planning Director or Development Review Board may establish special building setbacks to allow for the future re-division or other development of the property or for other reasons specified in the findings supporting the decision. If special building setback lines are established for the land division, they shall be shown on the final plat.*

Response: No special building setbacks are proposed.

(.11) Build-to line. *The Planning Director or Development Review Board may establish special build to lines for the development, as specified in the findings and conditions of approval for the decision. If special build-to lines are established for the land division, they shall be shown on the final plat.*

Response: There is no maximum setback in the RN zones, and no build-to-lines are proposed.

(.12) Land for public purposes. *The Planning Director or Development Review Board may require property to be reserved for public acquisition, or irrevocably offered for dedication, for a specified period of time.*

Response: The City has not identified any requirements for property to be reserved for public acquisition. The development will dedicate right-of-way for the public street network.

(.13) Corner lots. *Lots on street intersections shall have a corner radius of not less than ten (10) feet.*

Response: As shown on Sheet P3.00, lots on street intersections have corner radii of at least 20 ft. This standard is met.

D. Section 4.262. Improvements - Requirements.

(.01) Streets. *Streets within or partially within the development shall be graded for the entire right-of-way width, constructed and surfaced in accordance with the Transportation Systems Plan and City Public Works Standards. Existing streets which abut the development shall be graded, constructed, reconstructed, surfaced or repaired as determined by the City Engineer.*

(.02) Curbs. *Curbs shall be constructed in accordance with standards adopted by the City.*

(.03) Sidewalks. *Sidewalks shall be constructed in accordance with standards adopted by the City.*

Response: As shown on Sheets P2.10, streets will be graded, constructed, and surfaced according to the TSP, the cross-sections incorporated into the Frog Pond West Master Plan, and the City's Public Works Standards as modified by the City Engineer. These standards are met.

(.04) Sanitary sewers. *When the development is within two hundred (200) feet of an existing public sewer main, sanitary sewers shall be installed to serve each lot or parcel in accordance with standards adopted by the City. When the development is more than two hundred (200) feet from an existing public*

sewer main, the City Engineer may approve an alternate sewage disposal system.

(.05) Drainage. Storm drainage, including detention or retention systems, shall be provided as determined by the City Engineer.

Response: The proposed development will be served by public sanitary sewer. Storm drainage systems are being provided as outlined in the City's Site Assessment and Planning standards. LIDA facilities are proposed within the Frog Pond Ln street frontage.

See Sheet P2.00 for the location of LIDA facilities within the planter strips of Frog Pond Ln, Willow Creek Drive, Street C, and Street D. See Sheet P4.00 for the location of stormwater facilities within Tracts A and B. See Sheet L2.30 for details of the LIDA facilities planting; and see Appendix B for the Preliminary Drainage Plan, including a downstream analysis and evaluation of capacity. These standards are met.

(.06) Underground utility and service facilities. All new utilities shall be subject to the standards of Section 4.300 (Underground Utilities). The developer shall make all necessary arrangements with the serving utility to provide the underground services in conformance with the City's Public Works Standards.

Response: The standards of Section 4.300 are addressed in Section VII of this narrative. These standards are met.

(.07) Streetlight standards. Streetlight standards shall be installed in accordance with regulations adopted by the City.

Response: Streetlights will be installed per the Frog Pond West Master Plan and regulations adopted by the City. Figure 42 of the Frog Pond West Master Plan identifies the streets within the development site (Frog Pond Ln, Willow Creek Drive, Larkspur Terrace, Streets C, D, and E) as Local Streets. The western portion of Street C is shown as a Pedestrian Connections in this figure. Street C is proposed as a local street in place of a Pedestrian Connection and the local street lighting standard is proposed for Street C. The Master Plan calls for the use of the Philips Hadco LED Westbrooke fixture for local streets. As shown in Sheets IL-1 to IL-4, these fixtures are proposed on all streets.

Tract E is proposed as a Pedestrian Path/Connection. The Master Plan calls for compliance with City of Wilsonville Public Works Standards Chapter 201.9.02 Shared-Use Path Lighting for Pedestrian Connections. These standards do not reference a preferred light fixture but refer to horizontal and vertical illuminance and uniformity values. Sheet IL-4 provides detail of the lighting plan for Tract E, which is in compliance with the Frog Pond West Master Plan requirements. A photometric analysis can be provided prior to site permitting to verify compliance with the City's Public Works Standards.

(.08) Street signs. Street name signs shall be installed at all street intersections and dead-end signs at the entrance to all dead-end streets and cul-de-sacs in accordance with standards adopted by the City. Other signs may be required by the City Engineer.

Response: Street signs will be installed per City standards.

(.09) Monuments. Monuments shall be placed at all lot and block corners, angle points, points of curves in streets, at intermediate points and shall be of such material, size and length as required by State Law. Any monuments that are disturbed before all improvements are completed by the developer and accepted by the City shall be replaced to conform to the requirements of State Law.

Response: Monuments will be placed per State, Clackamas County, and City requirements.

(.10) Water. Water mains and fire hydrants shall be installed to serve each lot in accordance with City standards.

Response: Water mains and fire hydrants are proposed to serve each lot in accordance with City and Fire Department standards. See Sheet P4.00.

VII. Underground Utilities

A. Section 4.300 General.

(.01) The City Council deems it reasonable and necessary in order to accomplish the orderly and desirable development of land within the corporate limits of the City, to require the underground installation of utilities in all new developments.

(.02) After the effective date of this Code, the approval of any development of land within the City will be upon the express condition that all new utility lines, including but not limited to those required for power, communication, street lighting, gas, cable television services and related facilities, shall be placed underground.

(.03) The construction of underground utilities shall be subject to the City's Public Works Standards and shall meet applicable requirements for erosion control and other environmental protection.

Response: The proposed development is subject to the requirements of this section.

B. Section 4.320. Requirements.

(.01) The developer or subdivider shall be responsible for and make all necessary arrangements with the serving utility to provide the underground services (including cost of rearranging any existing overhead facilities). All such underground facilities as described shall be constructed in compliance with the rules and regulations of the Public Utility Commission of the State of Oregon relating to the installation and safety of underground lines, plant, system, equipment and apparatus.

(.02) The location of the buried facilities shall conform to standards supplied to the subdivider by the City. The City also reserves the right to approve location of all surface-mounted transformers.

(.03) Interior easements (back lot lines) will only be used for storm or sanitary sewers, and front easements will be used for other utilities unless different locations are approved by the City Engineer. Easements satisfactory to the serving utilities shall be provided by the developer and shall be set forth on the plat.

Response: New utilities will be installed underground in accordance with City and other agency requirements. These standards are met.

VIII. Site Design Review

A. Section 4.400. Purpose.

(.01) Excessive uniformity, inappropriateness or poor design of the exterior appearance of structures and signs and the lack of proper attention to site development and landscaping in the business, commercial, industrial and certain residential areas of the City hinders the harmonious development of the City, impairs the desirability of residence, investment or occupation in the City, limits the opportunity to attain the optimum use in value and improvements, adversely affects the stability and value of property, produces degeneration of property in such areas and with attendant deterioration of conditions affecting the peace, health and welfare, and destroys a proper relationship between the taxable value of property and the cost of municipal services therefor.

(.02) The City Council declares that the purposes and objectives of site development requirements and the site design review procedure are to:

- A. *Assure that Site Development Plans are designed in a manner that insures proper functioning of the site and maintains a high quality visual environment.*
- B. *Encourage originality, flexibility and innovation in site planning and development, including the architecture, landscaping and graphic design of said development;*
- C. *Discourage monotonous, drab, unsightly, dreary and inharmonious developments;*
- D. *Conserve the City's natural beauty and visual character and charm by assuring that structures, signs and other improvements are properly related to their sites, and to surrounding sites and structures, with due regard to the aesthetic qualities of the natural terrain and landscaping, and that proper attention is given to exterior appearances of structures, signs and other improvements;*
- E. *Protect and enhance the City's appeal and thus support and stimulate business and industry and promote the desirability of investment and occupancy in business, commercial and industrial purposes;*

- F. *Stabilize and improve property values and prevent blighted areas and, thus, increase tax revenues;*
- G. *Insure that adequate public facilities are available to serve development as it occurs and that proper attention is given to site planning and development so as to not adversely impact the orderly, efficient and economic provision of public facilities and services.*
- H. *Achieve the beneficial influence of pleasant environments for living and working on behavioral patterns and, thus, decrease the cost of governmental services and reduce opportunities for crime through careful consideration of physical design and site layout under defensible space guidelines that clearly define all areas as either public, semi-private, or private, provide clear identity of structures and opportunities for easy surveillance of the site that maximize resident control of behavior -- particularly crime;*
- I. *Foster civic pride and community spirit so as to improve the quality and quantity of citizen participation in local government and in community growth, change and improvements;*
- J. *Sustain the comfort, health, tranquility and contentment of residents and attract new residents by reason of the City's favorable environment and, thus, to promote and protect the peace, health and welfare of the City.*

Response: The City Council adopted the Frog Pond West Master Plan to guide development in this area. The Master Plan addresses visual appeal, infrastructure provisions, and protection of the natural areas within the development site. The proposed development is intended to advance the vision for Frog Pond West by incorporating the natural areas on site, providing attractive streetscapes, and enhancing the existing neighborhood to the south and the future school and park to the west and north. The intent of this purpose statement is incorporated into the proposed site design.

Per City staff, the project elements subject to the standards of this section include tracts and their landscaping; landscaping in the public right-of-way; retaining walls; and public furnishings.

B. Section 4.421. Criteria and Application of Design Standards.

(.01) The following standards shall be utilized by the Board in reviewing the plans, drawings, sketches and other documents required for Site Design Review. These standards are intended to provide a frame of reference for the applicant in the development of site and building plans as well as a method of review for the Board. These standards shall not be regarded as inflexible requirements. They are not intended to discourage creativity, invention and innovation. The specifications of one or more particular architectural styles is not included in these standards. (Even in the Boones Ferry Overlay Zone, a range of architectural styles will be encouraged.)

- A. *Preservation of Landscape. The landscape shall be preserved in its natural state, insofar as practicable, by minimizing tree and soils removal, and any grade changes shall be in keeping with the general appearance of neighboring developed areas.*

Response: Tract E includes a mature grove of native trees including Oregon White Oak, Ponderosa and Scots Pine, Black Hawthorn, Fir and others. Tract D also includes many mature trees of similar varieties. Trees in both Tracts are to be preserved. The subject site's stormwater facilities are proposed in the lower elevation Tracts A and B to minimize necessary grading at the subject property. This standard is met.

- B. *Relation of Proposed Buildings to Environment. Proposed structures shall be located and designed to assure harmony with the natural environment, including protection of steep slopes, vegetation and other naturally sensitive areas for wildlife habitat and shall provide proper buffering from less intensive uses in accordance with Sections 4.171 and 4.139 and 4.139.5. The achievement of such relationship may include the enclosure of space in conjunction with other existing buildings or other proposed buildings and the creation of focal points with respect to avenues of approach, street access or relationships to natural features such as vegetation or topography.*

Response: Proposed Tract E consists of 68,470 sq. ft. of open space including a mature grove of native trees, to be protected. To encourage community-use as active open space, proposed structures in Tract E include a children's play structure and swing set on top of protective safety surfacing, a bench and another smaller play structure, and a 10-foot-wide concrete pedestrian path. Tract D consists of preserved, mature, native trees and no structures are proposed. See Sheets L2.00 and L2.10 for details. A 5-ft wide pathway branching out from the main path and connecting to the vehicle turnaround from Street E has been removed from the plans and is no longer proposed. Fences are proposed around the

stormwater ponds in Tracts A and B, as described above in this narrative. The fences are proposed to provide protection to the public. This standard is met.

C. Drives, Parking and Circulation. With respect to vehicular and pedestrian circulation, including walkways, interior drives and parking, special attention shall be given to location and number of access points, general interior circulation, separation of pedestrian and vehicular traffic, and arrangement of parking areas that are safe and convenient and, insofar as practicable, do not detract from the design of proposed buildings and structures and the neighboring properties.

Response: The drives, parking, and circulation within the development is subject to the requirements of the RN Zone, the Planned Development overlay, and Land Division requirements and are not subject to Site Design Review. This standard is not applicable.

D. Surface Water Drainage. Special attention shall be given to proper site surface drainage so that removal of surface waters will not adversely affect neighboring properties of the public storm drainage system.

Response: See Sheet P2.00 for the location of LIDA facilities within the planter strips of the public streets and Sheets P4.00 and L2.20 for the location of stormwater facilities within tracts. See Sheet L2.30 for details of LIDA facility planting; and see Appendix B for the Preliminary Drainage Report.

This standard is met.

E. Utility Service. Any utility installations above ground shall be located so as to have a harmonious relation to neighboring properties and site. The proposed method of sanitary and storm sewage disposal from all buildings shall be indicated.

Response: As shown on Sheet P4.00, each lot will be served by a sanitary sewer line. Storm sewage disposal is provided by a storm drain system connecting to each on-site stormwater facility. This standard is met.

F. Advertising Features. In addition to the requirements of the City's sign regulations, the following criteria should be included: the size, location, design, color, texture, lighting and materials of all exterior signs and outdoor advertising structures or features shall not detract from the design of proposed buildings and structures and the surrounding properties.

Response: No signs are proposed with this application. This standard is not applicable.

G. Special Features. Exposed storage areas, exposed machinery installations, surface areas, truck loading areas, utility buildings and structures and similar accessory areas and structures shall be subject to such setbacks, screen plantings or other screening methods as shall be required to prevent their being incongruous with the existing or contemplated environment and its surrounding properties. Standards for screening and buffering are contained in Section 4.176.

Response: The proposed development is a single-family residential development, and no storage areas, machinery installations, surface areas, truck loading areas, or utility buildings or structures are proposed. This standard is not applicable.

(.02) The standards of review outlined in Sections (a) through (g) above shall also apply to all accessory buildings, structures, exterior signs and other site features, however related to the major buildings or structures.

Response: No accessory buildings, signs, or other site features are proposed. Proposed structures are addressed above.

(.03) The Board shall also be guided by the purpose of Section 4.400, and such objectives shall serve as additional criteria and standards.

Response: The purpose of Section 4.400 is addressed earlier in this section. This standard is met.

(.04) *Conditional application. The Planning Director, Planning Commission, Development Review Board or City Council may, as a Condition of Approval for a zone change, subdivision, land partition, variance, conditional use, or other land use action, require conformance to the site development standards set forth in this Section.*

Response: This application includes a zone change and planned development, among other applications, and includes responses to the site development standards of those sections. Per City staff, the project elements subject to Site Design Review and the standards of this chapter are tracts and their landscaping, and landscaping in the public right-of-way.

(.05) *The Board may attach certain development or use conditions in granting an approval that are determined necessary to insure the proper and efficient functioning of the development, consistent with the intent of the Comprehensive Plan, allowed densities and the requirements of this Code. In making this determination of compliance and attaching conditions, the Board shall, however, consider the effects of this action on the availability and cost of needed housing. The provisions of this section shall not be used in such a manner that additional conditions either singularly or accumulatively have the effect of unnecessarily increasing the cost of housing or effectively excluding a needed housing type.*

Response: The development has been designed in accordance with the Frog Pond West Master Plan, which is part of, and consistent with, the Comprehensive Plan. The proposed development plan is consistent with the densities and other requirements established by the Frog Pond West Master Plan and the implementing RN zone. No additional conditions are needed to ensure that the development remains consistent with the City's adopted policies.

(.06) *The Board or Planning Director may require that certain paints or colors of materials be used in approving applications. Such requirements shall only be applied when site development or other land use applications are being reviewed by the City.*

- A. *Where the conditions of approval for a development permit specify that certain paints or colors of materials be used, the use of those paints or colors shall be binding upon the applicant. No Certificate of Occupancy shall be granted until compliance with such conditions has been verified.*
- B. *Subsequent changes to the color of a structure shall not be subject to City review unless the conditions of approval under which the original colors were set included a condition requiring a subsequent review before the colors could be changed.*

Response: The proposed development is detached single-family residential development. No paints or colors of materials are identified in the design standards of the Frog Pond West Master Plan. It is anticipated that building elevations, including paint and material colors, will be evaluated at the time of building permit review.

C. Section 4.440. Procedure.

(.01) Submission of Documents. *A prospective applicant for a building or other permit who is subject to site design review shall submit to the Planning Department, in addition to the requirements of Section 4.035, the following:*

- A. *A site plan, drawn to scale, showing the proposed layout of all structures and other improvements including, where appropriate, driveways, pedestrian walks, landscaped areas, fences, walls, off-street parking and loading areas, and railroad tracks. The site plan shall indicate the location of entrances and exits and direction of traffic flow into and out of off-street parking and loading areas, the location of each parking space and each loading berth and areas of turning and maneuvering vehicles. The site plan shall indicate how utility service and drainage are to be provided.*

Response: Sheet P2.00 shows the proposed layout of improvements, driveways, pedestrian walks, fences, and walls. Sheets L2.00 – L2.40 shows landscaped areas. Sheets L3.00 and L3.10 show the Stafford Road wall and monument sign.

- B. *A Landscape Plan, drawn to scale, showing the location and design of landscaped areas, the variety and sizes of trees and plant materials to be planted on the site, the location and design of landscaped areas, the varieties, by scientific and common name, and sizes of trees and plant materials to be retained or planted on the site, other pertinent landscape features, and irrigation systems required to maintain trees and plant materials. An inventory, drawn at the same scale as the Site Plan, of*

existing trees of 4" caliper or more is required. However, when large areas of trees are proposed to be retained undisturbed, only a survey identifying the location and size of all perimeter trees in the mass is necessary.

Response: Sheet L1.10 provides an inventory of existing trees. Sheets L2.00– L2.40 shows landscaped areas and landscape schedules and Sheet L3.20 shows planting details.

C. *Architectural drawings or sketches, drawn to scale, including floor plans, in sufficient detail to permit computation of yard requirements and showing all elevations of the proposed structures and other improvements as they will appear on completion of construction. Floor plans shall also be provided in sufficient detail to permit computation of yard requirements based on the relationship of indoor versus outdoor living area, and to evaluate the floor plan's effect on the exterior design of the building through the placement and configuration of windows and doors.*

Response: Example building elevations are included as Appendix H.

D. *A Color Board displaying specifications as to type, color, and texture of exterior surfaces of proposed structures. Also, a phased development schedule if the development is constructed in stages.*

E. *A sign Plan, drawn to scale, showing the location, size, design, material, color and methods of illumination of all exterior signs.*

F. *The required application fee.*

Response: A color board is not included, as exterior dwelling design will be evaluated at the time of building permit review. No signs are proposed at this time. The required application fee has been submitted with this application.

IX. Tree Preservation and Protection

A. Section 4.600.20. Applicability of Subchapter

(.01) The provisions of this subchapter apply to the United States and the State of Oregon, and to their agencies and subdivisions, including the City of Wilsonville, and to the employees and agents thereof.

(.02) By this subchapter, the City of Wilsonville regulates forest practices on all lands located within its urban growth boundary, as provided by ORS 527.722.

(.03) The provisions of this subchapter apply to all land within the City limits, including property designated as a Significant Resource Overlay Zone or other areas or trees designated as protected by the Comprehensive Plan, City zoning map, or any other law or ordinance; except that any tree activities in the Willamette River Greenway that are regulated by the provisions of WC 4.500 - 4.514 and requiring a conditional use permit shall be reviewed by the DRB under the application and review procedures set forth for Tree Removal Permits.

Response: Upon annexation and at the time of development, the site will be located within City limits and this subchapter will be applicable.

Section 4.600.30. Tree Removal Permit Required

(.01) Requirement Established. No person shall remove any tree without first obtaining a Tree Removal Permit (TRP) as required by this subchapter.

(.02) Tree Removal Permits will be reviewed according to the standards provided for in this subchapter, in addition to all other applicable requirements of Chapter 4.

(.03) Although tree activities in the Willamette River Greenway are governed by WC 4.500 - 4.514, the application materials required to apply for a conditional use shall be the same as those required for a Type B or C permit under this subchapter, along with any additional materials that may be required by the Planning Department. An application for a Tree Removal Permit under this section shall be reviewed by the Development Review Board.

Response: As shown on Sheet L1.00 and described in Appendix E, the development will remove trees and a Tree Removal Permit is required.

Section 4.600.40. Exceptions

(.01) Exception from requirement. Notwithstanding the requirement of WC 4.600.30(1), the following

activities are allowed without a Tree Removal Permit, unless otherwise prohibited:

- A. *Agriculture, Commercial Tree Farm or Orchard. Tree removal or transplanting occurring during use of land for commercial purposes for agriculture, orchard(s), or tree farm(s), such as Christmas tree production.*
- B. *Emergencies. Actions made necessary by an emergency, such as tornado, windstorm, flood, freeze, utility damage or other like disasters, in order to prevent imminent injury or damage to persons or property or restore order and it is impractical due to circumstances to apply for a permit.*
 - 1. *When an emergency has occurred, a Tree Removal Permit must be applied for within thirty (30) days following the emergency tree removal under the application procedures established in this subchapter.*
 - 2. *In addition to complying with the permit application requirements of this subchapter, an applicant shall provide a photograph of any tree removed and a brief description of the conditions that necessitated emergency removal. Such photograph shall be supplied within seven days of application for a permit. Based on good cause shown arising out of the emergency, the Planning Director may waive any or all requirements of this section.*
 - 3. *Where a Type A Permit is granted for emergency tree removal, the permittee is encouraged to apply to the City Tree Fund for replanting assistance.*
- C. *City utility or road work in utility or road easements, in utility or road rights-of-way, or in public lands. However, any trees removed in the course of utility work shall be mitigated in accordance with the standards of this subchapter.*
- D. *Nuisance abatement. The City is not required to apply for a Tree Removal Permit to undertake nuisance abatement as provided in WC 6.200 et seq. However, the owner of the property subject to nuisance abatement is subject to all the provisions of this subchapter in addition to the requirements of WC 6.200 et seq.*
- E. *The removal of filbert trees is exempt from the requirements of this subchapter.*
- F. *The Charbonneau District, including its golf course, is exempt from the requirements of WC 4.600.30(1) on the basis that by and through the current CC&R's of the Charbonneau Country Club, the homeowners' association complies with all requirements of WC 4.610.30(1)(C)(1). This exception has been based upon the Tree Maintenance and Protection Plan that has been submitted by the Charbonneau Country Club and approved by the Planning Director. Tree removal activities remain subject to all applicable standards of this subchapter. Unless authorized by the City, this exception does not include tree removal upon any public easements or public property within the district. In the event that the CC&R's are changed relative to the effect of the Tree Maintenance and Protection Plan, then the Planning Director shall review whether such effect is material, whether it can be mitigated, and if not, may disallow the exemption.*

Response: The proposed tree removal is not listed as exempt. The provisions of this chapter are applicable.

Section 4.600.50. Application For Tree Removal Permit

(.01) Application for Permit. *A person seeking to remove one or more trees shall apply to the Director for a Tree Removal Permit for a Type A, B, C, or D permit, depending on the applicable standards as provided in this subchapter.*

- A. *An application for a tree removal permit that does not meet the requirements of Type A may be submitted as a Type B application.*

(.02) Time of Application. *Application for a Tree Removal Permit shall be made before removing or transplanting trees, except in emergency situations as provided in WC 4.600.40 (1)(B) above. Where the site is proposed for development necessitating site plan or plat review, application for a Tree Removal Permit shall be made as part of the site development application as specified in this subchapter.*

(.03) Fees. *A person applying for a Tree Removal Permit shall pay a non-refundable application fee; as established by resolution of the City Council.*

- A. *By submission of an application, the applicant shall be deemed to have authorized City representatives to have access to applicant's property as may be needed to verify the information provided, to observe site conditions, and if a permit is granted, to verify that terms and conditions of the permit are followed.*

Response: The site is proposed for development necessitating site plan and plat review, and this application includes a request for a Type C Tree Removal Permit. The application fee has been submitted with this application.

B. Section 4.610.00. Application Review Procedure

(.01) The permit applicant shall provide complete information as required by this subchapter in order for the City to review the application.

*(.02) **Departmental Review.** All applications for Tree Removal Permits must be deemed complete by the City Planning Department before being accepted for review. When all required information has been supplied, the Planning Department will verify whether the application is complete. Upon request of either the applicant or the City, the City may conduct a field inspection or review meeting. City departments involved in the review shall submit their report and recommendations to the Planning Director who shall forward them to the appropriate reviewing authority.*

*(.03) **Reviewing Authority.***

- A. Type A or B. Where site plan review or plat approval by the Development Review Board is not required by City ordinance, the grant or denial of the Tree Removal Permit application shall be the responsibility of the Planning Director. The Planning Director has the authority to refer a Type B permit application to the DRB under the Class II administrative review procedures of this Chapter. The decision to grant or deny a permit shall be governed by the applicable review standards enumerated in WC 4.610.10*
- B. Type C. Where the site is proposed for development necessitating site plan review or plat approval by the Development Review Board, the Development Review Board shall be responsible for granting or denying the application for a Tree Removal Permit, and that decision may be subject to affirmance, reversal or modification by the City Council, if subsequently reviewed by the Council.*
- C. Type D. Type D permit applications shall be subject to the standards and procedures of Class I administrative review and shall be reviewed for compliance with the Oregon Forest Practice Rules and Statutes. The Planning Director shall make the decision to grant or deny an application for a Type D permit.*
- D. Review period for complete applications. Type A permit applications shall be reviewed within 10 (ten) working days. Type B permit applications shall be reviewed by the Planning Director within thirty (30) calendar days, except that the DRB shall review any referred application within sixty (60) calendar days. Type C permit applications shall be reviewed within the time frame established by this Chapter. Type D permit applications shall be reviewed within 15 calendar days.*

Response: The application is for a Type C Tree Removal Permit and is subject to review and approval by the DRB.

[...]

Section 4.610.10. Standards For Tree Removal, Relocation Or Replacement

(.01) Except where an application is exempt, or where otherwise noted, the following standards shall govern the review of an application for a Type A, B, C or D Tree Removal Permit:

- A. Standard for the Significant Resource Overlay Zone. The standard for tree removal in the Significant Resource Overlay Zone shall be that removal or transplanting of any tree is not inconsistent with the purposes of this Chapter.*

Response: The site does not contain SROZ area. The standard is not applicable.

- B. Preservation and Conservation. No development application shall be denied solely because trees grow on the site. Nevertheless, tree preservation and conservation as a design principle shall be equal in concern and importance to other design principles.*

Response: As shown on Sheet L1.00, many of the trees to be removed are located within the grading limits of SW Frog Pond Lane, Larkspur Terr., and proposed Street E. The remainder of the trees to be removed are located within the building footprint of the individual lots, as determined by minimum setbacks and driveway depth requirements. The applicant has made significant efforts to preserve most existing trees on the subject property with the proposed open space Tracts D and E. Of the 104 trees on the subject site 76 trees (73 percent) are to be preserved.

- C. Developmental Alternatives. Preservation and conservation of wooded areas and trees shall be given careful consideration when there are feasible and reasonable location alternatives and design options on-site for proposed buildings, structures or other site improvements.*

Response: The Frog Pond West Master Plan provides clear direction for street connections and residential densities. The applicant proposed Willow Creek Drive to track westerly on the northern portion of the subject property to avoid the grove of mature native trees in Tract E. The trees within the Tracts E and D will be preserved. This standard is met.

D. Land Clearing. Where the proposed activity requires land clearing, the clearing shall be limited to designated street rights-of-way and areas necessary for the construction of buildings, structures or other site improvements.

Response: The proposed land clearing is limited to designated street rights-of-way and areas necessary for the construction of single-family homes. This standard is met.

E. Residential Development. Where the proposed activity involves residential development, residential units shall, to the extent reasonably feasible, be designed and constructed to blend into the natural setting of the landscape.

Response: The proposed development is a single-family residential development. The units will be designed and constructed, as much as possible, to blend into the natural areas on the site. This standard is met.

F. Compliance With Statutes and Ordinances. The proposed activity shall comply with all applicable statutes and ordinances.

Response: Applicable statutes and ordinances include the City's Development Code. The proposed activity will comply with this code and any other applicable statutes and ordinances. This standard is met.

G. Relocation or Replacement. The proposed activity shall include necessary provisions for tree relocation or replacement, in accordance with WC 4.620.00, and the protection of those trees that are not to be removed, in accordance with WC 4.620.10.

Response: As shown in Sheet L1.00 and described in Appendix E, trees to be retained will be protected per the provisions of 4.620.10 and trees will be replaced in accordance with 4.620.00. Those provisions are addressed in the responses to Section 4.620.00 below in this narrative. This standard is met.

H. Limitation. Tree removal or transplanting shall be limited to instances where the applicant has provided completed information as required by this Chapter and the reviewing authority determines that removal or transplanting is necessary based on the criteria of this subsection.

1. Necessary For Construction. Where the applicant has shown to the satisfaction of the reviewing authority that removal or transplanting is necessary for the construction of a building, structure or other site improvement, and that there is no feasible and reasonable location alternative or design option on-site for a proposed building, structure or other site improvement; or a tree is located too close to existing or proposed buildings or structures, or creates unsafe vision clearance.

Response: Per the arborist's report included as Appendix E, there are 104 trees on site. Seventy-six (76) of the trees are identified for protection on site. In total, 38 trees will be removed from the site.

Removal of the trees on site is necessary for construction of site improvements, including utilities, streets, and detached residential dwellings. The location of streets and connections was determined by the Frog Pond West Master Plan and the block perimeter requirements of the RN zone. In addition, the designation of the site as a single-family area requires the grading of each lot to accommodate single-family dwellings and associated site improvements (driveways and walkways, stormwater management, outdoor yard areas, etc.). Reducing building footprints by increasing height is not a viable alternative as the height limit in the RN zone is 35 ft., or 2.5 stories.

This standard is met.

2. Disease, Damage, or Nuisance, or Hazard. Where the tree is diseased, damaged, or in danger of falling, or presents a hazard as defined in WC 6.208, or is a nuisance as defined in WC 6.200 et seq., or creates unsafe vision clearance as defined in this Code.

- (a) *As a condition of approval of Stage II development, filbert trees must be removed if they are no longer commercially grown or maintained.*

Response: No filbert trees were identified. This standard is not applicable.

3. *Interference. Where the tree interferes with the healthy growth of other trees, existing utility service or drainage, or utility work in a previously dedicated right-of-way, and it is not feasible to preserve the tree on site.*

Response: As shown on Sheet L1.00, several of the trees proposed for removal are located within the SW Frog Pond Lane, SW Larkspur Terr., and future Street E rights-of-way to be dedicated with the plat. The construction of these streets and associated sidewalks and utilities requires their removal. These trees cannot be preserved while providing the street network required by the Frog Pond West Master Plan and established by previous approvals.

4. *Other. Where the applicant shows that tree removal or transplanting is reasonable under the circumstances.*

Response: The proposed development is anticipated by the Frog Pond West Master Plan. While the development requires removal of trees on site, the trees removed will be mitigated, and street trees appropriate for the size and location of the planter strips within the public right-of-way will be planted. These trees will serve to soften the urban environment, contribute to stormwater management, and provide shade and protection for pedestrians.

I. *Additional Standards for Type C Permits.*

1. *Tree survey. For all site development applications reviewed under the provisions of Chapter 4 Planning and Zoning, the developer shall provide a Tree Survey before site development as required by WC 4.610.40, and provide a Tree Maintenance and Protection plan, unless specifically exempted by the Planning Director or DRB, prior to initiating site development.*

Response: A tree survey has been completed and incorporated into the Tree Removal and Protection Plan included as Sheet L1.00 and L1.10. This standard is met.

2. *Platted Subdivisions. The recording of a final subdivision plat whose preliminary plat has been reviewed and approved after the effective date of Ordinance 464 by the City and that conforms with this subchapter shall include a Tree Survey and Maintenance and Protection Plan, as required by this subchapter, along with all other conditions of approval.*

Response: A tree survey has been completed and incorporated into the Tree Removal and Protection Plan included as Sheets L1.00 and L1.10. This standard is met.

3. *Utilities. The City Engineer shall cause utilities to be located and placed wherever reasonably possible to avoid adverse environmental consequences given the circumstances of existing locations, costs of placement and extensions, the public welfare, terrain, and preservation of natural resources. Mitigation and/or replacement of any removed trees shall be in accordance with the standards of this subchapter.*

Response: The utilities will be located and placed within rights-of-way or adjacent PUEs whenever possible. Trees removed from the site will be mitigated and/or replaced per the provisions of 4.620.00. This standard is met.

[...]

Section 4.610.40. Type C Permit

(.01) *Approval to remove any trees on property as part of a site development application may be granted in a Type C permit. A Type C permit application shall be reviewed by the standards of this subchapter and all applicable review criteria of Chapter 4. Application of the standards of this section shall not result in a reduction of square footage or loss of density, but may require an applicant to modify plans to allow for buildings of greater height. If an applicant proposes to remove trees and submits a landscaping plan as part of a site development application, an application for a Tree Removal Permit shall be included. The Tree Removal Permit application will be reviewed in the Stage II development review*

process, and any plan changes made that affect trees after Stage II review of a development application shall be subject to review by DRB. Where mitigation is required for tree removal, such mitigation may be considered as part of the landscaping requirements as set forth in this Chapter. Tree removal shall not commence until approval of the required Stage II application and the expiration of the appeal period following that decision. If a decision approving a Type C permit is appealed, no trees shall be removed until the appeal has been settled.

Response: The proposed development requires removal of trees; a landscaping plan has been submitted as part of the site development application, and the application includes a request for a Tree Removal Permit. Mitigation is required and addressed in the responses to Section 4.620.00.

(.02) *The applicant must provide ten copies of a Tree Maintenance and Protection Plan completed by an arborist that contains the following information:*

- A. *A plan, including a topographical survey bearing the stamp and signature of a qualified, registered professional containing all the following information:*
1. *Property Dimensions. The shape and dimensions of the property, and the location of any existing and proposed structure or improvement.*

Response: See Sheets P1.00 and P1.10 Existing Conditions for the location of existing structures and improvements; See Sheet P2.00 Preliminary Site Plan for the location of proposed improvements.

2. *Tree survey. The survey must include:*

- a. *An accurate drawing of the site based on accurate survey techniques at a minimum scale of one inch (1") equals one hundred feet (100') and which provides a) the location of all trees having six inches (6") or greater d.b.h. likely to be impacted, b) the spread of canopy of those trees, (c) the common and botanical name of those trees, and d) the approximate location and name of any other trees on the property.*
- b. *A description of the health and condition of all trees likely to be impacted on the site property. In addition, for trees in a present or proposed public street or road right-of-way that are described as unhealthy, the description shall include recommended actions to restore such trees to full health. Trees proposed to remain, to be transplanted or to be removed shall be so designated. All trees to remain on the site are to be designated with metal tags that are to remain in place throughout the development. Those tags shall be numbered, with the numbers keyed to the tree survey map that is provided with the application.*
- c. *Where a stand of twenty (20) or more contiguous trees exist on a site and the applicant does not propose to remove any of those trees, the required tree survey may be simplified to accurately show only the perimeter area of that stand of trees, including its drip line. Only those trees on the perimeter of the stand shall be tagged, as provided in "b," above.*
- d. *All Oregon white oaks, native yews, and any species listed by either the state or federal government as rare or endangered shall be shown in the tree survey.*

Response: See Sheets L1.00 and L1.10 for a tree survey indicating the location of trees greater than 6-in DBH, and their botanical names. See Appendix E Tree Plan and Sheet L1.10 for information about the condition of the trees, crown diameter, and proposed action for each tree. Thirty-two (32) Oregon white oak trees were identified on the site and are shown on the tree survey.

3. *Tree Protection. A statement describing how trees intended to remain will be protected during development, and where protective barriers are necessary, that they will be erected before work starts. Barriers shall be sufficiently substantial to withstand nearby construction activities. Plastic tape or similar forms of markers do not constitute "barriers."*

Response: See Appendix E, Page 1, for a description of activities permitted and prohibited within the root protection zone of trees to be protected. See also the Tree Protection Detail and note on Sheet L1.00.

4. *Easements and Setbacks. Location and dimension of existing and proposed easements, as well as all setbacks required by existing zoning requirements.*

Response: See Sheet P2.00 Preliminary Site Plan for setbacks required by zoning requirements. See Sheet P3.00 for the location and dimensions of proposed easements.

5. *Grade Changes.* Designation of grade changes proposed for the property that may impact trees.

Response: Sheet L1.00 Tree Removal and Protection Plan includes proposed grading contours.

6. *Cost of Replacement.* A cost estimate for the proposed tree replacement program with a detailed explanation including the number, size and species.

Response: No payment into the tree replacement fund is proposed.

7. *Tree Identification.* A statement that all trees being retained will be identified by numbered metal tags, as specified in subsection "A," above in addition to clear identification on construction documents.

Response: The Tree Plan Legend on Sheet L1.00 includes a statement identifying the purpose of the tree tags.

C. Section 4.620.00. Tree Relocation, Mitigation, Or Replacement

(.01) Requirement Established. A Type B or C Tree Removal Permit grantee shall replace or relocate each removed tree having six (6) inches or greater d.b.h. within one year of removal.

(.02) Basis For Determining Replacement. The permit grantee shall replace removed trees on a basis of one (1) tree replanted for each tree removed. All replacement trees must measure two inches (2") or more in diameter. Alternatively, the Planning Director or Development Review Board may require the permit grantee to replace removed trees on a per caliper inch basis, based on a finding that the large size of the trees being removed justifies an increase in the replacement trees required. Except, however, that the Planning Director or Development Review Board may allow the use of replacement Oregon white oaks and other uniquely valuable trees with a smaller diameter.

Response: The proposed tree removal requires replacement of each tree having 6 inches or greater dbh within one year of removal. As noted in Sheet L1.10, 38 trees of 6 inches or greater dbh are proposed for removal. The standard is met.

(.03) Replacement Tree Requirements. A mitigation or replacement tree plan shall be reviewed by the City prior to planting and according to the standards of this subsection.

- A. Replacement trees shall have shade potential or other characteristics comparable to the removed trees, shall be appropriately chosen for the site from an approved tree species list supplied by the City, and shall be state Department of Agriculture Nursery Grade No. 1 or better.
- B. Replacement trees must be staked, fertilized and mulched, and shall be guaranteed by the permit grantee or the grantee's successors-in-interest for two (2) years after the planting date.
- C. A "guaranteed" tree that dies or becomes diseased during that time shall be replaced.
- D. Diversity of tree species shall be encouraged where trees will be replaced, and diversity of species shall also be maintained where essential to preserving a wooded area or habitat.

Response: There are 50 replacement trees proposed to be provided as street trees. The replacement street trees have been selected from the City's street tree list. Replacement trees will be maintained and replaced if they die within the two-year establishment period.

(.04) All trees to be planted shall consist of nursery stock that meets requirements of the American Association of Nurserymen (AAN) American Standards for Nursery Stock (ANSI Z60.1) for top grade.

(.05) Replacement Tree Location.

- A. *City Review Required.* The City shall review tree relocation or replacement plans in order to provide optimum enhancement, preservation and protection of wooded areas. To the extent feasible and desirable, trees shall be relocated or replaced on-site and within the same general area as trees removed.
- B. *Relocation or Replacement Off-Site.* When it is not feasible or desirable to relocate or replace trees on-site, relocation or replacement may be made at another location approved by the City.

Response: The tree replacement plan/landscaping plan is included as Sheet L2.00. Replacement trees consist of street trees. Trees will likely be planted on the individual dwelling lots at the time of site development but are not proposed to be included in the replacement tree plans. The standard is met.

(.06) City Tree Fund. Where it is not feasible to relocate or replace trees on site or at another

approved location in the City, the Tree Removal Permit grantee shall pay into the City Tree Fund, which fund is hereby created, an amount of money approximately the value as defined by this subchapter, of the replacement trees that would otherwise be required by this subchapter. The City shall use the City Tree Fund for the purpose of producing, maintaining and preserving wooded areas and heritage trees, and for planting trees within the City.

- A. The City Tree Fund shall be used to offer trees at low cost on a first-come, first-serve basis to any Type A Permit grantee who requests a tree and registers with the City Tree Fund.
- B. In addition, and as funds allow, the City Tree Fund shall provide educational materials to assist with tree planting, mitigation, and relocation.

Response: There are 50 street trees proposed on site. This exceeds the 38 trees required for replacement. Payment into the City Tree Fund is not requested.

(.07) Exception. Tree replacement may not be required for applicants in circumstances where the Director determines that there is good cause to not so require. Good cause shall be based on a consideration of preservation of natural resources, including preservation of mature trees and diversity of ages of trees. Other criteria shall include consideration of terrain, difficulty of replacement and impact on adjacent property.

Response: The applicant is not requesting an exception to the tree replacement requirement.

Section 4.620.10. Tree Protection During Construction

(.01) Where tree protection is required by a condition of development under Chapter 4 or by a Tree Maintenance and Protection Plan approved under this subchapter, the following standards apply:

- A. All trees required to be protected must be clearly labeled as such.
- B. *Placing Construction Materials Near Tree.* No person may conduct any construction activity likely to be injurious to a tree designated to remain, including, but not limited to, placing solvents, building material, construction equipment, or depositing soil, or placing irrigated landscaping, within the drip line, unless a plan for such construction activity has been approved by the Planning Director or Development Review Board based upon the recommendations of an arborist.
- C. *Attachments to Trees During Construction.* Notwithstanding the requirement of WC 4.620.10(1)(A), no person shall attach any device or wire to any protected tree unless needed for tree protection.
- D. *Protective Barrier.* Before development, land clearing, filling or any land alteration for which a Tree Removal Permit is required, the developer shall erect and maintain suitable barriers as identified by an arborist to protect remaining trees. Protective barriers shall remain in place until the City authorizes their removal or issues a final certificate of occupancy, whichever occurs first. Barriers shall be sufficiently substantial to withstand nearby construction activities. Plastic tape or similar forms of markers do not constitute "barriers." The most appropriate and protective barrier shall be utilized. Barriers are required for all trees designated to remain, except in the following cases:
 - 1. *Right-of-Ways and Easements.* Street right-of-way and utility easements may be cordoned by placing stakes a minimum of fifty (50) feet apart and tying ribbon, plastic tape, rope, etc., from stake to stake along the outside perimeters of areas to be cleared.
 - 2. Any property area separate from the construction or land clearing area onto which no equipment will venture may also be cordoned off as described in paragraph (D) of this subsection, or by other reasonable means as approved by the reviewing authority.

Response: Sheet L1.00 and the Arborist Report included as Appendix E provide direction regarding the protection of trees on the site, including compliance with this section. This standard is met.

X. Annexations and Urban Growth Boundary Amendments

A. Section 4.700. Procedures Relating To The Processing Of Requests For Annexation And Urban Growth Boundary Amendments.

(.01) The City of Wilsonville is located within the Portland Metropolitan Area, and is therefore subject to regional government requirements affecting changes to the city limits and changes to the Urban Growth Boundary (UGB) around Wilsonville. The City has the authority to annex properties as prescribed in State law, but the City's role in determining the UGB is primarily advisory to Metro, as provided in Oregon Revised Statutes. The following procedures will be used to aid the City Council in formulating recommendations to those regional entities. [Amended by Ordinance No. 538, 2/21/02.]

A. *Proponents of such changes shall provide the Planning Director with all necessary maps and written information to allow for review by city decision-makers. The Planning Director, after consultation with the City Attorney, will determine whether each given request is quasi-judicial or legislative in nature and will make the necessary arrangements for review based upon that determination.*

Response: The applicant has provided the required information. The Planning Director has determined that the annexation request is subject to quasi-judicial review.

B. *Written information submitted with each request shall include an analysis of the relationship between the proposal and the City's Comprehensive Plan, applicable statutes, as well as the Statewide Planning Goals and any officially adopted regional plan that may be applicable.*

Response: See Section III of this narrative for a discussion of the relationship between the proposed annexation and the City's Comprehensive Plan.

XI. Conclusion

The request for the Frog Pond Oaks development and related approvals has been shown to be consistent with the applicable standards of the City of Wilsonville. West Hills Land Development LLC respectfully requests approval of the applications.

Appendix A

City of Wilsonville Annexation Petitions and Certifications



CERTIFICATION OF LEGAL DESCRIPTION AND MAP

I hereby certify that the description of the property included within the attached petition (located on Assessor's Map 31W12D) has been checked by me and it is a true and exact description of the property under consideration, and the description corresponds to the attached map indicating the property under consideration.



NAME Carlton Smith
TITLE GIS Cartographer 3
DEPARTMENT Tax Assessors Office
COUNTY OF Clackamas
DATE: 11/9/2021

EXHIBIT A
LEGAL DESCRIPTION
FROG POND OAKS ANNEXATION

October 5, 2021 (Otak #20141)

That property described in Quitclaim Deed to Sheri L. Miller recorded June 1, 2017 as Document No. 2017-036685, Clackamas County Records, in the southeast quarter of Section 12, Township 3 South, Range 1 West, Willamette Meridian, Clackamas County, Oregon, further described as follows:

BEGINNING at the southeast corner of said Miller property from which a 5/8 inch iron rod with no cap was found bearing North 01°39'46" East a distance of 0.11 feet, said POINT OF BEGINNING also being a point on the north right of way line of S.W. Frog Pond Lane, North 01°40'13" East a distance of 1748.96 feet and North 88°35'30" West a distance of 537.57 feet from the southeast corner of said Section 12;

thence along the west lines of those properties described in Special Warranty Deed to Paul C. and Janene C. Chaney recorded January 16, 2001 as Document No. 2001-002679, and in Deed to Andrew J. Paris, Jr. et ux recorded April 5, 1972 as Document No. 72-002195, both of Clackamas County Records, North 01°39'46" East a distance of 898.20 feet to a point on the south line of Parcel II of Partition Plat No. 1991-43;

thence along said south line of Parcel II, North 88°46'45" West a distance of 507.70 feet to the northeast corner of that property described in Statutory Warranty Deed to Darrell R. and Sandi L. Lauer recorded June 13, 2018 as Document No. 2018-036152, Clackamas County Records;

thence along the east line of said Lauer property, South 01°40'13" West a distance of 896.54 feet to a point on said north right of way line;

thence along said north right of way line, South 88°35'30" East a distance of 507.81 feet to the POINT OF BEGINNING.

Contains 10.46 acres, more or less.

REGISTERED
PROFESSIONAL
LAND SURVEYOR

DIGITALLY SIGNED
2021.10.05 20:57:43-07'00'

OREGON
NOVEMBER 12, 2013
MICHAEL D. SPELTS
87475PLS

RENEWS: JUNE 30, 2022

PARCEL II, PARTITION PLAT NO. 1991-43

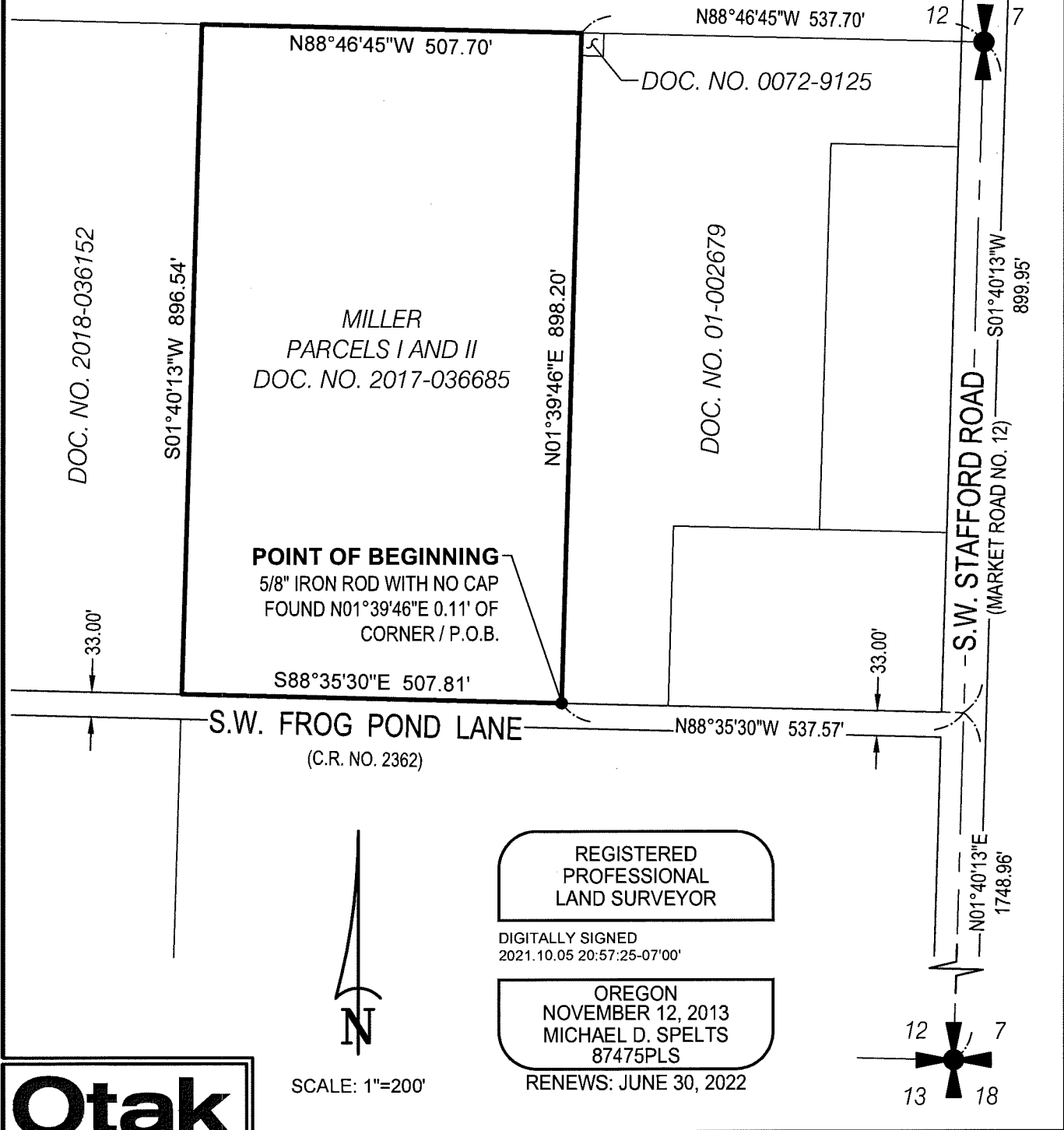

Otak

 808 SW 3rd Ave., Ste. 800
 Portland, Oregon 97204
 Phone: (503) 287-6825
 www.otak.com
 project: 20141

EXHIBIT A PAGE 2 OF 2

FROG POND OAKS ANNEXATION AREA
 IN THE SOUTHEAST QUARTER, SECTION 12, TOWNSHIP 3 SOUTH,
 RANGE 1 WEST, WILLAMETTE MERIDIAN
 CITY OF WILSONVILLE, CLACKAMAS COUNTY, OREGON

OCTOBER 5, 2021

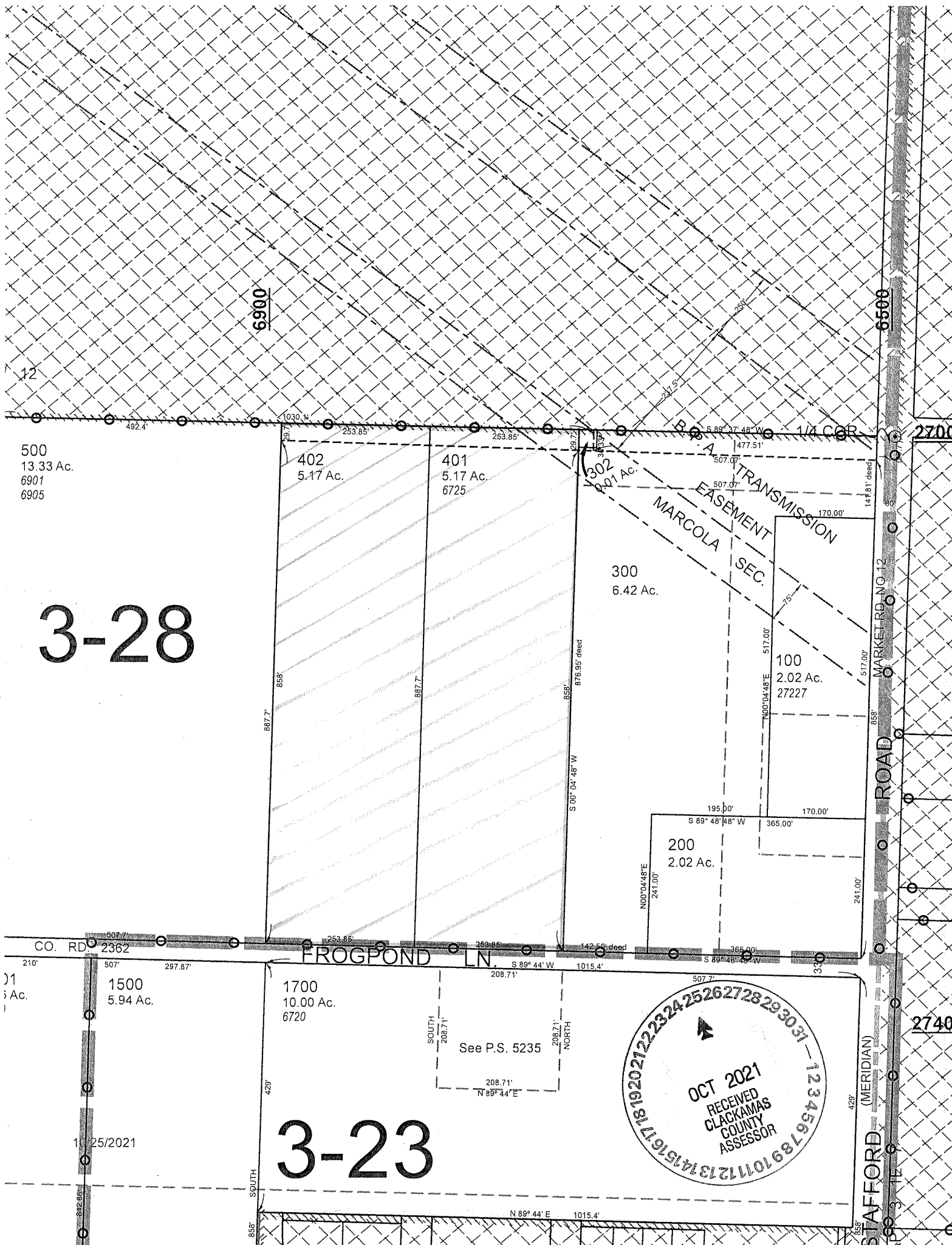

500
13.33 Ac.
6901
6905

3-28

01
Ac.
1500
5.94 Ac.

10/25/2021

1700
10.00 Ac.
6720

3-23

SOUTH
208.71'
See P.S. 5235
208.71'
NORTH
208.71'
N 89° 44' E
208.71'

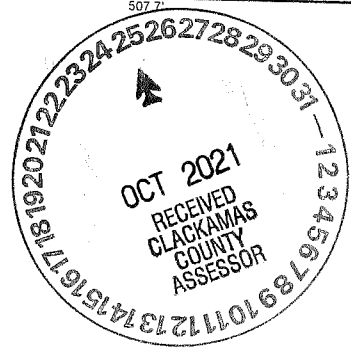

STAFFORD (MERIDIAN)

27401

**CERTIFICATION OF PROPERTY OWNERSHIP OF
100% OF LAND AREA**

I hereby certify that the attached petition contains the names of the owners¹ (as shown on the last available complete assessment roll) of 100% of the land area of the territory proposed for annexation as described in the attached petition.

NAME JOSHUA BOLL
TITLE GIS CARTOGRAPHER II
DEPARTMENT ASSESSMENT
COUNTY OF CLACKAMAS
DATE 10/25/21



¹ Owner means the legal owner of record or, where there is a recorded land contract which is in force, the purchaser thereunder. If a parcel of land has multiple owners, each consenting owner shall be counted as a percentage of their ownership interest in the land. That same percentage shall be applied to the parcel's land mass and assessed value for purposes of the consent petition. If a corporation owns land in territory proposed to be annexed, the corporation shall be considered the individual owner of that land.

CERTIFICATION OF REGISTERED VOTERS

I hereby certify that the attached petition contains the names of at least 50% of the electors registered in the territory proposed for annexation as described in the attached petition.





NAME Tiffany Clark
TITLE deputy clerk
DEPARTMENT Clackamas County Elections
COUNTY OF Clackamas
DATE December 6, 2021



Metro District Annexation

Annexation Petition For Property Owners





We the undersigned owner(s) of property described below and or elector(s) residing at the referenced location hereby petition for and give consent to, annexation of said property to the Metro District. We understand that the Metro Council will review this request in accordance with Chapter 3.09 of the Metro Code and the Oregon Revised Statutes to determine whether to approve or deny this request.

Signature	Printed Name	I am a		Property Description			Date	
		PO	RV	OV	Township/Range & Section Map Number	Tax lot		Precinct Number
	Sheri Miller			X		31W12D 6725 SW Frog Pond Ln	401 323	
	Jamie Mehus	X					402	
	Jeremiah Kreilich			X				
	Brian Powell			X				

PO: Property Owner, RV: Registered Voter, OV: Property Owner and Registered Voter

PETITION SIGNERS

NOTE: This petition may be signed by qualified persons even though they may not know their property description or precinct.

SIGNATURE	PRINTED NAME	I AM A: *			PROPERTY ADDRESS	LOT #	1/4 SEC	PROPERTY DESCRIPTION	
		PO	RV	OV				T	R
	Sheri Miller			X	6/25 SW Frog Pond Ln, Wilsonville OR	401	31	W	12D
	Jamie Mehus	X							
	Jeremiah Kreilich		X						
	Brian Powell		X						

* PO = Property Owner
 RV = Registered Voter
 OV = Owner And Registered Voter

Appendix B
Stormwater Preliminary Drainage Report dated
February 2022, by Otak, Inc.





Frog Pond Oaks
Preliminary Storm Drainage Report
Land Use

Submitted to:

City of Wilsonville
29799 SW Town Center Loop E.
Wilsonville, OR 97070

February 2022

Prepared by:

Otak, Inc.
808 SW Third Avenue, Suite 800
Portland, OR 97204

Project No. 20141

Acknowledgements

Project Name: Frog Pond Oaks
Type of Report: Preliminary
Submittal Level: Land Use

Submitted to

Project Manager: Keith Buisman, PE

Site Information

Subject Property: Miller
Applicant Information: Dan Grimberg
West Hills Land Development
3330 NW Yeon St. Suite 200
Portland, OR 97210
503-789-0358

Project Development Team

Stormwater Lead: Rose Horton, PE
Stormwater Designer: Roger Tiffany, EIT

TABLE OF CONTENTS

	Page
Section 1. Introduction	1
Section 2. Project Description	1
Permitting.....	2
Existing Conditions	2
Proposed Conditions	2
Section 3. Hydrology	2
Rainfall Depth	2
Pollutants of Concern	2
Wetlands.....	3
Soils	3
Flood Hazard	3
Section 4. Methodology.....	3
BMP Sizing Tool Hydrology	4
Drainage	4
Conveyance.....	4
Section 5. Water Quality Treatment	5
Low Impact Development	5
Water Quality Facilities	5
Section 6. Flow Control	5
Section 7. Operations and Maintenance	6
Section 8. Conclusion	6
Section 9. References	6

TABLES

Table 1	24 Hour Precipitation Depths	2
Table 2	Pollutants of Concern	3
Table 3	Facility Summary Table.....	5

FIGURES

Figure 1	Frog Pond Oaks – Existing Conditions
Figure 2	Frog Pond Oaks – Proposed Conditions

APPENDICES

Appendix A	Hydrology
Appendix B	Geotechnical Report
Appendix C	Downstream Analysis
Appendix D	BMP Sizing Tool Output
Appendix E	Operations and Maintenance Plans

Section 1. Introduction

The Frog Pond Oaks site is a proposed residential development located within the West Neighborhood of the Frog Pond Area Plan. The 10.34-acre property is comprised of Tax map 31W12D lots 401 and 402 in Clackamas County within the City of Wilsonville Urban Growth Boundary (UGB) (see Vicinity Map). The Frog Pond Oaks development will consist of 41 single-family residential dwellings as well as associated public infrastructure improvements including SW Frog Pond Lane, resulting in a 5.31-acre in new impervious surface area.

The purpose of this document is to demonstrate compliance of the Frog Pond Oaks stormwater management system with the City of Wilsonville Stormwater and Surface Water Design and Construction Standards (2015). Descriptions of the existing and proposed hydrologic conditions, as well as documentation showing compliance of the proposed onsite stormwater management system with City of Wilsonville standards for water quality and quantity are included in this report.



Section 2. Project Description

The Frog Pond Oaks proposed residential development consists of 41 new single-family lots, local street extensions, as well as sidewalks, public roadway improvements, utilities, and stormwater management systems that discharge to Willow Creek. Additionally, this project will include frontage improvements to SW Frog Pond Lane and SW Willow Creek Drive.

Permitting

The following permit applications will be required for this project:

- City of Wilsonville Development Permit
- Section 401 water quality certification from DEQ
- NPDES 1200C Permit
- Wetland Removal and/or Fill from DSL

Existing Conditions

The project site, shown in Figure 1 (attached), is primarily agricultural with a home and outbuildings that comprise 0.35 areas of impervious area. Most of the project site (8.14 acres) slopes south at about 2% towards Willow Creek while 2.54 acres slopes at about 3% towards the Boeckman Creek drainage to the northwest.

Proposed Conditions

Site improvements will include construction of approximately 5.31 acres of new impervious surfaces in the form of roof, roadway, and sidewalk area. Vegetated stormwater facilities to are proposed to be constructed within the right-of-way and tracts to provide low impact development water quality treatment and flow control throughout the proposed residential development.

The northern lots and right of ways will be conveyed to a rain garden in the southwest corner of the site. The southern lots and right-of-way will be conveyed to a rain garden in the southeast corner of the site. Runoff from SW Willow Creek Drive and SW Frog Pond Lane will shed to vegetated swales. Partial runoff from Street D and Street C will shed to vegetated swales. An undeveloped area of approximately 1.71 acres located at the northwest corner of the site will continue to drain towards Boeckman Creek (Figure 2).

Section 3. Hydrology

Rainfall Depth

The following rainfall depths listed in Table 1 are provided in the City of Wilsonville Public Works Standards (2015). These depths correspond to design recurrence intervals which are used in hydrologic calculations for various aspects of stormwater management design.

Table 1 24 Hour Precipitation Depths

Recurrence Interval (Years)	Total Precipitation Depth (inches)
2	2.50
10	3.45
25	3.90
100	4.50

Pollutants of Concern

The pollutants of concern are those typically found in roadway runoff. These include sediment, oil and grease, polycyclic aromatic hydrocarbons (PAHs), metals such as Copper, Zinc, and Lead as well as pesticides and other nutrients (DEQ, 2016). Table 2 lists each waterway affected by this project and DEQ listing status.

Table 2 Pollutants of Concern

Waterway	Parameter	Listing Status
Willow Creek	N/A	None
Boeckman Creek	N/A	None
Willamette River (Middle)	Chlorophyll a	303(d), TMDL needed
Willamette River (Middle)	E. Coli	TMDL approved
Willamette River (Middle)	Mercury	303(d), TMDL needed
Willamette River (Middle)	Temperature	TMDL approved

Wetlands

An isolated palustrine emergent wetland exists on site and will be impacted. This wetland was found to be non-jurisdictional. Discussion of the impacts to sensitive areas are provided by the environmental consultant, AKS Engineering (AKS, 2021).

Soils

The Web Soil Survey published by the United States Department of Agriculture (USDA) Natural Resources Conservation Service (NRCS) was referenced to determine the soil names, symbols, and hydrologic soil groups found on the project site. The soil type within the project area is identified as Aloha silt loam (1A). These soils are classified as hydrologic soil type C/D, which in an undrained condition generally exhibit very slow infiltration rates when thoroughly wet. The USDA soil survey map and the corresponding hydrologic soil group (HSG) for the area of interest are provided in Appendix A.

A geotechnical investigation was conducted to more accurately determine the site strata and infiltration rates. The field exploitation did not encounter the static groundwater table, but perched groundwater conditions may occur during the wet season. The onsite Geotechnical Memorandum by Hardman Geotechnical Services is included in Appendix B.

Flood Hazard

The proposed development for this site is located outside the 100-year floodplain boundary designated by the Federal Emergency Management Agency (FEMA) Flood Insurance Rate Map (FIRM) for Clackamas County, Oregon and Incorporated Areas, Panel 234, June 17, 2008, and in non-printed Flood Map Boundary Area. See Appendix A for the FIRMette of the proposed site.

Section 4. Methodology

The stormwater system for the proposed Frog Pond Oaks development was modeled using the following methods and design standards:

- **Water Quality:** The City of Wilsonville requires capture and treatment of 80% of the average annual runoff (approximately 1-inch in 24 hours). The City of Wilsonville has adopted a BMP Sizing Tool that was developed to aid in the design of detention and water quality low impact development facilities. The City of Wilsonville BMP Sizing Tool was used to size the minimum facility footprint areas to meet the water quality treatment standard.
- **Flow Control:** The BMP sizing tool was also simultaneously used to calculate facility sizes to include flow control. This tool provides the necessary calculations to design a facility to meet the City's flow

duration matching standards whereby the “duration of peak flow rates from post development conditions shall be less than or equal to the duration of peak flow rates from pre-development conditions for all peak flows between 42% of the 2-year storm peak flow rate up to the 10-year peak flow rate.” It is assumed that a facility designed using the City’s corresponding details with the calculated footprint area, orifice sizing and elevations will meet the City’s standards.

- Conveyance: The Santa Barbara Urban Hydrograph (SBUH) method was used to calculate design conveyance flow rates and XP-SWMM software was used to design the project conveyance system. The City’s design event for pipe conveyance is the 25-year, 24-hour storm, requiring 1-foot of freeboard between the hydraulic grade line and finished grade at structure rims.

BMP Sizing Tool Hydrology

The BMP Sizing Tool was created to aid in designing low impact development facilities for both treating stormwater runoff and matching flow durations between target conditions and developed conditions. City standards consider target conditions to be pre-development, prior to any human settlement. City of Wilsonville standards stipulate that the pre-developed vegetation of Oak Savannah, which applies to the project site, should be modeled in the sizing tool as grass. Proposed conditions were set to paved conditions for roof, roadway, and sidewalk, and set to landscaped conditions for landscaped and other disturbed pervious areas within the project boundary.

Vegetated filtration swales and rain gardens will function to provide both water quality and flow control mitigation. The BMP Sizing Tool provides minimum facility footprint areas for treatment and flow control. The BMP Sizing Tool also provides the required orifice sizes for incorporating the flow control component into these facilities.

Drainage

The developed portion of the site ultimately drains to Willow Creek over a mile north of the creek’s confluence with the Willamette River. Only a portion of undeveloped area will continue to shed toward Boeckman Creek. The site connects to the conveyance pipes in Frog Pond Lane that were constructed with the Frog Pond Ridge development. The Frog Pond Ridge pipe network analysis is included in Appendix C and shows that the pipes in Frog Pond Lane and Willow Creek Drive have capacity for the runoff generated by the Frog Pond Oaks site. Otak conducted a downstream impact analysis on the downstream section of Willow Creek per City of Wilsonville standards and the downstream impact analysis is included in Appendix C.

Conveyance

The proposed development will include a piped conveyance network that will convey flows to Willow Creek. Pipes draining the project site will be designed to meet City of Wilsonville conveyance standards.

The Santa Barbara Urban Hydrograph (SBUH) method will be used to calculate runoff rates generated under proposed conditions for contributing areas. The City of Wilsonville Public Works Standards (2015) identifies the 25-year, 24-hour storm to be used for conveyance design, maintaining 1-foot of clearance between the hydraulic grade line and conveyance structure rim elevations. The City also requires an assessment of the 100-year storm event impacts to the proposed system. Flow rates during the 100-year may be conveyed overland but are not expected to inundate existing structures. The stormwater conveyance network will be sized during final design.

Section 5. Water Quality Treatment

Low Impact Development

The City of Wilsonville promotes the use of Low Impact Development (LID) approaches to meet water quality treatment standards. Locations of LID facilities for water quality treatment for the Frog Pond Oaks project site are shown on Figure 2.

Water Quality Facilities

Water quality treatment will be provided through vegetated filtration swales and rain gardens. The BMP Sizing Tool was used to calculate minimum facility sizes to satisfy water quality requirements. Facility sizing calculation reports from the BMP Sizing Tool are provided in Appendix D.

Section 6. Flow Control

City of Wilsonville Public Works Standards (2015) requires the use of flow attenuation when a proposed development increases impervious surface area by more than 5,000 square feet. Therefore, this project site will require flow control mitigation prior to discharging site runoff to downstream conveyance systems (open or closed channels or conduits). Per City requirements, the “post-development conditions shall be less than or equal to the duration of peak flow rates from pre-development conditions for all peak flows between 42% of the 2-year storm peak flow rate up to the 10-year peak flow rate.”

Flow control structures will be located immediately downstream of vegetated filtration swales and rain gardens, per the City’s standard detail. These facilities provide flow control by installing orifices at the end of their corresponding underdrain pipes to backwater flows into the available storage and voids present in facility soil and rock layers. Water is released from the facility through the orifice, which is sized to meter flows at a rate that meets flow control standards.

Orifices are provided for flow control purposes only; construction details of the flow control structures are provided on the plan sheets. Construction details of the flow control structures are provided on the plan sheets. A summary of facilities to serve this project is presented in Table 3.

Table 3 Facility Summary Table

Basin ID	Facility ID	Function	LID Min. Size, BMP Output (sf)	LID Treatment Size, Site Plan (sf)	Orifice Diameter (in)
O-M1	Rain garden SW	WQ, FC	7,243	7,265	4.2
O-M2	Rain garden SE	WQ, FC	5,398	5,400	4.0
O-W1	Swale	WQ, FC	253	352	0.9
O-W2	Swale	WQ, FC	360	360	1.1
O-F1	Swale	WQ, FC	307	352	1.0
O-F2	Swale	WQ, FC	423	424	1.2
O-S1	Swale	WQ, FC	64	103	0.5
O-S2	Swale	WQ, FC	127	128	0.7
O-S3	Swale	WQ, FC	194	240	0.8

Section 7. Operations and Maintenance

Vegetated facilities will be maintained by the private development. Operations and Maintenance requirements are included in Appendix E in conjunction with corresponding standard details for each type of facility. The following representative will be responsible for ongoing maintenance of onsite facilities: Dan Grimberg, Director of Land Development at West Hills Development, 503-641-7342.

Section 8. Conclusion

The proposed Frog Pond Oaks development will include a stormwater management system designed to comply with standards set forth by the City of Wilsonville. The proposed development will create 5.31 acres of impervious area. Approximately 1.71 acres of the existing 2.54 acre Boekman Creek drainage basin will remain undeveloped and continue to drain offsite. Runoff from proposed impervious areas will be treated by LID facilities, including vegetated filtration swales and rain gardens. Flow control requirements will also be met by adding orifices at the downstream end of LID facility underdrains to regulate outflows from the vegetated swales and rain gardens. The BMP Sizing Tool was used to calculate minimum facility and orifice sizes to satisfy water quality and flow control requirements. In accordance with City of Wilsonville standards, the conveyance system will be sized to convey the 25-year, 24-hour storm event with a minimum of one foot of freeboard between the hydraulic grade line (HGL) and the finished grade elevation. Otak conducted a downstream impact analysis on the downstream section of Willow Creek per City of Wilsonville standards.

Section 9. References

AKS, 2021. *Frog Pond Oaks Significant Resource Overlay Zone (SROZ) Map Verification*, AKS Engineering & Forestry, October 2021.

City of Wilsonville, 2015. *City of Wilsonville Public Works Standards. Section 3, Stormwater & Surface Water Design and Construction Standards 2015*; Revised December 2015.

DEQ, 2016. *Section 401 Water Quality Certification*, State of Oregon Department of Environmental Quality, May 2016.

FEMA, 2017. *FEMA Map Service Center*. <<http://msc.fema.gov/>> Accessed: December 11, 2019.

Hardman, 2018. *Geotechnical Engineering Report Miller Property – 6725 SW Frog Pond Lane Wilsonville, Clackamas County, Oregon*, Hardman Geotechnical Services Inc., May 23, 2018.

National Resource Conservation Services, 2018. *United States Department of Agriculture. Web Soil Survey*. <<http://websoilsurvey.nrcs.usda.gov/>> Accessed: December 30, 2020.

SCS, 1986. *Technical Release 55: Urban Hydrology for Small Watersheds*, United States Department of Agriculture Soil Conservation Service, June 1986.

USACE, 2014. *Standard Local Operating Procedures for Endangered Species (SLOPES V) to Administer Maintenance or Improvement of Stormwater, Transportation or Utility Actions*, United States Army Corps of Engineers, March 14, 2014.

Figures

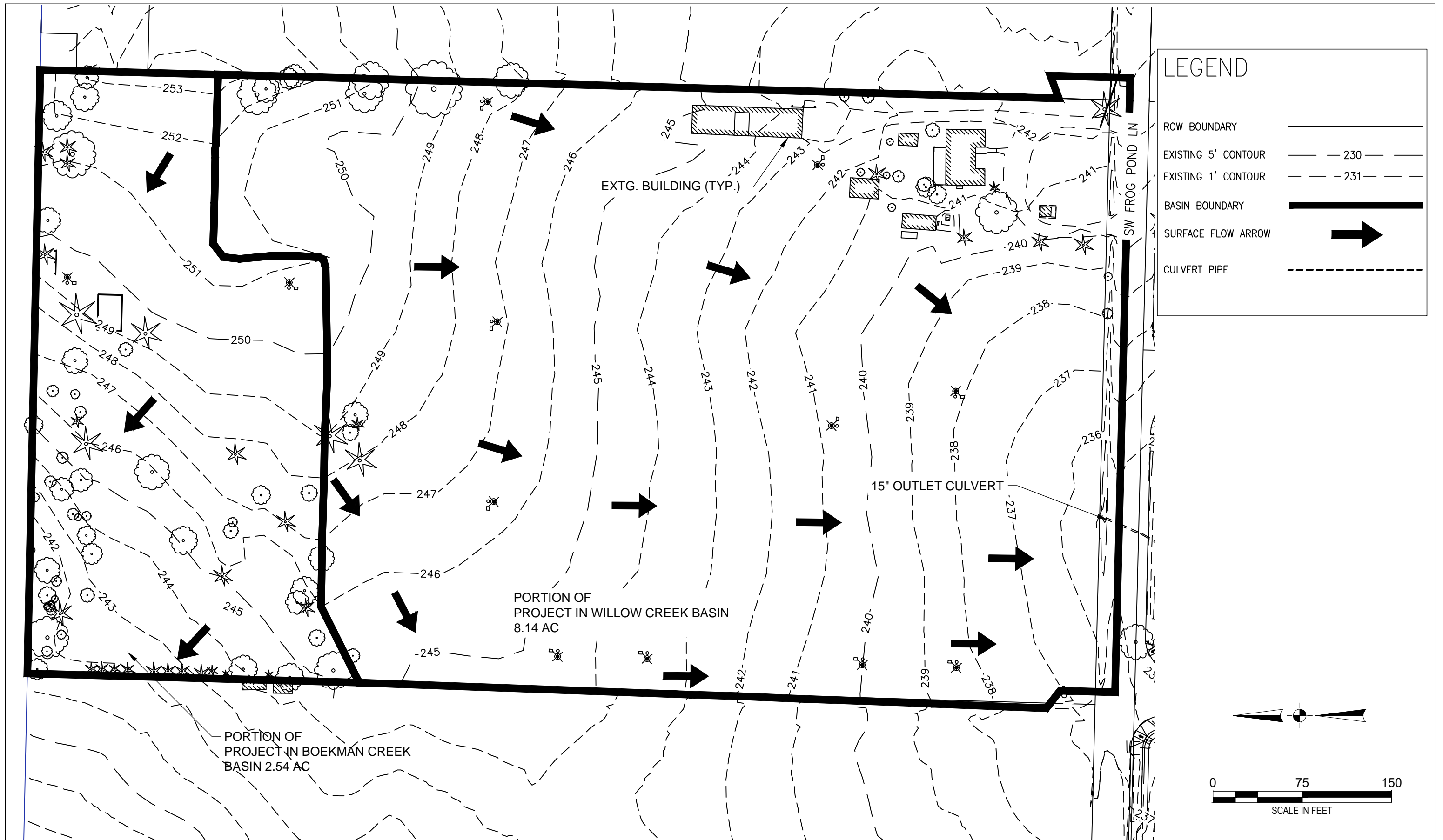

FROG POND OAKS | PRELIMINARY DESIGN | EXISTING CONDITIONS

FIG 1 | DATE: 10/07/2021 | PROJECT NUMBER: 20141



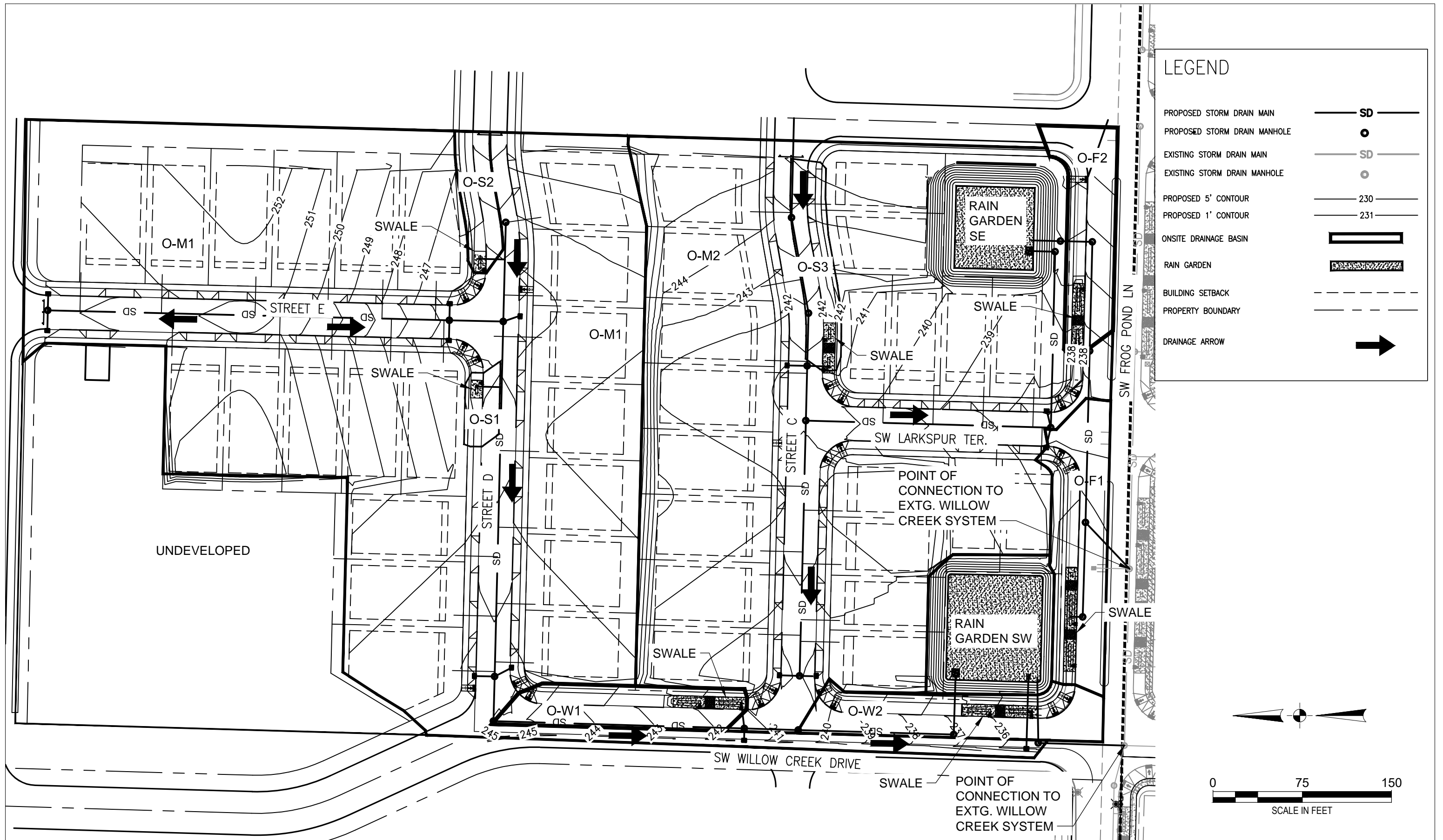

FROG POND OAKS | PRELIMINARY DESIGN | PROPOSED CONDITIONS

FIG 2 | DATE: 10/07/2021 | PROJECT NUMBER: 20141



Appendix A

Hydrology

Hydrologic Soil Group—Clackamas County Area, Oregon

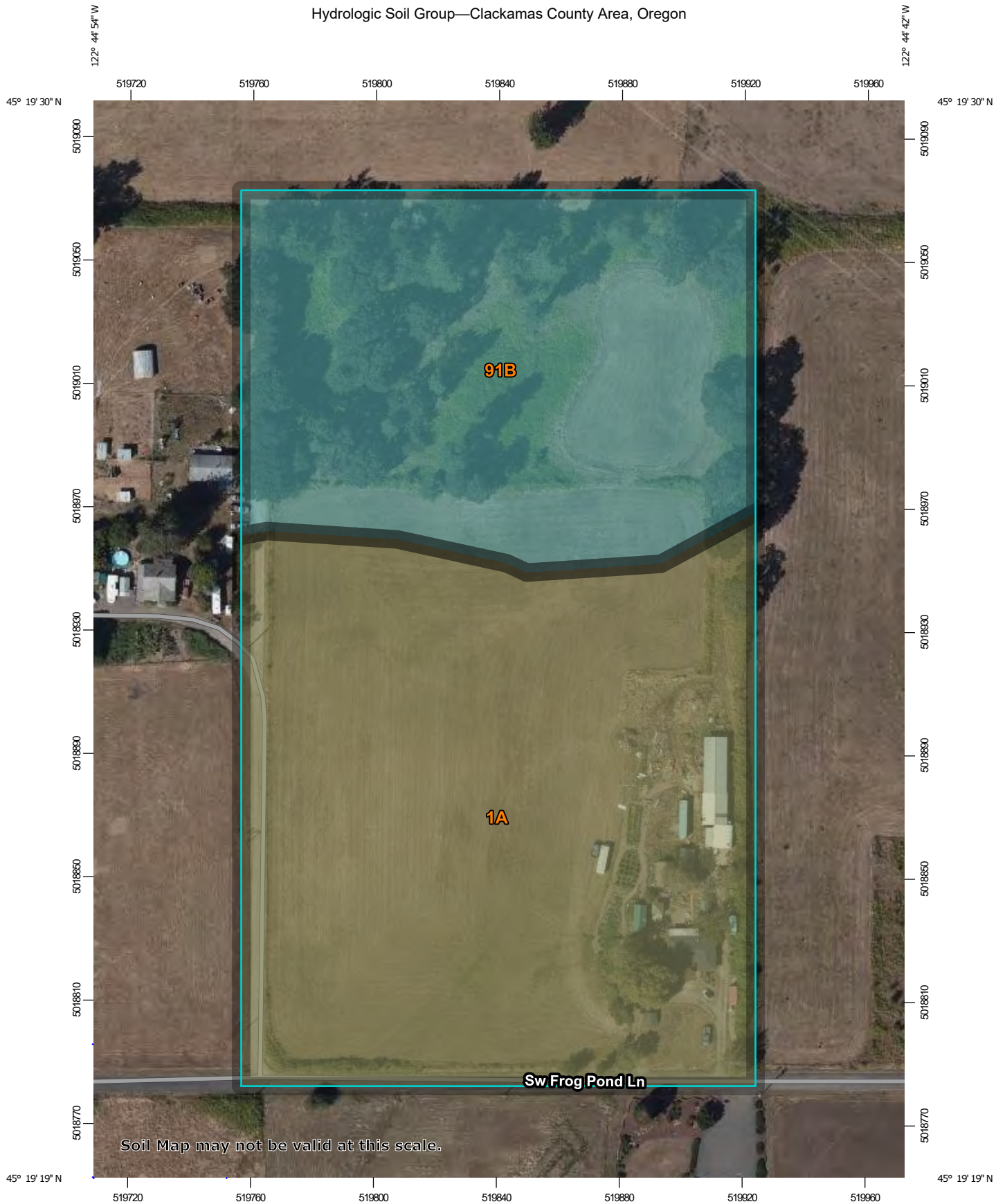

Map Scale: 1:1,700 if printed on A portrait (8.5" x 11") sheet.

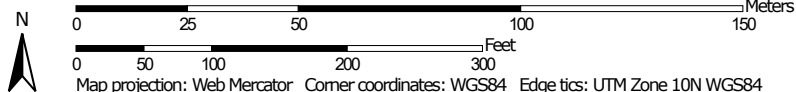

Map projection: Web Mercator Corner coordinates: WGS84 Edge tics: UTM Zone 10N WGS84



MAP LEGEND

Area of Interest (AOI)









 Area of Interest (AOI)

Soils

Soil Rating Polygons





 A
 A/D
 B
 B/D
 C
 C/D
 D
 Not rated or not available

Soil Rating Lines

 A
 A/D
 B
 B/D
 C
 C/D
 D
 Not rated or not available

Soil Rating Points





 A
 A/D
 B
 B/D

 C
 C/D
 D
 Not rated or not available

Water Features

 Streams and Canals

Transportation

 Rails
 Interstate Highways
 US Routes
 Major Roads
 Local Roads

Background

 Aerial Photography

MAP INFORMATION

The soil surveys that comprise your AOI were mapped at 1:20,000.

Warning: Soil Map may not be valid at this scale.

Enlargement of maps beyond the scale of mapping can cause misunderstanding of the detail of mapping and accuracy of soil line placement. The maps do not show the small areas of contrasting soils that could have been shown at a more detailed scale.

Please rely on the bar scale on each map sheet for map measurements.

Source of Map: Natural Resources Conservation Service
 Web Soil Survey URL:
 Coordinate System: Web Mercator (EPSG:3857)

Maps from the Web Soil Survey are based on the Web Mercator projection, which preserves direction and shape but distorts distance and area. A projection that preserves area, such as the Albers equal-area conic projection, should be used if more accurate calculations of distance or area are required.

This product is generated from the USDA-NRCS certified data as of the version date(s) listed below.

Soil Survey Area: Clackamas County Area, Oregon
 Survey Area Data: Version 16, Jun 11, 2020

Soil map units are labeled (as space allows) for map scales 1:50,000 or larger.

Date(s) aerial images were photographed: Aug 1, 2019—Sep 12, 2019

The orthophoto or other base map on which the soil lines were compiled and digitized probably differs from the background imagery displayed on these maps. As a result, some minor shifting of map unit boundaries may be evident.

Hydrologic Soil Group

Map unit symbol	Map unit name	Rating	Acres in AOI	Percent of AOI
1A	Aloha silt loam, 0 to 3 percent slopes	C/D	7.2	60.0%
91B	Woodburn silt loam, 3 to 8 percent slopes	C	4.8	40.0%
Totals for Area of Interest			12.1	100.0%

Description

Hydrologic soil groups are based on estimates of runoff potential. Soils are assigned to one of four groups according to the rate of water infiltration when the soils are not protected by vegetation, are thoroughly wet, and receive precipitation from long-duration storms.

The soils in the United States are assigned to four groups (A, B, C, and D) and three dual classes (A/D, B/D, and C/D). The groups are defined as follows:

Group A. Soils having a high infiltration rate (low runoff potential) when thoroughly wet. These consist mainly of deep, well drained to excessively drained sands or gravelly sands. These soils have a high rate of water transmission.

Group B. Soils having a moderate infiltration rate when thoroughly wet. These consist chiefly of moderately deep or deep, moderately well drained or well drained soils that have moderately fine texture to moderately coarse texture. These soils have a moderate rate of water transmission.

Group C. Soils having a slow infiltration rate when thoroughly wet. These consist chiefly of soils having a layer that impedes the downward movement of water or soils of moderately fine texture or fine texture. These soils have a slow rate of water transmission.

Group D. Soils having a very slow infiltration rate (high runoff potential) when thoroughly wet. These consist chiefly of clays that have a high shrink-swell potential, soils that have a high water table, soils that have a claypan or clay layer at or near the surface, and soils that are shallow over nearly impervious material. These soils have a very slow rate of water transmission.

If a soil is assigned to a dual hydrologic group (A/D, B/D, or C/D), the first letter is for drained areas and the second is for undrained areas. Only the soils that in their natural condition are in group D are assigned to dual classes.

Rating Options

Aggregation Method: Dominant Condition

Component Percent Cutoff: None Specified

Tie-break Rule: Higher



J

JOINS PANEL 0253

Site located in non-printed area



MAP SCALE 1" = 500'

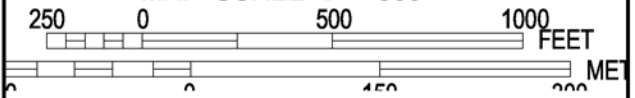

NFIP

PANEL 0234D

NATIONAL FLOOD INSURANCE PROGRAM

FIRM
FLOOD INSURANCE RATE MAP
CLACKAMAS COUNTY,
OREGON
AND INCORPORATED AREAS

PANEL 234 OF 1175
 (SEE MAP INDEX FOR FIRM PANEL LAYOUT)

CONTAINS:

<u>COMMUNITY</u>	<u>NUMBER</u>	<u>PANEL</u>	<u>SUFFIX</u>
CLACKAMAS COUNTY	415588	0234	D
WILSONVILLE, CITY OF	410025	0234	D

Notice to User: The **Map Number** shown below should be used when placing map orders; the **Community Number** shown above should be used on insurance applications for the subject community.



MAP NUMBER
41005C0234D
EFFECTIVE DATE
JUNE 17, 2008

Federal Emergency Management Agency

This is an official copy of a portion of the above referenced flood map. It was extracted using F-MIT On-Line. This map does not reflect changes or amendments which may have been made subsequent to the date on the title block. For the latest product information about National Flood Insurance Program flood maps check the FEMA Flood Map Store at www.msc.fema.gov

Drainage Basin Areas

20141 Frog Pond Oaks

Existing Conditions:

Basin Name	Impervious Area		Pervious Area		Total Area	
	Total (sf)	Total (ac)	Total (sf)	Total (ac)	(sf)	(ac)
Willow Creek	15,411	0.35	339,363	7.79	354,774	8.14
Boekman Creek	0	0.00	110,742	2.54	110,742	2.54
TOTAL	15,411	0.35	450,105	10.33	465,516	10.69

Large Impervious Area per Lot
Impervious Area per Lot

3,050 SF
2,750 SF (2015 Public Works Stds 301.4.01)

Proposed Conditions:

41.0 lots

Basin	Drains To	Treated By	Impervious Area				Pervious Area		Total Area	
			Roadway (sf)	Roof (sf)	Total (sf)	Total (ac)	(sf)	(ac)	(sf)	(ac)
Site Total			89,948	112,750	231,514	5.31	152,936	3.67	465,779	10.69
O-M1		raingarden SW	53,147	57,750	110,897	2.55	91,310	2.10	202,207	4.64
O-M2		raingarden SE	36,801	55,000	91,801	2.11	61,626	1.41	153,427	3.52
O-W1		swale	5,138	0.00	5,138	0.12	1,697	0.04	6,835	0.16
O-W2		swale	7,700	0.00	7,700	0.18	1,856	0.04	9,556	0.22
O-F1		swale	6,605	0.00	6,605	0.15	1,508	0.03	8,113	0.19
O-F2		swale	9,373	0.00	9,373	0.22	1,705	0.04	11,078	0.25
Undeveloped		NA	0	0.00	0	0.00	74,563	1.71	74,563	1.71

* 52% Type D soil/48% Type C soil

Appendix B

Geotech Report



July 17, 2018
HGSI Project No. 18-2338

Dan Grimberg / Miriam Wilson
West Hills Land Development
3330 NW Yeon Avenue, Suite 200
Portland, Oregon 97210

Via e-mail (pdf format); hard copies can be mailed on request

**Subject: GEOTECHNICAL ENGINEERING REPORT
MILLER PROPERTY
6725 SW FROG POND LANE
WILSONVILLE, CLACKAMAS COUNTY, OREGON**

This report presents the results of a geotechnical engineering study conducted by Hardman Geotechnical Services Inc. (HGSI) for the property at 6720 SW Frog Pond Lane in Wilsonville, Oregon (Figure 1). The purpose of this study was to evaluate subsurface conditions at the site and to provide geotechnical recommendations for site development. This geotechnical study was performed in accordance with HGSI Proposal No. 18-763, dated July 2, 2018, and your subsequent authorization of our proposal and *General Conditions for Geotechnical Services*.

SITE DESCRIPTION AND PROPOSED DEVELOPMENT

Our understanding of the site and project conditions is based on a review of information provided, and property data obtained online from Clackamas County. The project consists of two contiguous tax lots, totaling about 10.4 acres, as summarized below. Please note that the parcel addresses and acreages were taken from the Clackamas County GIS website and may not be completely accurate.

Tax Lot No.	Address	Acreage	House Constructed Date
31W12D 00401	Miller Property 6725 SW Frog Pond Lane	5.20	1960
31W12D 00402	No Address	5.22	N/A

The southeast corner of the property has an existing house, and several outbuildings ranging from a small shed to a large barn/shop structure north of the house. Site vegetation consists of lawn, landscaping shrubs and trees around the existing home. The majority of the property is grass field or pasture, with a treed area in the northwest corner. Site slopes are gentle, generally down toward the south. The site is within an area of rural residential properties.

The proposed development includes grading the site to support residential lots, with associated underground utilities, roadways and water quality facilities. Details of the planned lot and street layout, and proposed grading, have not yet been developed. HGSI should review the grading plan when available to verify

July 17, 2018

HGSI Project No. 18-2338

consistency with the geotechnical recommendations, and to provide any supplemental or revised input to the design needed based on geotechnical considerations.

REGIONAL GEOLOGY AND SEISMIC SETTING

The subject site lies within the Portland Basin, a broad structural depression situated between the Coast Range on the west and the Cascade Range on the east. The Portland Basin is a northwest-southwest trending structural basin produced by broad regional downwarping of the area. The Portland Basin is approximately 20 miles wide and 45 miles long and is filled with consolidated and unconsolidated sedimentary rocks of late Miocene, Pliocene and Pleistocene age.

The subject site is underlain by Quaternary age (last 1.6 million years) loess, a windblown silt deposit that mantles older deposits and basalt bedrock in the Portland Hills (Madin, 1990). The loess generally consists of massive silt deposited following repeated catastrophic flooding events in the Willamette Valley, the last of which occurred about 10,000 years ago. In localized areas, the loess includes buried paleosols that developed between depositional events. Regionally, the total thickness of loess ranges from 5 feet to greater than 100 feet.

The loess is underlain by residual soil formed by in place weathering of the underlying Columbia River Basalt Formation (Madin, 1990). The Miocene aged (about 14.5 to 16.5 million years ago) Columbia River Basalts are a thick sequence of lava flows which form the crystalline basement of the Tualatin Valley. The basalts are composed of dense, finely crystalline rock that is commonly fractured along blocky and columnar vertical joints. Individual basalt flow units typically range from 25 to 125 feet thick and interflow zones are typically vesicular, scoriaceous, brecciated, and sometimes include sedimentary rocks.

At least three major fault zones capable of generating damaging earthquakes are known to exist in the region. These include the Portland Hills Fault Zone, Gales Creek-Newberg-Mt. Angel Structural Zone, and the Cascadia Subduction Zone. These potential earthquake source zones are included in the determination of seismic design values for structures, as presented in the *Seismic Design* section. None of the known faults extend beneath the site.

FIELD EXPLORATION – HAND AUGER BORINGS

The site-specific exploration for this study was conducted on July 16, 2018 and consisted of six hand auger borings (designated HA-1 through HA-6) excavated to maximum depths of approximately 8 feet below ground surface (bgs) at the approximate locations shown on Figure 2. It should be noted that exploration locations were determined in the field by pacing or taping distances from apparent property corners and other site features shown on the plans provided. As such, the locations of the explorations should be considered approximate.

Explorations were conducted under the full-time observation of HGSI personnel. Soil samples obtained from the borings were classified in the field and representative portions were placed in relatively air-tight plastic bags. These soil samples were then returned to the laboratory for further examination. Pertinent information including soil sample depths, stratigraphy, soil engineering characteristics, and groundwater occurrence was recorded. Soils were classified in general accordance with the Unified Soil Classification System.

Summary exploration logs are attached to this report. The stratigraphic contacts shown on the individual borehole logs represent the approximate boundaries between soil types. The actual transitions may be more gradual. The soil and groundwater conditions depicted are only for the specific dates and locations reported, and therefore, are not necessarily representative of other locations and times.

July 17, 2018

HGSI Project No. 18-2338

SUBSURFACE CONDITIONS

The following discussion is a summary of subsurface conditions encountered in our explorations. For more detailed information regarding subsurface conditions at specific exploration locations, refer to the attached hand auger logs. Also, please note that subsurface conditions can vary between exploration locations, as discussed in the *Uncertainty and Limitations* section below.

Soil

On-site soils are anticipated to consist of topsoil, clayey silt, and clay, as described below.

Topsoil – From the ground surface, all explorations encountered 1.5 to 2 feet of topsoil, comprised of moist silt. The upper about 1 foot of the topsoil was highly organic.

Clayey Silt to Silty Clay – Beneath the topsoil in the hand augers, we encountered stiff to very stiff, moist to wet, brown clayey silt to silty clay. The upper several feet of this unit exhibited orange and gray mottling. All of the explorations terminated in the clayey silt to silty clay unit, at maximum depth of about 5 feet bgs.

Groundwater

During the field exploration, no static groundwater table was encountered to the maximum depth of exploration at 8 feet bgs. Slight seepage was encountered in borings HA-1 and HA-4 at about 8 feet bgs. Perched groundwater conditions often occur over fine-grained native deposits such as those beneath the site, particularly during the wet season. It is anticipated that groundwater conditions will vary depending on the season, local subsurface conditions, changes in site utilization, and other factors. The groundwater conditions reported above are for the specific date and locations indicated, and therefore may not necessarily be indicative of other times and/or locations.

CONCLUSIONS AND RECOMMENDATIONS

Results of this study indicate that the proposed development is geotechnically feasible, provided that the recommendations of this report are incorporated into the design and construction phases of the project. Recommendations are presented below regarding site preparation and undocumented fill removal, engineered fill, wet weather earthwork, spread footing foundations, below grade structural retaining walls, concrete slabs-on-grade, perimeter footing drains, seismic design, excavating conditions and utility trench backfill, and erosion control considerations.

Site Preparation and Undocumented Fill Removal

The areas of the site to be graded should first be cleared of vegetation, undocumented fill, and any loose debris; and debris from clearing should be removed from the site. Organic-rich topsoil should then be removed to competent native soils. We anticipate that the average depth of topsoil stripping will be about 12 inches over most of the site, however deeper stripping may be needed in localized areas. The final depth of stripping removal may vary depending on local subsurface conditions and the contractor's methods, and should be determined on the basis of site observations after the initial stripping has been performed. Stripped organic soil should be stockpiled only in designated areas or removed from the site and stripping operations should be observed and documented by HGSI. Existing subsurface structures (tile drains, old utility lines, septic leach fields, etc.) beneath areas of proposed structures and pavement should be removed and the excavations backfilled with engineered fill.

There is potential for old fills to be present on site in areas beyond our explorations. Where encountered beneath proposed structures, pavements, or other settlement-sensitive improvements, undocumented fill

July 17, 2018

HGSI Project No. 18-2338

should be removed down to firm inorganic native soils and the removal area backfilled with engineered fill (see below). HGSI should observe removal excavations (if any) prior to fill placement to verify that overexcavations are adequate and an appropriate bearing stratum is exposed.

In construction areas, once stripping has been verified, the area should be ripped or tilled to a depth of 12 inches, moisture conditioned, and compacted in-place prior to the placement of engineered fill. Exposed subgrade soils should be evaluated by HGSI. For large areas, this evaluation is normally performed by proof-rolling the exposed subgrade with a fully loaded scraper or dump truck. For smaller areas where access is restricted, the subgrade should be evaluated by probing the soil with a steel probe. Soft/loose soils identified during subgrade preparation should be compacted to a firm and unyielding condition or over-excavated and replaced with engineered fill, as described below. The depth of overexcavation, if required, should be evaluated by HGSI at the time of construction.

Engineered Fill

In general, we anticipate that on-site soils will be suitable for use as engineered fill in dry weather conditions, provided they are relatively free of organics and are properly moisture conditioned for compaction. Imported fill material must be approved by the geotechnical engineer prior to being imported to the site. Oversize material greater than 6 inches in size should not be used within 3 feet of foundation footings, and material greater than 12 inches in diameter should not be used in engineered fill.

Engineered fill should be compacted in horizontal lifts not exceeding 8 inches using standard compaction equipment. We recommend that engineered fill be compacted to at least 90 percent of the maximum dry density determined by ASTM D1557 (Modified Proctor) or equivalent. On-site soils may be wet or dry of optimum; therefore, we anticipate that moisture conditioning of native soil will be necessary for compaction operations.

Proper test frequency and earthwork documentation usually requires daily observation and testing during stripping, rough grading, and placement of engineered fill. Field density testing should conform to ASTM D2922 and D3017, or D1556. Engineered fill should be periodically observed and tested by the project geotechnical engineer or his representative. Typically, one density test is performed for at least every 2 vertical feet of fill placed or every 500 yd³, whichever requires more testing.

Wet Weather Earthwork

The on-site soils are moisture sensitive and may be difficult to handle or traverse with construction equipment during periods of wet weather. Earthwork is typically most economical when performed under dry weather conditions. Earthwork performed during the wet-weather season will probably require expensive measures such as cement treatment or imported granular material to compact fill to the recommended engineering specifications. If earthwork is to be performed or fill is to be placed in wet weather or under wet conditions when soil moisture content is difficult to control, the following recommendations should be incorporated into the contract specifications.

- Earthwork should be performed in small areas to minimize exposure to wet weather. Excavation or the removal of unsuitable soils should be followed promptly by the placement and compaction of clean engineered fill. The size and type of construction equipment used may have to be limited to prevent soil disturbance. Under some circumstances, it may be necessary to excavate soils with a backhoe to minimize subgrade disturbance caused by equipment traffic;
- The ground surface within the construction area should be graded to promote run-off of surface water and to prevent the ponding of water;

July 17, 2018

HGSI Project No. 18-2338

- Material used as engineered fill should consist of clean, granular soil containing less than about 7 percent fines. The fines should be non-plastic. Alternatively, cement treatment of on-site soils may be performed to facilitate wet weather placement;
- The ground surface within the construction area should be sealed by a smooth drum vibratory roller, or equivalent, and under no circumstances should be left uncompacted and exposed to moisture. Soils which become too wet for compaction should be removed and replaced with clean granular materials;
- Excavation and placement of fill should be observed by the geotechnical engineer to verify that all unsuitable materials are removed and suitable compaction and site drainage is achieved; and
- Bales of straw and/or geotextile silt fences should be strategically located to control erosion.

If cement or lime treatment is used to facilitate wet weather construction, HGSI should be contacted to provide additional recommendations and field monitoring.

Spread Footing Foundations

Shallow, conventional isolated or continuous spread footings may be used to support the proposed structures, provided they are founded on competent native soils, or compacted engineered fill placed directly upon the competent native soils. We recommend a maximum allowable bearing pressure of 2,000 pounds per square foot (psf) for designing spread footings bearing on undisturbed native soils or engineered fill. The recommended maximum allowable bearing pressure may be increased by a factor of 1.33 for short term transient conditions such as wind and seismic loading. Exterior footings should be founded at least 18 inches below the lowest adjacent finished grade. Minimum footing widths should be determined by the project engineer/architect in accordance with applicable design codes.

Assuming construction is accomplished as recommended herein, and for the foundation loads anticipated, we estimate total settlement of spread foundations of less than about 1 inch and differential settlement between two adjacent load-bearing components supported on competent soil of less than about ½ inch. We anticipate that the majority of the estimated settlement will occur during construction, as loads are applied.

Wind, earthquakes, and unbalanced earth loads will subject the proposed structure to lateral forces. Lateral forces on a structure will be resisted by a combination of sliding resistance of its base or footing on the underlying soil and passive earth pressure against the buried portions of the structure. For use in design, a coefficient of friction of 0.5 may be assumed along the interface between the base of the footing and subgrade soils. Passive earth pressure for buried portions of structures may be calculated using an equivalent fluid weight of 390 pounds per cubic foot (pcf), assuming footings are cast against dense, natural soils or engineered fill. The recommended coefficient of friction and passive earth pressure values do not include a safety factor. The upper 12 inches of soil should be neglected in passive pressure computations unless it is protected by pavement or slabs on grade.

Footing excavations should be trimmed neat and the bottom of the excavation should be carefully prepared. Loose, wet or otherwise softened soil should be removed from the footing excavation prior to placing reinforcing steel bars. HGSI should observe foundation excavations prior to placing crushed rock, to verify that adequate bearing soils have been reached. Due to the high moisture sensitivity of on-site soils, construction during wet weather may require overexcavation of footings and backfill with compacted, crushed aggregate.

Below-Grade Structural Retaining Walls

Lateral earth pressures against below-grade retaining walls will depend upon the inclination of any adjacent slopes, type of backfill, degree of wall restraint, method of backfill placement, degree of backfill compaction, drainage provisions, and magnitude and location of any adjacent surcharge loads. At-rest soil pressure is

July 17, 2018

HGSI Project No. 18-2338

exerted on a retaining wall when it is restrained against rotation. In contrast, active soil pressure will be exerted on a wall if its top is allowed to rotate or yield a distance of roughly 0.001 times its height or greater. If the subject retaining walls will be free to rotate at the top, they should be designed for an active earth pressure equivalent to that generated by a fluid weighing 35 pcf for level backfill against the wall. For restrained walls, an at-reset equivalent fluid pressure of 54 pcf should be used in design, again assuming level backfill against the wall. These values assume that the recommended drainage provisions are incorporated, and hydrostatic pressures are not allowed to develop against the wall.

During a seismic event, lateral earth pressures acting on below-grade structural walls will increase by an incremental amount that corresponds to the earthquake loading. Based on the Mononobe-Okabe equation and peak horizontal accelerations appropriate for the site location, seismic loading should be modeled using the active or at-rest earth pressures recommended above, plus an incremental rectangular-shaped seismic load of magnitude $5H$, where H is the total height of the wall.

We assume relatively level ground surface below the base of the walls. As such, we recommend passive earth pressure of 390 pcf for use in design, assuming wall footings are cast against competent native soils or engineered fill. If the ground surface slopes down and away from the base of any of the walls, a lower passive earth pressure should be used and HGSI should be contacted for additional recommendations.

A coefficient of friction of 0.5 may be assumed along the interface between the base of the wall footing and subgrade soils. The recommended coefficient of friction and passive earth pressure values do not include a safety factor, and an appropriate safety factor should be included in design. The upper 12 inches of soil should be neglected in passive pressure computations unless it is protected by pavement or slabs on grade.

The above recommendations for lateral earth pressures assume that the backfill behind the subsurface walls will consist of properly compacted structural fill, and no adjacent surcharge loading. If the walls will be subjected to the influence of surcharge loading within a horizontal distance equal to or less than the height of the wall, the walls should be designed for the additional horizontal pressure. For uniform surcharge pressures, a uniformly distributed lateral pressure of 0.3 times the surcharge pressure should be added.

The recommended equivalent fluid densities assume a free-draining condition behind the walls so that hydrostatic pressures do not build up. This can be accomplished by placing a 12-inch wide zone of crushed drain rock containing less than 5 percent fines against the walls. A 3-inch minimum diameter perforated, plastic drain pipe should be installed at the base of the walls and connected to a sump to remove water from the crushed drain rock zone. The drain pipe should be wrapped in filter fabric (Mirafi 140N or other as approved by the geotechnical engineer) to minimize clogging. The above drainage measures are intended to remove water from behind the wall to prevent hydrostatic pressures from building up. Additional drainage measures may be specified by the project architect or structural engineer, for damp-proofing or other reasons.

HGSI should be contacted during construction to verify subgrade strength in wall keyway excavations, to verify that backslope soils are in accordance with our assumptions, and to take density tests on the wall backfill materials.

Concrete Slabs-on-Grade

Preparation of areas beneath concrete slab-on-grade floors should be performed as recommended in the *Site Preparation* section. Care should be taken during excavation for foundations and floor slabs, to avoid disturbing subgrade soils. If subgrade soils have been adversely impacted by wet weather or otherwise disturbed, the surficial soils should be scarified to a minimum depth of 8 inches, moisture conditioned to within about 3 percent of optimum moisture content, and compacted to engineered fill specifications. Alternatively, disturbed soils may be removed and the removal zone backfilled with additional crushed rock.

July 17, 2018

HGSI Project No. 18-2338

For evaluation of the concrete slab-on-grade floors using the beam on elastic foundation method, a modulus of subgrade reaction of 200 kcf (115 pci) should be assumed for the soils anticipated at subgrade depth. This value assumes the concrete slab system is designed and constructed as recommended herein, with a minimum thickness of crushed rock of 8 inches beneath the slab.

Interior slab-on-grade floors should be provided with an adequate moisture break. The capillary break material should consist of ODOT open graded aggregate per ODOT Standard Specifications 02630-2. The minimum recommended thickness of capillary break materials on re-compacted soil subgrade is 8 inches. The total thickness of crushed aggregate will be dependent on the subgrade conditions at the time of construction, and should be verified visually by proof-rolling. Under-slab aggregate should be compacted to at least 90% of its maximum dry density as determined by ASTM D1557 or equivalent.

In areas where moisture will be detrimental to floor coverings or equipment inside the proposed structure, appropriate vapor barrier and damp-proofing measures should be implemented. A commonly applied vapor barrier system consists of a 10-mil polyethylene vapor barrier placed directly over the capillary break material. With this type of system, an approximately 2-inch thick layer of sand is often placed over the vapor barrier to protect it from damage, to aid in curing of the concrete, and also to help prevent cement from bleeding down into the underlying capillary break materials. Other damp/vapor barrier systems may also be feasible. Appropriate design professionals should be consulted regarding vapor barrier and damp proofing systems, ventilation, building material selection and mold prevention issues, which are outside HGSI's area of expertise.

Perimeter Footing Drains

Due to the potential for perched surface water above fine grained deposits such as those encountered at the site, we recommend the outside edge of perimeter footings be provided with a drainage system consisting of 3-inch minimum diameter perforated PVC pipe embedded in a minimum of 1 ft³ per lineal foot of clean, free-draining sand and gravel or 1"- ¼" drain rock. The drain pipe and surrounding drain rock should be wrapped in non-woven geotextile (Mirafi 140N, or approved equivalent) to minimize the potential for clogging and/or ground loss due to piping. Water collected from the footing drains should be directed into the local storm drain system or other suitable outlet. A minimum 0.5 percent fall should be maintained throughout the drain and non-perforated pipe outlet. The footing drains should include clean-outs to allow periodic maintenance and inspection.

Down spouts and roof drains should collect roof water in a system separate from the footing drains in order to reduce the potential for clogging. Roof drain water should be directed to an appropriate discharge point well away from structural foundations. Grades should be sloped downward and away from buildings to reduce the potential for ponded water near structures.

Seismic Design

Structures should be designed to resist earthquake loading in accordance with the methodology described in the 2012 International Building Code (IBC) with applicable 2014 Oregon Structural Specialty Code (OSSC) revisions. We recommend Site Class C be used for design per the OSSC, which references ASCE 7-10, Chapter 20, Table 20.3-1. Design values determined for the site using the USGS (United States Geological Survey) *Earthquake Ground Motion Parameters* utility are summarized on Table 1.

Table 1. Recommended Earthquake Ground Motion Parameters (2012 IBC / 2014 OSSC)

Parameter	Value
Location (Lat, Long), degrees	45.3234, -122.7469
Mapped Spectral Acceleration Values (MCE, Site Class B):	
Short Period, S_s	0.930 g
1.0 Sec Period, S_1	0.409 g
Soil Factors for Site Class D:	
F_a	1.128
F_v	1.591
$SD_s = 2/3 \times F_a \times S_s$	0.700 g
$SD_1 = 2/3 \times F_v \times S_1$	0.434 g

Potential seismic impacts also include secondary effects such as soil liquefaction, fault rupture potential, and other hazards as discussed below:

- **Soil Liquefaction Potential** – Soil liquefaction is a phenomenon wherein saturated soil deposits temporarily lose strength and behave as a liquid in response to earthquake shaking. Soil liquefaction is generally limited to loose, granular soils located below the water table. Following development, on-site soils will consist predominantly of engineered fill or stiff clayey native soils above the water table, which are not considered susceptible to liquefaction. Therefore, it is our opinion that special design or construction measures are not required to mitigate the effects of liquefaction.
- **Fault Rupture Potential** – Based on our review of available geologic literature, we are not aware of any mapped active (demonstrating movement in the last 10,000 years) faults on the site. During our field investigation, we did not observe any evidence of surface rupture or recent faulting. Therefore, we conclude that the potential for fault rupture on site is low.
- **Seismic Induced Landslide** – Topography in the vicinity of the subject site is generally flat to gently sloping. The potential for slope instability and seismic induced landslide on site is considered very low.
- **Effects of Local Geology and Topography** – In our opinion, no additional seismic hazard will occur due to local geology or topography. The site is expected to have no greater seismic hazard than surrounding properties and the Wilsonville area in general.

Excavating Conditions and Utility Trench Backfill

We anticipate that on-site soils can be excavated using conventional heavy equipment such as scrapers and trackhoes to a depth of 8 feet and likely greater. Maintenance of safe working conditions, including temporary excavation stability, is the responsibility of the contractor. Actual slope inclinations at the time of construction should be determined based on safety requirements and actual soil and groundwater conditions. All temporary cuts in excess of 4 feet in height should be sloped in accordance with U.S. Occupational Safety and Health Administration (OSHA) regulations (29 CFR Part 1926), or be shored. The existing native soils classify as Type B Soil and temporary excavation side slope inclinations as steep as 1H:1V may be assumed for planning purposes. This cut slope inclination is applicable to excavations above the water table only.

Perched groundwater conditions often occur over fine-grained native deposits such as those beneath the site, particularly during the wet season. If encountered, the contractor should be prepared to implement an

July 17, 2018

HGSI Project No. 18-2338

appropriate dewatering system for installation of the utilities. At this time, we anticipate that dewatering systems consisting of ditches, sumps and pumps would be adequate for control of groundwater where encountered during construction conducted during the dry season. Regardless of the dewatering system used, it should be installed and operated such that in-place soils are prevented from being removed along with the groundwater.

Vibrations created by traffic and construction equipment may cause some caving and raveling of excavation walls. In such an event, lateral support for the excavation walls should be provided by the contractor to prevent loss of ground support and possible distress to existing or previously constructed structural improvements.

Utility trench backfill should consist of ¾"-0 crushed rock, compacted to at least 90% of the maximum dry density obtained by Modified Proctor (ASTM D1557) or equivalent. Initial backfill lift thicknesses for a ¾"-0 crushed aggregate base may need to be as great as 4 feet to reduce the risk of flattening underlying flexible pipe. Subsequent lift thickness should not exceed 1 foot. If imported granular fill material is used, then the lifts for large vibrating plate-compaction equipment (e.g. hoe compactor attachments) may be up to 2 feet, provided that proper compaction is being achieved and each lift is tested. Use of large vibrating compaction equipment should be carefully monitored near existing structures and improvements due to the potential for vibration-induced damage.

Adequate density testing should be performed during construction to verify that the recommended relative compaction is achieved. Typically, one density test is taken for every 4 vertical feet of backfill on each 200-lineal-foot section of trench.

Erosion Control Considerations

During our field exploration program, we did not observe soil types that would be considered highly susceptible to erosion. Erosion at the site during construction can be minimized by implementing the project erosion control plan, which should include judicious use of straw, bio-bags, silt fences, or other appropriate technology. Where used, erosion control devices should be in place and remain in place throughout site preparation and construction. Areas of exposed soil requiring immediate and/or temporary protection against exposure should be covered with either mulch or erosion control netting/blankets.

UNCERTAINTIES AND LIMITATIONS

We have prepared this report for the owner and his/her consultants for use in design of this project only. This report should be provided in its entirety to prospective contractors for bidding and estimating purposes; however, the conclusions and interpretations presented in this report should not be construed as a warranty of the subsurface conditions. Experience has shown that soil and groundwater conditions can vary significantly over small distances. Inconsistent conditions can occur between explorations that may not be detected by a geotechnical study. If, during future site operations, subsurface conditions are encountered which vary appreciably from those described herein, HGSI should be notified for review of the recommendations of this report, and revision of such if necessary.

Sufficient geotechnical monitoring, testing and consultation should be provided during construction to confirm that the conditions encountered are consistent with those indicated by explorations. Recommendations for design changes will be provided should conditions revealed during construction differ from those anticipated, and to verify that the geotechnical aspects of construction comply with the contract plans and specifications.

Within the limitations of scope, schedule and budget, HGSI executed these services in accordance with generally accepted professional principles and practices in the field of geotechnical engineering at the time the report was prepared. No warranty, expressed or implied, is made. The scope of our work did not include environmental assessments or evaluations regarding the presence or absence of wetlands or hazardous or toxic substances in the soil, surface water, or groundwater at this site.



We appreciate this opportunity to be of service.

Sincerely,

HARDMAN GEOTECHNICAL SERVICES INC.



Scott L. Hardman, P.E., G.E.
Geotechnical Engineer

- Attachments:
- References
 - Figure 1 – Vicinity Map
 - Figure 2 – Site Plan
 - Logs of Hand Auger Borings HA-1 through HA-6



REFERENCES

Beeson, M.H., Tolan, T.L., and Madin, I.P., 1991, Geologic map of the Portland Quadrangle, Multnomah, and Washington Counties, Oregon: Oregon Department of Geology and Mineral Industries Geological Map Series GMS-75, scale 1:24,000.

Madin, I.P., 1990, Earthquake hazard geology maps of the Portland metropolitan area, Oregon: Oregon Department of Geology and Mineral Industries Open-File Report 0-90-2, scale 1:24,000, 22 p.

Snyder, D.T., 2008, Estimated Depth to Ground Water and Configuration of the Water Table in the Portland, Oregon Area: U.S. Geological Survey Scientific Investigations Report 2008–5059, 41 p., 3 plates.

Yeats, R.S., Graven, E.P., Werner, K.S., Goldfinger, C., and Popowski, T., 1996, Tectonics of the Willamette Valley, Oregon: in Assessing earthquake hazards and reducing risk in the Pacific Northwest, Vol. 1: U.S. Geological Survey Professional Paper 1560, P. 183-222, 5 plates, scale 1:100,000.

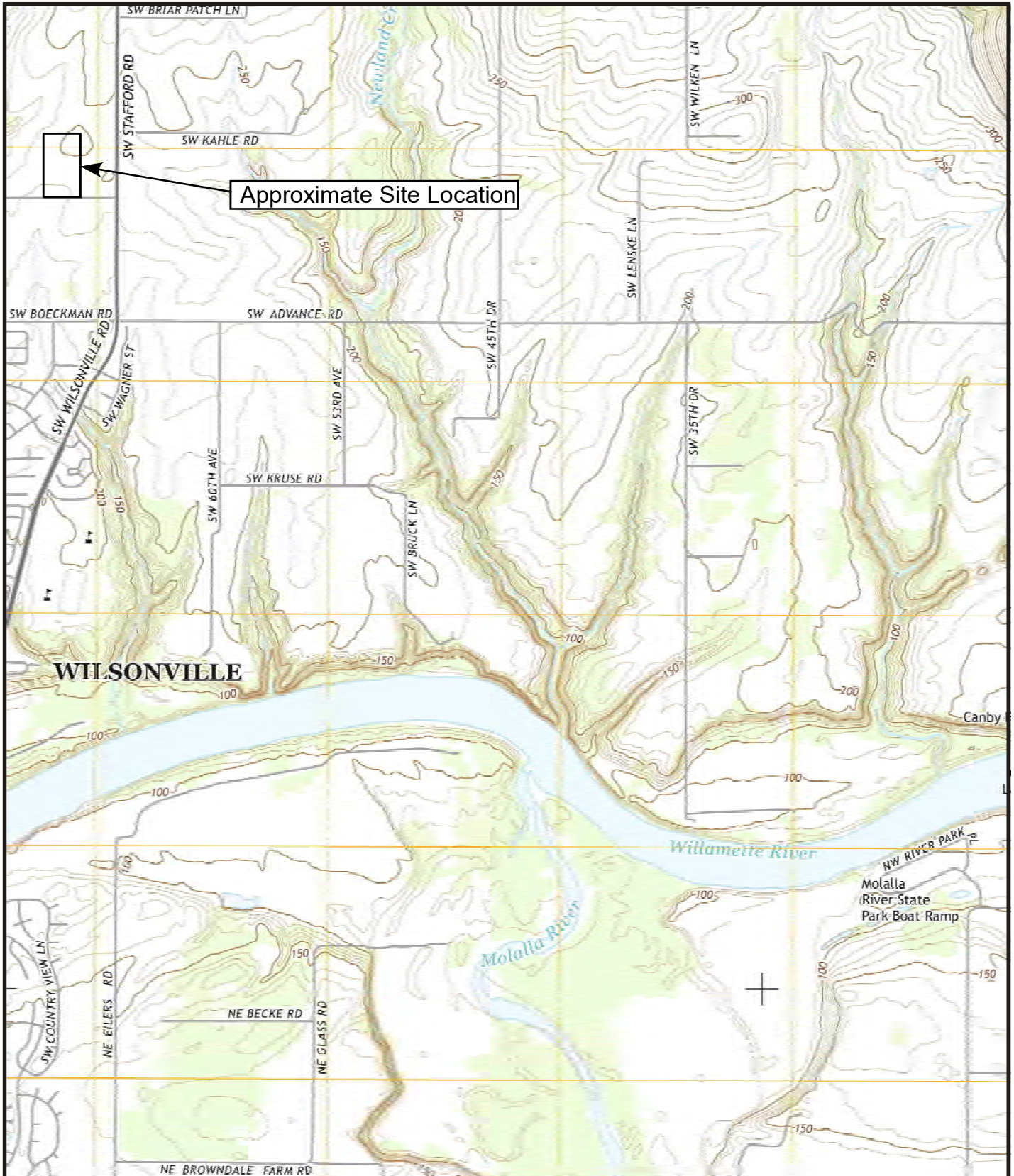

Project: Miller Property
Wilsonville, Oregon

Project No. 18-2338

FIGURE 1

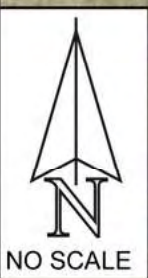

Legend



Approximate Site Location



Approximate Location of Hand Auger Boring

Base map provided by Google Earth

HAND AUGER BORING LOG

Project: Frog Pond - Miller Properties
Wilsonville, Oregon

Project No. 18-2338

Boring No. HA- 1

Depth (ft)	Sample Interval	Sample Designation	Pocket Penetrometer (tons/ft ²)	Moisture Content (%)	Groundwater	Material Description
1						Soft, highly organic SILT (OH), dark brown, moist (Topsoil)
2						Medium stiff, silty CLAY (CL), greyish brown with orange and gray mottling, moist (Willamette Formation)
3						
4						
5	☒					Very stiff, clayey SILT (MH), light brown with orange and gray mottling, slightly moist (Willamette Formation)
6						
7						
8					▽	Slight seepage at about 8 feet
9						Boring terminated at 8 feet
10						
11						
12						
13						
14						
15						

HGSI HARDMAN
GEO TECHNICAL
SERVICES INC.
Practical Cost-Effective Geotechnical Solutions
10110 SW Nimbus Avenue, Suite B-5
Portland, Oregon 97223
(503) 530-8076

LEGEND

▽
Observed seepage
at time of excavation

☒
Sample Depth

Date Excavated: 7/16/18
Logged By: CSH

HAND AUGER BORING LOG

Project: Frog Pond - Miller Properties
Wilsonville, Oregon

Project No. 18-2338

Boring No. HA- 2

Depth (ft)	Sample Interval	Sample Designation	Pocket Penetrometer (tons/ft ²)	Moisture Content (%)	Groundwater	Material Description
1						Soft, highly organic (grass roots) SILT (OH), dark brown, moist (Topsoil)
2						Soft, clayey SILT (MH), light brown with orange and gray mottling, slightly moist (Till zone / disturbed native soil)
3						
4						
5						Very stiff, clayey SILT (MH), light brown with orange and gray mottling, slightly moist (Willamette Formation)
6						Boring terminated at 6 feet No groundwater encountered
7						
8						
9						
10						
11						
12						
13						
14						
15						

HGSI HARDMAN
GEO TECHNICAL
SERVICES INC.
Practical Cost-Effective Geotechnical Solutions

10110 SW Nimbus Avenue, Suite B-5
Portland, Oregon 97223
(503) 530-8076

LEGEND

 Observed seepage at time of excavation

 Sample Depth

Date Excavated: 7/16/18
Logged By: CSH

HAND AUGER BORING LOG

Project: Frog Pond - Miller Properties
Wilsonville, Oregon

Project No. 18-2338

Boring No. HA- 3

Depth (ft)	Sample Interval	Sample Designation	Pocket Penetrometer (tons/ft ²)	Moisture Content (%)	Groundwater	Material Description
1						Soft, highly organic (grass roots) SILT(OL), light brown, dessicated
2						Very stiff, SILT (ML), light brown with orange and gray mottling, slightly moist (Willamette Formation)
3						Very stiff, clayey SILT (MH), light brown with orange and gray mottling, slightly moist (Willamette Formation)
4						
5						
6						
7						
8						Boring terminated at 8 feet No groundwater encountered
9						
10						
11						
12						
13						
14						
15						

HGSI HARDMAN
GEOTECHNICAL
SERVICES INC.
Practical Cost-Effective Geotechnical Solutions
10110 SW Nimbus Avenue, Suite B-5
Portland, Oregon 97223
(503) 530-8076

LEGEND

Observed seepage
at time of excavation

Sample Depth

Date Excavated: 7/16/18
Logged By: CSH

HAND AUGER BORING LOG

Project: Frog Pond - Miller Properties
Wilsonville, Oregon

Project No. 18-2338

Boring No. HA- 4

Depth (ft)	Sample Interval	Sample Designation	Pocket Penetrometer (tons/ft ²)	Moisture Content (%)	Groundwater	Material Description
1						Soft, highly organic (grass roots) SILT(OL), light brown, dessicated
2						Very stiff, SILT (ML), light brown with orange and gray mottling, slightly moist (Willamette Formation)
3						
4						Very stiff, clayey SILT (MH), light brown with orange and gray mottling, moist (Willamette Formation)
5						
6	☒					Material moistening with depth
7						
8					▽	Slight seepage at 8 feet
9						Boring terminated at 8 feet
10						
11						
12						
13						
14						
15						

HGSI HARDMAN
GEOTECHNICAL
SERVICES INC.
Practical Cost-Effective Geotechnical Solutions
10110 SW Nimbus Avenue, Suite B-5
Portland, Oregon 97223
(503) 530-8076

LEGEND

▽
Observed seepage
at time of excavation

☒
Sample Depth

Date Excavated: 7/16/18
Logged By: CSH

HAND AUGER BORING LOG

Project: Frog Pond - Miller Properties
Wilsonville, Oregon

Project No. 18-2338

Boring No. HA- 5

Depth (ft)	Sample Interval	Sample Designation	Pocket Penetrometer (tons/ft ²)	Moisture Content (%)	Groundwater	Material Description
1						Soft, highly organic (grass roots) SILT(OL), light brown, dessicated
2						Very stiff, SILT (ML), light brown with orange and gray mottling, slightly moist (Willamette Formation)
3						Very stiff, clayey SILT (MH), light brown with orange and gray mottling, slightly moist
4						(Willamette Formation)
5						
6						
7						
8						Boring terminated at 8 feet No groundwater encountered
9						
10						
11						
12						
13						
14						
15						

HGSI HARDMAN
GEOTECHNICAL
SERVICES INC.
Practical Cost-Effective Geotechnical Solutions
10110 SW Nimbus Avenue, Suite B-5
Portland, Oregon 97223
(503) 530-8076

LEGEND

 Observed seepage at time of excavation

 Sample Depth

Date Excavated: 7/16/18
Logged By: CSH

HAND AUGER BORING LOG

Project: Frog Pond - Miller Properties
Wilsonville, Oregon

Project No. 18-2338

Boring No. HA- 6

Depth (ft)	Sample Interval	Sample Designation	Pocket Penetrometer (tons/ft ²)	Moisture Content (%)	Groundwater	Material Description
1						Soft, highly organic (grass roots) SILT(OL), light brown, dessicated
2						Very stiff, SILT (ML), light brown with orange and gray mottling, slightly moist (Willamette Formation)
3						
4						Very stiff, clayey SILT (MH), light brown with orange and gray mottling, slightly moist (Willamette Formation)
5						
6						Boring terminated at 6 feet No groundwater encountered
7						
8						
9						
10						
11						
12						
13						
14						
15						

HGSI HARDMAN
GEOTECHNICAL
SERVICES INC.
Practical Cost-Effective Geotechnical Solutions
10110 SW Nimbus Avenue, Suite B-5
Portland, Oregon 97223
(503) 530-8076

LEGEND

 Observed seepage at time of excavation

 Sample Depth

Date Excavated: 7/16/18
Logged By: CSH

Appendix C

DownStream Analysis





Memorandum

To: Keith Buisman, PE
From: Rose Horton, PE
Copies: FILES
Date: October 8, 2021
Subject: Downstream Impact Analysis of Willow Creek Full Buildout
Project No.: 20141

Introduction

Otak has conducted a downstream impact analysis on the downstream storm conveyance system for the proposed Frog Pond Estates and Frog Pond Oaks developments, per City of Wilsonville standards. These proposed developments are located adjacent to SW Frog Pond Lane and west of SW Stafford Road, as shown on vicinity map.



Image 1- Vicinity Map

These developments will meet the City of Wilsonville Public Work Standards Section 301.4.04 which requires flow control from post-development conditions for peak flow rates generated by between 42% of the 2-year storm up to the 10-year storm.

To meet the requirements of City of Wilsonville Public Work Standards Section 301.5.01, a downstream analysis shall include:

- verifying that the downstream system has the capacity to convey the 25-year design storm
- extending the analysis downstream to a point in the drainage system where the proposed development site contributes 10% or less of the total tributary drainage flow or for one-quarter mile downstream of the approved point of discharge. The latter was applied in this case.

Existing Conditions

The extent of the analysis of the existing conveyance system and the contributing drainage basins is shown on Figure 1. Details of the downstream conveyance system used to create the hydraulic model were primarily obtained from City GIS as-built information, and field observation. The proposed Frog Pond Estates and Frog Pond Oaks development will discharge runoff into the existing Willow Creek channel running south of the site. The creek is conveyed south under SW Boeckman Road through a pair of 18" culverts and then runs in a grassed channel through a neighborhood. The channel is collected in a 36" diameter pipe that crosses under SW Willow Creek Drive where it is joined by runoff from the neighborhood. This point is the end of the analysis. The combined flows then drain to a deep channel which outfalls to the Willamette River over a mile downstream.

Hydrology

Peak runoff rates from the drainage basins delineated in Figure 1, during proposed conditions were calculated using XP-SWMM V19. The Santa Barbara Urban Hydrograph (SBUH) method was used to apply the conveyance design event (25-year recurrence interval, 24-hour duration, NRCS Type 1A rainfall distribution), per Section 301.5.01. Time of Concentration values were calculated for each delineated drainage basin using TR-55 equations. Time of Concentration (Tc) flow paths are shown in Figure 2 and corresponding calculations for each drainage basin are included in Appendix A. A time of concentration of 5 minutes, the minimum allowable, was applied to developed impervious areas.

Most of the study area is comprised of silt loam categorized in the hydrologic soil group (HSG) D. HSG D soils generally exhibit very slow infiltration rates when thoroughly wet. A small upland area is categorized as HSG C with low to moderate infiltration. A Curve Number (CN) of 98 was used for all impervious areas. The pervious areas were open space with good grass cover, thus a CN of 74 (HSG C) or 80 (HSG D) was used as applicable. A weighted pervious curve number was used for the one basin which contained a mix of both soil types. A weighted time of concentration was used in the XP-SWMM model for each drainage basin and the pervious area Tc calculations are included in Appendix A.

The basins downstream of the proposed project site are developed residential areas. Impervious percentages were estimated based on existing impervious surfaces captured in 2007 aerial imagery. Figure 1 shows that the Frog Pond (FP) Estates and Frog Pond Oaks development are currently agricultural with few homes, outbuildings, and driveways. Per the Frog Pond West Master Plan (Wilsonville, 2017), the area is primarily to be developed into a medium lot single family homes with some areas of small and large lot homes. The impervious percentage for the proposed developments were

calculated using the proposed site plans. Table 1 summarized the hydrologic inputs from each basin into the XP-SWMM model.

Table 1 Hydrologic Basin Information

Basin	Basin Area (ac)	Percent Impervious	Weighted Pervious CN	Weighted Tc (min)	XP-SWMM Node
FP Estates	4.36	43.3	80.0	13.45	C
FP Oaks *	8.98	56.6	78.4	14.37	C
FP Vista	1.17	58.0	80.0	12.43	C
FP Crossing	1.23	58.0	80.0	11.13	C
School	5.53	35.0	80.0	5.00	B
FP Ridge WC	6.86	58.0	80.0	11.85	C
FP Ridge P	4.25	63.5	80.0	10.95	1
FP Meadows WC	12.43	59.7	80.0	9.35	1
Stafford Meadows	12.45	44.0	80.0	12.85	1
2	5.84	60.0	80.0	5.00	2
3	5.89	60.0	80.0	7.72	3
4	11.87	60.0	80.0	15.08	4

* Soils in basin are 26% HSG C and all other soils are classified as HSG D.

Table 2 summarizes the 25-year peak flow rates in Willow Creek for proposed project conditions calculated in XP-SWMM.

Table 2 Peak 25-Year Flow Rates

Node	Contributing Basin Area (ac)	Proposed Flow Rate (cfs)
C	22.60	16.21
B	28.13	20.61
1	57.26	42.83
2	63.10	48.43
3	68.99	53.61
4	80.86	62.15

Conveyance Modeling

The stormwater conveyance network was analyzed in XP-SWMM. The conveyance system was modeled to determine whether the existing downstream system has sufficient capacity to support the Frog Pond Estates and Frog Pond Oaks developments runoff undetained during the 25-year, 24-hour storm event. The pipe network reflects inverts from GIS As-built data. A pair of 18-inch diameter culverts convey Willow Creek beneath SW Boeckman Road (see Image 2). These culverts are approximately 80 feet long and invert elevations were obtained through survey. The open channel section and downstream pipe system were shown to have capacity for the developed flow rates. While the 25-yr event would not be conveyed across the crown of SW Boeckman Road, the headwater at the SW Boeckman culverts would spill onto the roadway at the low point. Appendix B includes output information from the XP-SWMM model, summarizing the pipe network characteristics and results of the hydraulic routing during the design storm.



Image 2 – Existing 18" Culverts under SW Boeckman Road

The hydraulic capacity of the existing SW Boeckman Road pair of 18-inch culverts, referred to as Culvert West and Culvert East, were also modeled using HY-8 software. The peak flow rate entering the culverts is the 29.73 cfs from the upstream channel (XP-SWMM Link 1) under proposed conditions. The results of the hydraulic calculations (see Appendix C) show that the existing culverts do not have adequate capacity to convey the 25-year flow rate without spilling onto the existing roadway. Replacing the culverts with a 2-ft wide by 3-ft tall box would be able to convey the design event with headwater elevation less than 1.5 times the diameter.

Conclusion

The conveyance capacity of Willow Creek was analyzed for approximately one quarter mile downstream of the proposed Frog Pond Estates and Frog Pond Oaks developments. The existing open channel and piped system was analyzed in XP-SWMM software. The capacity of the culverts under SW Boeckman Road were analyzed using HY-8 to determine that the 25-year event would spill onto the road surface. Rather than including onsite detention for all the upstream developments, it is preferable to replace existing culverts though it is undetermined when the culvert will be upsized.

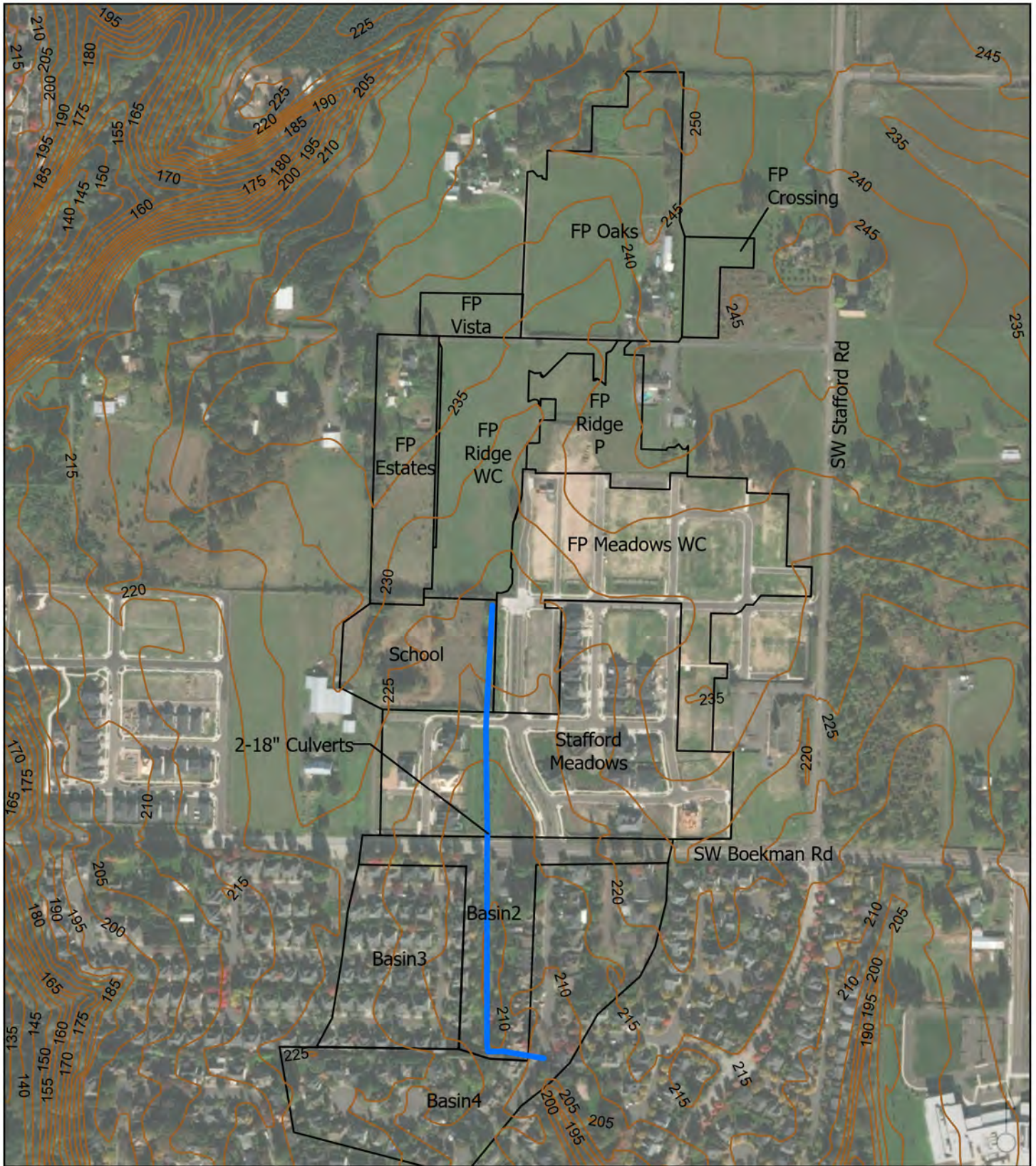

FIGURE 1
WILLOW CREEK DOWNSTREAM ANALYSIS
EXISTING CONDITIONS

FROG POND ESTATES AND FROG POND OAKS | PROJECT 20141
 WILSONVILLE, OREGON

Legend

- 5ft LiDAR Contours
- Extent of Downstream Analysis
- Analysis Drainage Basins

0 100 ft

Data Sources:
 Date: 10/11/2021
 Disclaimer: This data is not to survey accuracy and is meant for planning purposes only
 \\pdx-ae.otak.com\proj\Project\20100\20141\CADD\GIS\MXD\20141_DSAnalysis\Existing.aprx



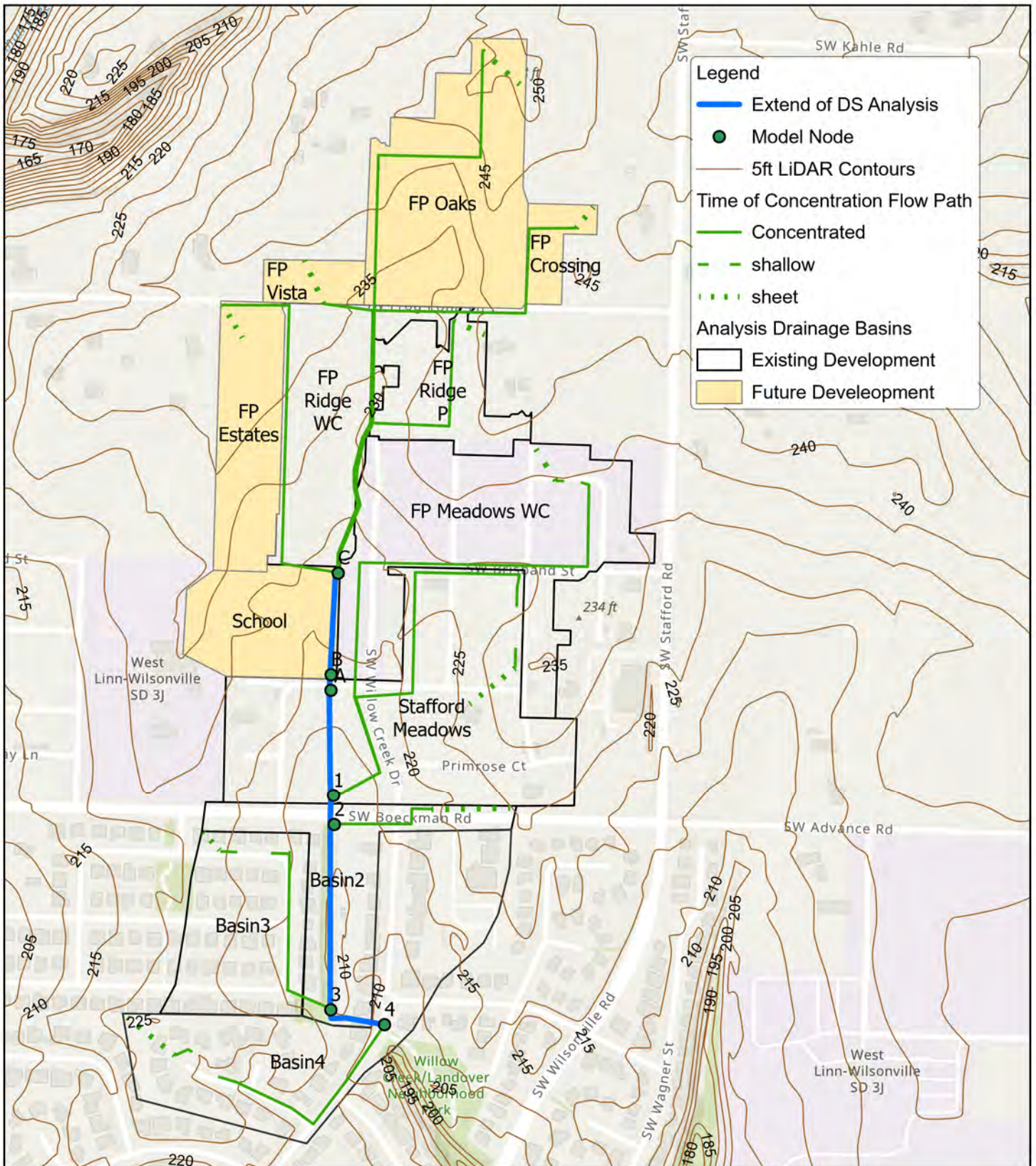

FIGURE 2
WILLOW CREEK DOWNSTREAM ANALYSIS
PROPOSED CONDITIONS

FROG POND ESTATES AND FROG POND OAKS | PROJECT 20141
 WILSONVILLE, OREGON

Data Sources:
 Date: 10/11/2021
 Disclaimer: This data is not to survey accuracy and is meant for planning purposes only
 \\pdx-ae.otak.com\proj\Project\20100\20141\CADD\GIS\MXD\20141_DSAnalysis.aprx



Time of Concentration Calculations

20141 Willow Creek Downstream Analysis

BASINS		2	3	4
SHEET FLOW				
INPUT				
Surface Description (from Table 3-1)		paved	short grass	Short grass
Manning's Roughness Coefficient		0.011	0.15	0.15
Flow Length, L (<300 ft)	ft	268	82	228
2-Year, 24-Hour Rainfall, P ₂	in	2.5	2.5	2.5
Land Slope, s	ft/ft	0.025	0.018	0.010
OUTPUT				
Travel Time	hr	0.05	0.16	0.48
SHALLOW CONCENTRATED FLOW				
INPUT				
Surface Description (paved or unpaved)		paved	paved	paved
Flow Length, L	ft	0	231	243
Watercourse Slope, s	ft/ft	0.000	0.011	0.029
OUTPUT				
Average Velocity, V	ft/s	0.00	2.16	3.45
Travel Time	hr	0.00	0.03	0.02
CHANNEL FLOW				
INPUT				
Cross Sectional Flow Area, a	ft ²	4.71	3.14	3.14
Wetted Perimeter, p _w	ft	1.77	0.79	0.79
Channel Slope, s	ft/ft	0.017	0.013	0.012
Manning's Roughness Coefficient		0.035	0.013	0.013
Flow Length, L	ft	373	471	700
OUTPUT				
Average Velocity, V	ft/s	10.79	33.00	31.69
Hydraulic Radius, r = a/p _w	ft	2.66	3.97	3.97
Travel Time	hr	0.010	0.004	0.006
Basin Time of Concentration, T_c	hrs	0.06	0.20	0.50
	min	3.3	11.8	30.2

Time of Concentration Calculations

20141 Willow Creek Downstream Analysis

BASINS		Stafford Meadows	FP Ridge	FP Meadows
SHEET FLOW				
INPUT				
Surface Description (from Table 3-1)		short grass	Short grass	short grass
Manning's Roughness Coefficient		0.15	0.15	0.15
Flow Length, L (<300 ft)	ft	120	115	115
2-Year, 24-Hour Rainfall, P ₂	in	2.5	2.5	2.5
Land Slope, s	ft/ft	0.010	0.011	0.022
OUTPUT				
Travel Time	hr	0.28	0.26	0.20
SHALLOW CONCENTRATED FLOW				
INPUT				
Surface Description (paved or unpaved)		paved	Unpaved	paved
Flow Length, L	ft	265	0.0001	120
Watercourse Slope, s	ft/ft	0.005	0.000	0.008
OUTPUT				
Average Velocity, V	ft/s	1.42	0.05	1.86
Travel Time	hr	0.05	0.00	0.02
CHANNEL FLOW				
INPUT				
Cross Sectional Flow Area, a	ft ²	3.14	0.77	3.14
Wetted Perimeter, p _w	ft	0.79	2.64	0.79
Channel Slope, s	ft/ft	0.012	0.004	0.012
Manning's Roughness Coefficient		0.035	0.013	0.035
Flow Length, L	ft	1345	1150	1905
OUTPUT				
Average Velocity, V	ft/s	11.47	3.34	11.48
Hydraulic Radius, r = a/p _w	ft	3.97	0.29	3.97
Travel Time	hr	0.033	0.096	0.046
Basin Time of Concentration, T_c	hrs	0.37	0.36	0.26
	min	22.0	21.3	15.8

Time of Concentration Calculations

20141 Willow Creek Downstream Analysis

BASINS		FP Estates	FP Oaks	FP Vista	FP Crossing
SHEET FLOW					
INPUT					
Surface Description (from Table 3-1)		Short grass	Short grass	Short grass	Short grass
Manning's Roughness Coefficient		0.15	0.15	0.15	0.15
Flow Length, L (<300 ft)	ft	130	170	165	90
2-Year, 24-Hour Rainfall, P ₂	in	2.5	2.5	2.5	2.5
Land Slope, s	ft/ft	0.021	0.013	0.013	0.020
OUTPUT					
Travel Time	hr	0.22	0.34	0.32	0.17
SHALLOW CONCENTRATED FLOW					
INPUT					
Surface Description (paved or unpaved)		Unpaved	Unpaved	Unpaved	Unpaved
Flow Length, L	ft	0.0001	0.0001	0.0001	0.0001
Watercourse Slope, s	ft/ft	0.000	0.000	0.000	0.000
OUTPUT					
Average Velocity, V	ft/s	0.05	0.05	0.05	0.05
Travel Time	hr	0.00	0.00	0.00	0.00
CHANNEL FLOW					
INPUT					
Cross Sectional Flow Area, a	ft ²	0.77	0.77	0.77	0.77
Wetted Perimeter, p _w	ft	2.64	2.64	2.64	2.64
Channel Slope, s	ft/ft	0.004	0.012	0.012	0.004
Manning's Roughness Coefficient		0.013	0.013	0.013	0.013
Flow Length, L	ft	1295	2155	1085	1880
OUTPUT					
Average Velocity, V	ft/s	3.34	5.57	5.57	3.34
Hydraulic Radius, r = a/p _w	ft	0.29	0.29	0.29	0.29
Travel Time	hr	0.108	0.108	0.054	0.156
Basin Time of Concentration, T_c	hrs	0.33	0.44	0.38	0.33
	min	19.9	26.6	22.7	19.6

XP-SWMM Layout

Willow Creek Downstream Analysis

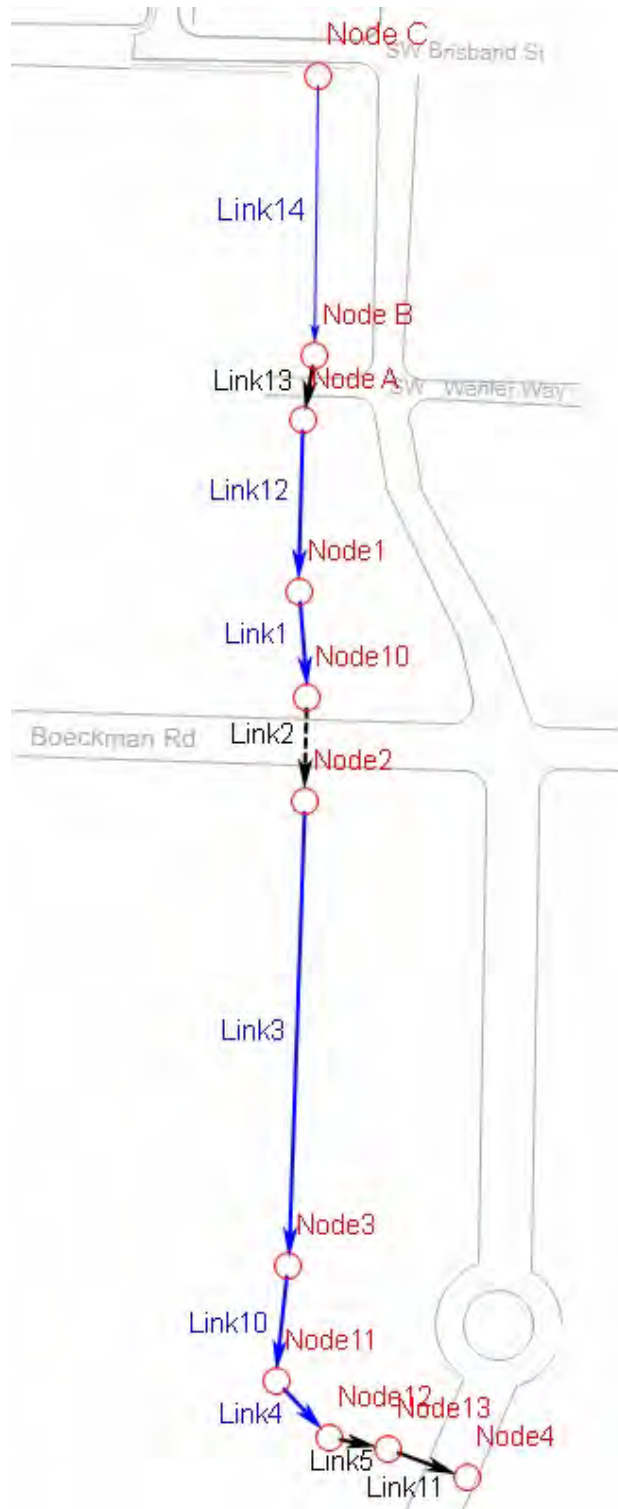

XP-SWMM RUNOFF DATA
Willow Creek Downstream Analysis
Proposed Conditions

SCS Type IA 25-Year Storm Event							
XP-SWMM Input Data					XP-SWMM Output Data		
Node Name	Total Area (ac)	Impervious %	Pervious Curve Number	Tc (min)	Rainfall Depth (in)	Unit Hydrograph Method	Surface Runoff Flow (cfs)
Node B	5.53	35	80	5.00	3.9	Santa Barbara	4.40
Node C	8.98	56.6	78.44	14.37	3.9	Santa Barbara	6.23
Node C	4.36	43.3	80	13.45	3.9	Santa Barbara	2.87
Node C	1.23	58	80	11.13	3.9	Santa Barbara	0.96
Node C	1.17	58	80	12.43	3.9	Santa Barbara	0.88
Node C	6.86	58	80	11.85	3.9	Santa Barbara	5.26
Node1	12.45	44	80	12.85	3.9	Santa Barbara	8.37
Node1	4.25	63.5	80	10.95	3.9	Santa Barbara	3.48
Node1	12.43	59.7	80	9.35	3.9	Santa Barbara	10.38
Node2	5.84	60	80	5.00	3.9	Santa Barbara	5.60
Node3	5.89	60	80	7.72	3.9	Santa Barbara	5.18
Node4	11.87	60	80	15.08	3.9	Santa Barbara	8.53

XP-SWMM HYDRAULICS DATA
Willow Creek Downstream Analysis
Proposed Conditions

SCS Type IA 25-Year Storm Event																					
Location			Conduit Properties					Conduit Profile								Conduit Results					
Link Name	Node Limits		Diameter		Length	Slope	Conduit Type	Ground Elevation (ft)		Invert Elevation (ft)		Max. Water Elevation (ft)		Freeboard (ft)		Design Flow	Max. Flow	Max. Velocity	Design Velocity	Max. Depth	y/d0
	From	To	in	ft	ft	%		US	DS	US	DS	US	DS	US	DS	(cfs)	(cfs)	(ft/s)	(ft/s)	(ft)	
Link1	Node1	Node10	18	1.50	35.00	0.2	channel	216.20	216.00	212.70	212.63	215.29	215.28	0.91	0.72	23.78	29.73	1.95	1.67	2.65	1.00
Link2	Node10	Node2	18	1.50	80.00	2.0	culvert	216.00	214.50	212.63	211.00	215.28	212.02	0.72	2.48	14.99	14.80	8.58	8.48	2.65	1.77
Link2	Node10	Node2	18	1.50	80.00	2.0	culvert	216.00	214.50	212.64	211.06	215.28	212.02	0.72	2.48	14.76	14.88	8.48	8.35	2.64	1.76
Link3	Node2	Node3	24	2.00	540.00	1.2	weir	214.50	209.00	211.00	204.40	212.02	205.15	2.48	3.85	152.09	32.68	3.30	5.43	1.02	0.51
Link4	Node11	Node12	48	4.00	15.00	3.3	channel	208.00	207.60	203.10	202.60	203.78	203.77	4.22	3.83	1736.29	37.25	3.78	16.38	1.17	0.29
Link5	Node12	Node13	36	3.00	32.00	3.9	culvert	207.60	206.00	202.52	201.27	203.77	202.37	3.83	3.63	131.82	37.25	13.64	18.65	1.25	0.42
Link10	Node3	Node11	48	4.00	110.00	1.2	channel	209.00	208.00	204.40	203.10	205.15	203.78	3.85	4.22	1033.85	37.25	3.74	9.75	0.75	0.19
Link11	Node13	Node4	36	3.00	144.00	3.9	channel	206.00	206.00	200.97	195.31	202.37	196.19	3.63	9.81	132.23	37.25	11.84	18.71	1.40	0.47
Link12	Node A	Node1	26	2.20	360.00	1.0	channel	224.50	216.20	216.15	212.70	217.15	215.29	7.35	0.91	344.23	19.48	1.79	3.91	2.59	1.18
Link13	Node B	Node A	36	3.00	35.03	1.1	culvert	225.00	224.50	216.53	216.15	217.45	217.15	7.55	7.35	88.45	20.30	7.33	9.83	1.00	0.33
Link14	Node C	Node B	24	2.00	360.00	1.5	channel	224.00	225.00	221.96	216.53	222.77	217.45	1.23	7.55	127.47	16.10	3.19	5.54	0.92	0.46

HY-8 Culvert Analysis Report

Tailwater Channel Data - SW Boeckman Road

Tailwater Channel Option: Trapezoidal Channel

Bottom Width: 6.00 ft

Side Slope (H:V): 4.00 (4:1)

Channel Slope: 0.0120

Channel Manning's n: 0.0350

Channel Invert Elevation: 211.00 ft

Roadway Data for Crossing: SW Boeckman Road

Roadway Profile Shape: Irregular Roadway Shape (coordinates)

Roadway Surface: Paved

Roadway Top Width: 68.00 ft

Crossing Discharge Data

Discharge Selection Method: Specify Minimum, Design, and Maximum Flow

Minimum Flow: 20 cfs

Design Flow: 29.83 cfs

Maximum Flow: 33 cfs

Table 1 - Downstream Channel Rating Curve (Crossing: SW Boeckman Road)

Flow (cfs)	Water Surface Elev (ft)	Depth (ft)	Velocity (ft/s)	Shear (psf)	Froude Number
20.00	211.73	0.73	3.09	0.54	0.73
21.30	211.75	0.75	3.14	0.56	0.74
22.60	211.78	0.78	3.20	0.58	0.74
23.90	211.80	0.80	3.25	0.60	0.74
25.20	211.82	0.82	3.30	0.62	0.75
26.50	211.84	0.84	3.35	0.63	0.75
27.80	211.87	0.87	3.39	0.65	0.75
29.10	211.89	0.89	3.44	0.66	0.75
29.83	211.90	0.90	3.46	0.67	0.75
31.70	211.93	0.93	3.52	0.69	0.76
33.00	211.95	0.95	3.56	0.71	0.76

Table 2 - Summary of Culvert Flows at Crossing: SW Boeckman Road

Headwater Elevation (ft)	Total Discharge (cfs)	Culvert West Discharge (cfs)	Culvert East Discharge (cfs)	Roadway Discharge (cfs)	Iterations
215.19	20.00	10.02	9.99	0.00	6
215.41	21.30	10.64	10.61	0.00	26
215.63	22.60	11.28	11.25	0.00	34
215.77	23.90	11.65	11.63	0.53	18
215.82	25.20	11.78	11.76	1.58	9
215.85	26.50	11.87	11.84	2.71	7
215.88	27.80	11.94	11.91	3.88	6
215.90	29.10	11.99	11.97	5.05	5
215.91	29.83	12.02	12.00	5.72	4
215.94	31.70	12.09	12.06	7.49	5
215.95	33.00	12.13	12.10	8.69	4
215.69	22.84	11.43	11.41	0.00	Overtopping

Table 3 - Culvert Summary Table: Culvert West

Total Discharge (cfs)	Culvert Discharge (cfs)	Headwater Elevation (ft)	Inlet Control Depth (ft)	Outlet Control Depth (ft)	Flow Type	Normal Depth (ft)	Critical Depth (ft)	Outlet Depth (ft)	Tailwater Depth (ft)	Outlet Velocity (ft/s)	Tailwater Velocity (ft/s)
20.00	10.02	215.19	2.563	1.292	5-S2n	0.892	1.218	0.907	0.728	8.973	3.085
21.30	10.64	215.41	2.774	1.509	5-S2n	0.928	1.252	0.944	0.752	9.085	3.142
22.60	11.28	215.63	3.003	1.743	5-S2n	0.966	1.283	0.983	0.776	9.187	3.197
23.90	11.65	215.77	3.142	1.885	5-S2n	0.990	1.299	1.005	0.800	9.272	3.249
25.20	11.78	215.82	3.190	1.935	5-S2n	0.997	1.305	1.013	0.822	9.292	3.299
26.50	11.87	215.85	3.222	1.968	5-S2n	1.003	1.309	1.018	0.844	9.307	3.348
27.80	11.94	215.88	3.248	1.995	5-S2n	1.007	1.311	1.022	0.866	9.320	3.394
29.10	11.99	215.90	3.270	2.017	5-S2n	1.011	1.314	1.025	0.886	9.331	3.439
29.83	12.02	215.91	3.281	2.028	5-S2n	1.012	1.315	1.027	0.898	9.337	3.463
31.70	12.09	215.94	3.306	2.055	5-S2n	1.016	1.318	1.031	0.927	9.351	3.524
33.00	12.13	215.95	3.322	2.071	5-S2n	1.019	1.319	1.033	0.946	9.360	3.564

Table 4 - Culvert Summary Table: Culvert East

Total Discharge (cfs)	Culvert Discharge (cfs)	Headwater Elevation (ft)	Inlet Control Depth (ft)	Outlet Control Depth (ft)	Flow Type	Normal Depth (ft)	Critical Depth (ft)	Outlet Depth (ft)	Tailwater Depth (ft)	Outlet Velocity (ft/s)	Tailwater Velocity (ft/s)
20.00	9.99	215.19	2.553	1.331	5-S2n	0.899	1.217	0.913	0.728	8.872	3.085
21.30	10.61	215.41	2.764	1.548	5-S2n	0.936	1.250	0.951	0.752	8.982	3.142
22.60	11.25	215.63	2.993	1.782	5-S2n	0.975	1.281	0.990	0.776	9.082	3.197
23.90	11.63	215.77	3.132	1.924	5-S2n	0.999	1.298	1.012	0.800	9.182	3.249
25.20	11.76	215.82	3.180	1.973	5-S2n	1.007	1.304	1.020	0.822	9.198	3.299
26.50	11.84	215.85	3.212	2.007	5-S2n	1.012	1.307	1.026	0.844	9.207	3.348
27.80	11.91	215.88	3.238	2.033	5-S2n	1.016	1.310	1.031	0.866	9.215	3.394
29.10	11.97	215.90	3.260	2.056	5-S2n	1.020	1.313	1.034	0.886	9.222	3.439
29.83	12.00	215.91	3.271	2.067	5-S2n	1.022	1.314	1.036	0.898	9.226	3.463
31.70	12.06	215.94	3.296	2.093	5-S2n	1.026	1.317	1.040	0.927	9.235	3.524
33.00	12.10	215.95	3.312	2.109	5-S2n	1.029	1.318	1.043	0.946	9.240	3.564

Water Surface Profile Plot for Culvert: Culvert West

Crossing - SW Boeckman Road, Design Discharge - 29.8 cfs

Culvert - Culvert West, Culvert Discharge - 12.0 cfs

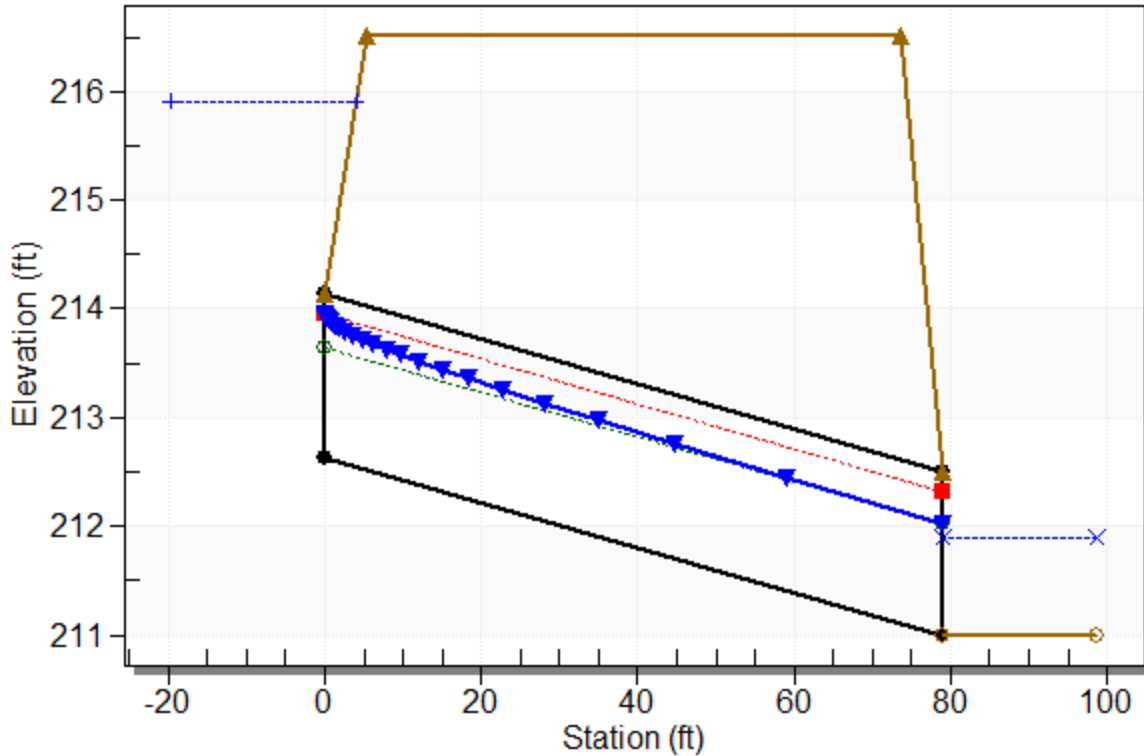

Straight Culvert

Inlet Elevation (invert): 212.63 ft, Outlet Elevation (invert): 211.00 ft

Culvert Length: 79.03 ft, Culvert Slope: 0.0206

Culvert Data Summary - Culvert West

- Barrel Shape: Circular
- Barrel Diameter: 1.50 ft
- Barrel Material: Concrete
- Embedment: 0.00 in
- Barrel Manning's n: 0.0130
- Culvert Type: Straight
- Inlet Configuration: Mitered to Conform to Slope
- Inlet Depression: NONE

Site Data - Culvert West

- Site Data Option: Culvert Invert Data
- Inlet Station: 0.00 ft
- Inlet Elevation: 212.63 ft
- Outlet Station: 79.01 ft
- Outlet Elevation: 211.00 ft

Water Surface Profile Plot for Culvert: Culvert East

Crossing - SW Boeckman Road, Design Discharge - 29.8 cfs

Culvert - Culvert East, Culvert Discharge - 12.0 cfs

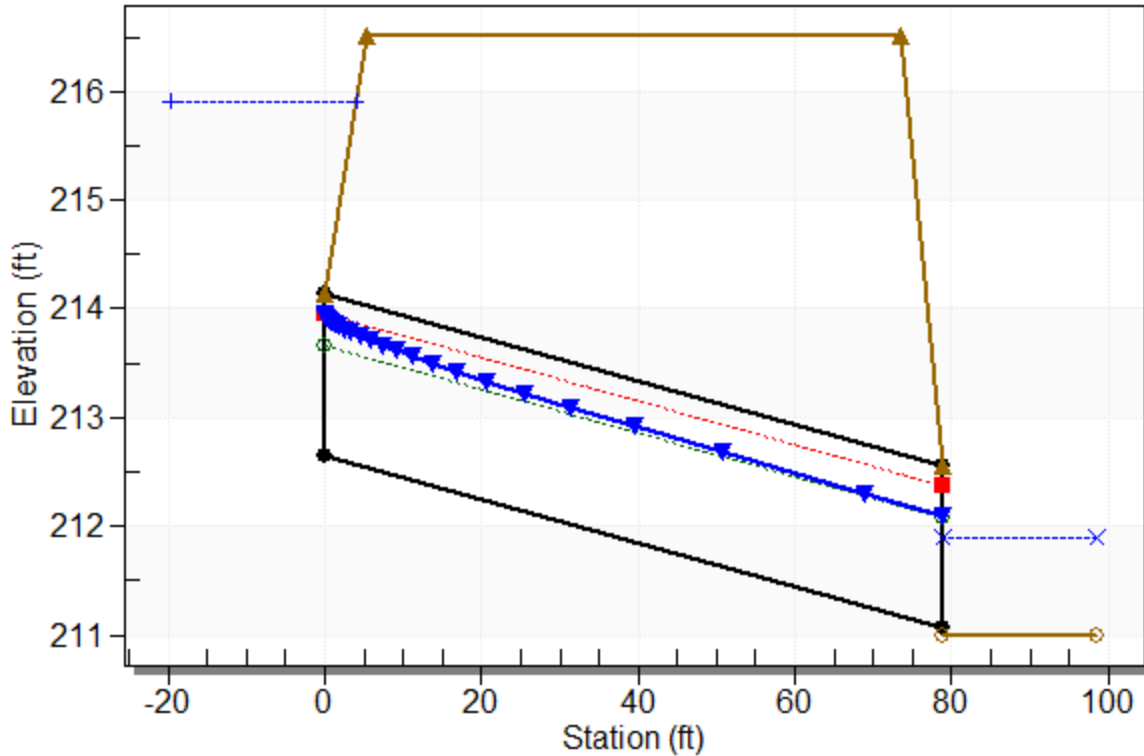

Straight Culvert
Inlet Elevation (invert): 212.64 ft, Outlet Elevation (invert): 211.06 ft
Culvert Length: 78.89 ft, Culvert Slope: 0.0200

Culvert Data Summary - Culvert East

- Barrel Shape: Circular
- Barrel Diameter: 1.50 ft
- Barrel Material: Concrete
- Embedment: 0.00 in
- Barrel Manning's n: 0.0130
- Culvert Type: Straight
- Inlet Configuration: Mitered to Conform to Slope
- Inlet Depression: NONE

Site Data - Culvert East

- Site Data Option: Culvert Invert Data
- Inlet Station: 0.00 ft
- Inlet Elevation: 212.64 ft
- Outlet Station: 78.87 ft
- Outlet Elevation: 211.06 ft

Table 5 - Downstream Channel Rating Curve (Crossing: SW Boeckman Road)

Flow (cfs)	Water Surface Elev (ft)	Depth (ft)	Velocity (ft/s)	Shear (psf)	Froude Number
20.00	211.73	0.73	3.09	0.54	0.73
21.30	211.75	0.75	3.14	0.56	0.74
22.60	211.78	0.78	3.20	0.58	0.74
23.90	211.80	0.80	3.25	0.60	0.74
25.20	211.82	0.82	3.30	0.62	0.75
26.50	211.84	0.84	3.35	0.63	0.75
27.80	211.87	0.87	3.39	0.65	0.75
29.10	211.89	0.89	3.44	0.66	0.75
29.83	211.90	0.90	3.46	0.67	0.75
31.70	211.93	0.93	3.52	0.69	0.76
33.00	211.95	0.95	3.56	0.71	0.76

Tailwater Channel Data - SW Boeckman Road Improve

Tailwater Channel Option: Trapezoidal Channel

Bottom Width: 6.00 ft

Side Slope (H:V): 4.00 (_:1)

Channel Slope: 0.0120

Channel Manning's n: 0.0350

Channel Invert Elevation: 211.00 ft

Roadway Data for Crossing: SW Boeckman Road Improve

Roadway Profile Shape: Irregular Roadway Shape (coordinates)

Roadway Surface: Paved

Roadway Top Width: 68.00 ft

Crossing Discharge Data

Discharge Selection Method: Specify Minimum, Design, and Maximum Flow

Minimum Flow: 20 cfs

Design Flow: 29.83 cfs

Maximum Flow: 33 cfs

Table 6 - Summary of Culvert Flows at Crossing: SW Boeckman Road Improve

Headwater Elevation (ft)	Total Discharge (cfs)	2H x3W Box Discharge (cfs)	Roadway Discharge (cfs)	Iterations
214.47	20.00	20.00	0.00	1
214.55	21.30	21.30	0.00	1
214.63	22.60	22.60	0.00	1
214.72	23.90	23.90	0.00	1
214.80	25.20	25.20	0.00	1
214.89	26.50	26.50	0.00	1
214.98	27.80	27.80	0.00	1
215.07	29.10	29.10	0.00	1
215.12	29.83	29.83	0.00	1
215.25	31.70	31.70	0.00	1
215.35	33.00	33.00	0.00	1
215.69	37.24	37.24	0.00	Overtopping

Table 7 - Culvert Summary Table: 2H x3W Box

Total Discharge (cfs)	Culvert Discharge (cfs)	Headwater Elevation (ft)	Inlet Control Depth (ft)	Outlet Control Depth (ft)	Flow Type	Normal Depth (ft)	Critical Depth (ft)	Outlet Depth (ft)	Tailwater Depth (ft)	Outlet Velocity (ft/s)	Tailwater Velocity (ft/s)
20.00	20.00	214.47	1.865	0.0*	1-S2n	0.677	1.113	0.710	0.728	9.390	3.085
21.30	21.30	214.55	1.949	0.004	1-S2n	0.708	1.161	0.742	0.752	9.571	3.142
22.60	22.60	214.63	2.033	0.107	5-S2n	0.738	1.208	0.767	0.776	9.817	3.197
23.90	23.90	214.72	2.118	0.212	5-S2n	0.767	1.254	0.802	0.800	9.934	3.249
25.20	25.20	214.80	2.203	0.319	5-S2n	0.795	1.299	0.837	0.822	10.033	3.299
26.50	26.50	214.89	2.290	0.429	5-S2n	0.823	1.343	0.867	0.844	10.189	3.348
27.80	27.80	214.98	2.378	0.542	5-S2n	0.852	1.387	0.893	0.866	10.374	3.394
29.10	29.10	215.07	2.468	0.657	5-S2n	0.880	1.430	0.926	0.886	10.471	3.439
29.83	29.83	215.12	2.519	0.723	5-S2n	0.896	1.453	0.946	0.898	10.514	3.463
31.70	31.70	215.25	2.655	1.139	5-S2n	0.935	1.514	0.990	0.927	10.673	3.524
33.00	33.00	215.35	2.752	1.241	5-S2n	0.962	1.555	1.018	0.946	10.808	3.564

* Full Flow Headwater elevation is below inlet invert.

Water Surface Profile Plot for Culvert: 2H x3W Box

Crossing - SW Boeckman Road Improve, Design Discharge - 29.8 cfs
 Culvert - 2H x3W Box, Culvert Discharge - 29.8 cfs

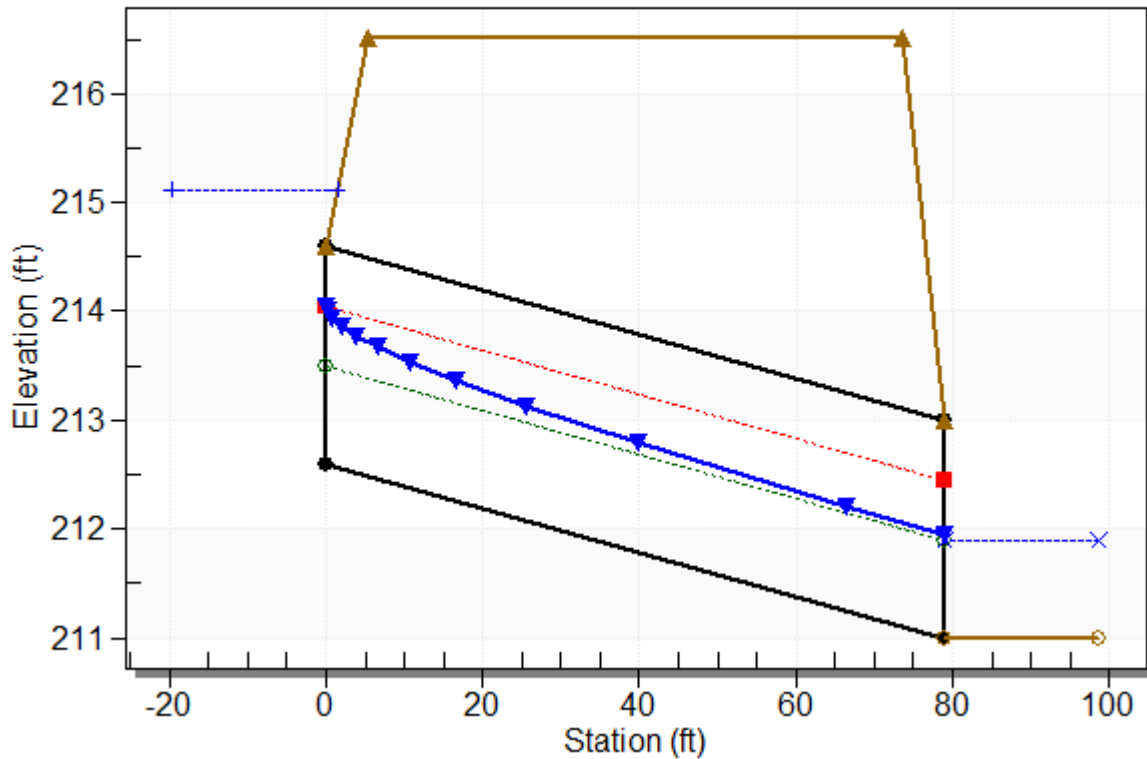

Straight Culvert
Inlet Elevation (invert): 212.60 ft, Outlet Elevation (invert): 211.00 ft
Culvert Length: 79.02 ft, Culvert Slope: 0.0203

Culvert Data Summary - 2H x3W Box

Barrel Shape: Concrete Box
Barrel Span: 3.00 ft
Barrel Rise: 2.00 ft
Barrel Material: Concrete
Embedment: 0.00 in
Barrel Manning's n: 0.0130
Culvert Type: Straight
Inlet Configuration: Square Edge (90°) Headwall
Inlet Depression: NONE

Site Data - 2H x3W Box

Site Data Option: Culvert Invert Data
Inlet Station: 0.00 ft
Inlet Elevation: 212.60 ft
Outlet Station: 79.00 ft
Outlet Elevation: 211.00 ft
Number of Barrels: 1

XP-SWMM Layout
Frog Pond Ridge
Proposed Conditions – Willow Creek Basin

Anticipated Frog Pond
Oaks connection

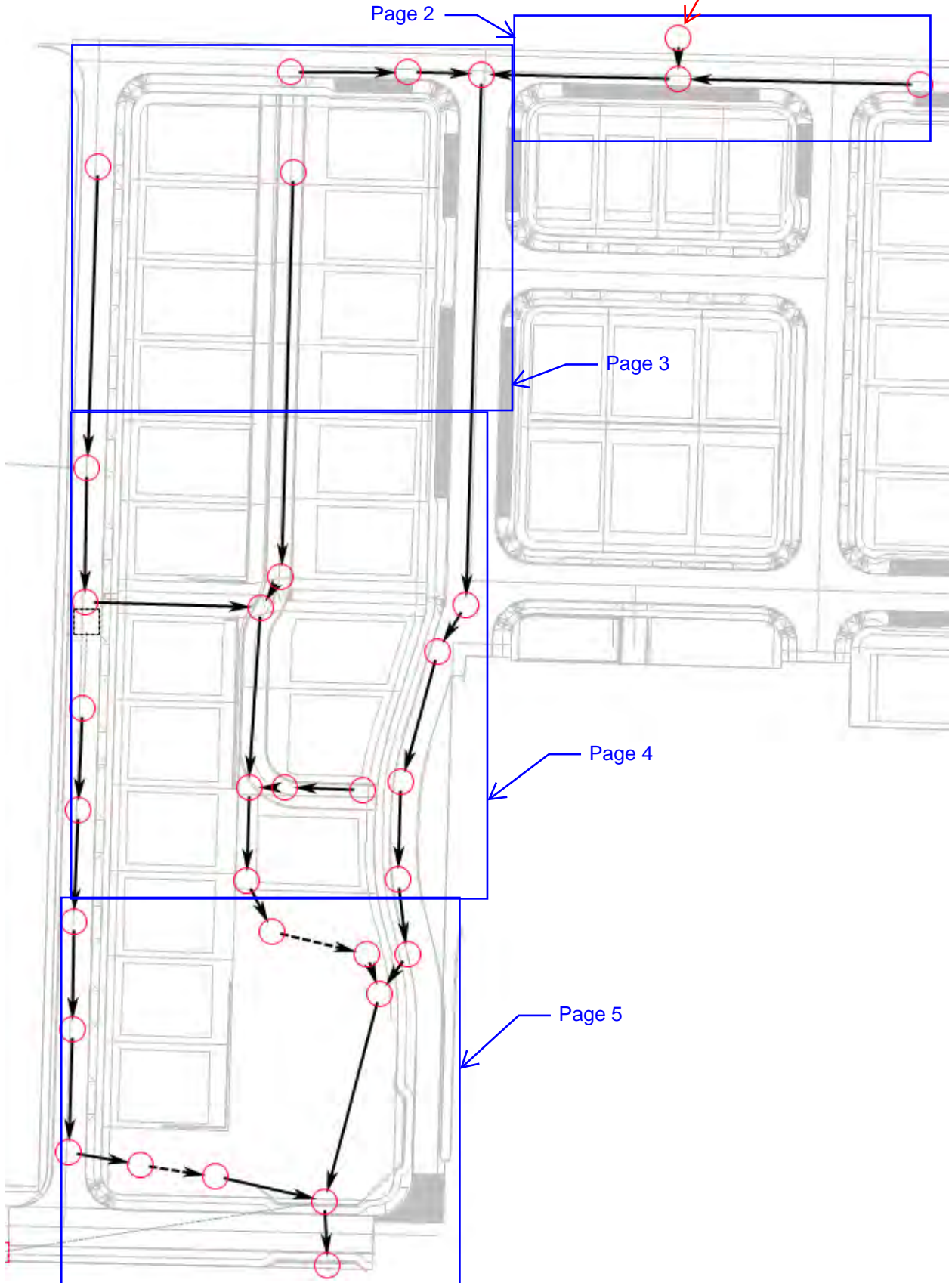

XP-SWMM Layout
Frog Pond Ridge
Proposed Conditions – Willow Creek Basin

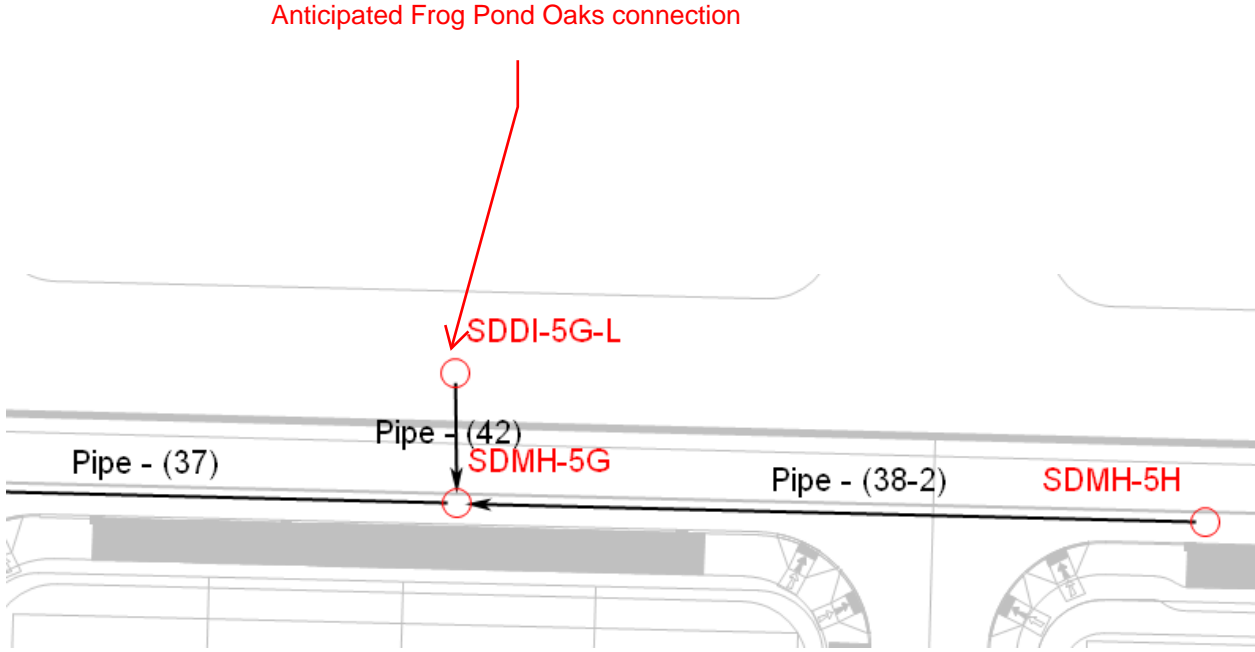

XP-SWMM Layout
Frog Pond Ridge
Proposed Conditions – Willow Creek Basin

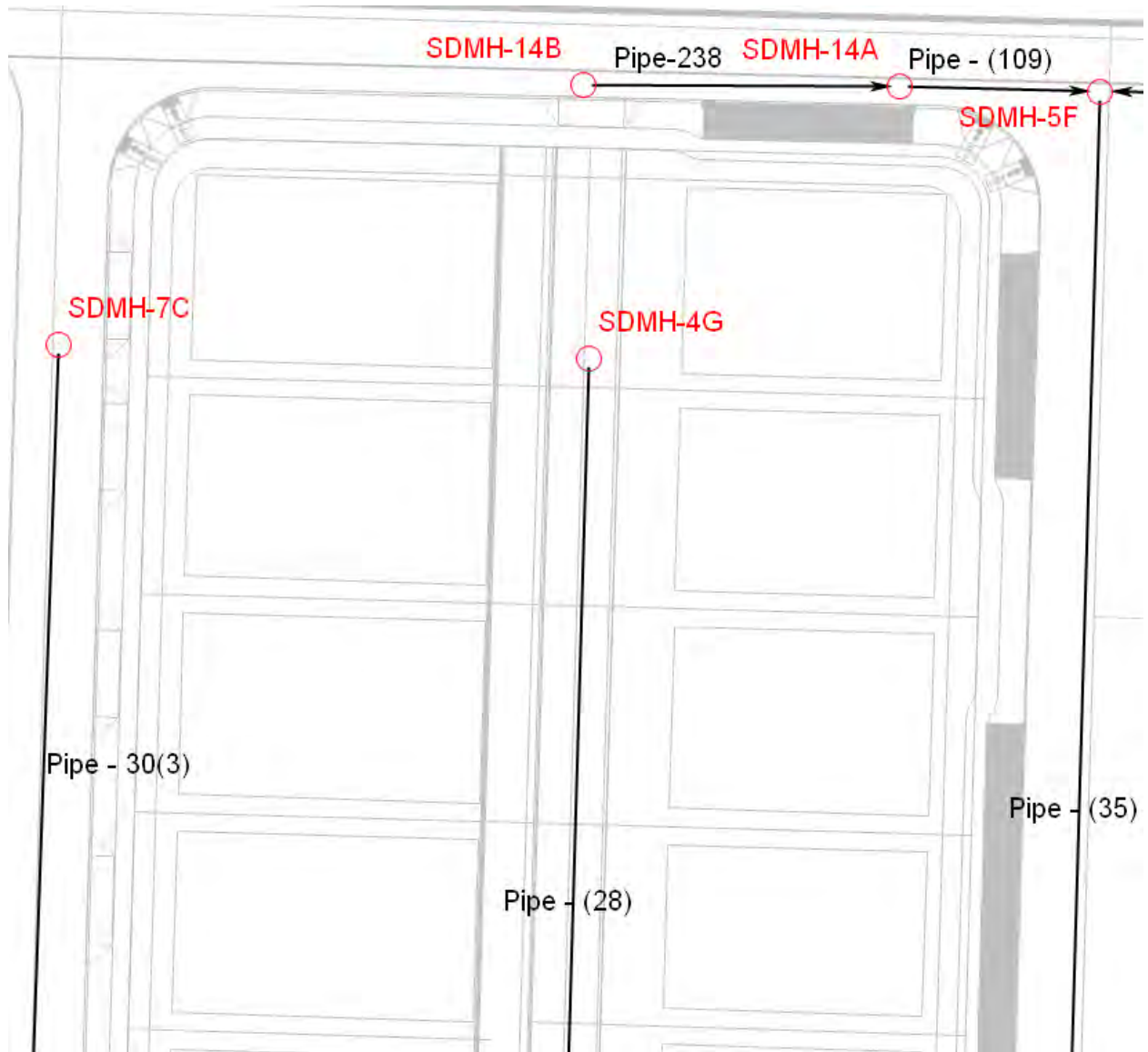

XP-SWMM Layout
Frog Pond Ridge
Proposed Conditions – Willow Creek Basin

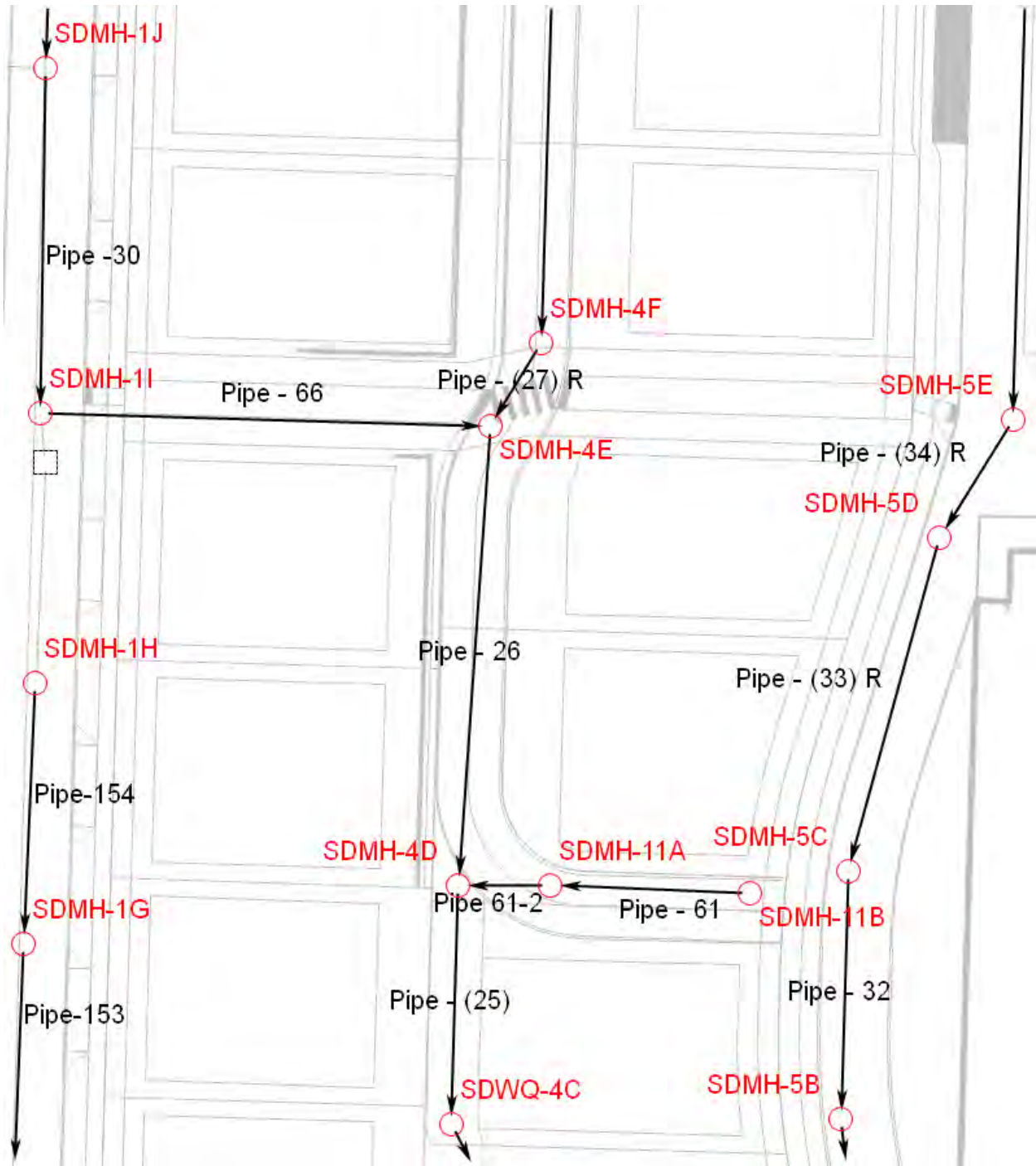

XP-SWMM Layout
Frog Pond Ridge
Proposed Conditions – Willow Creek Basin

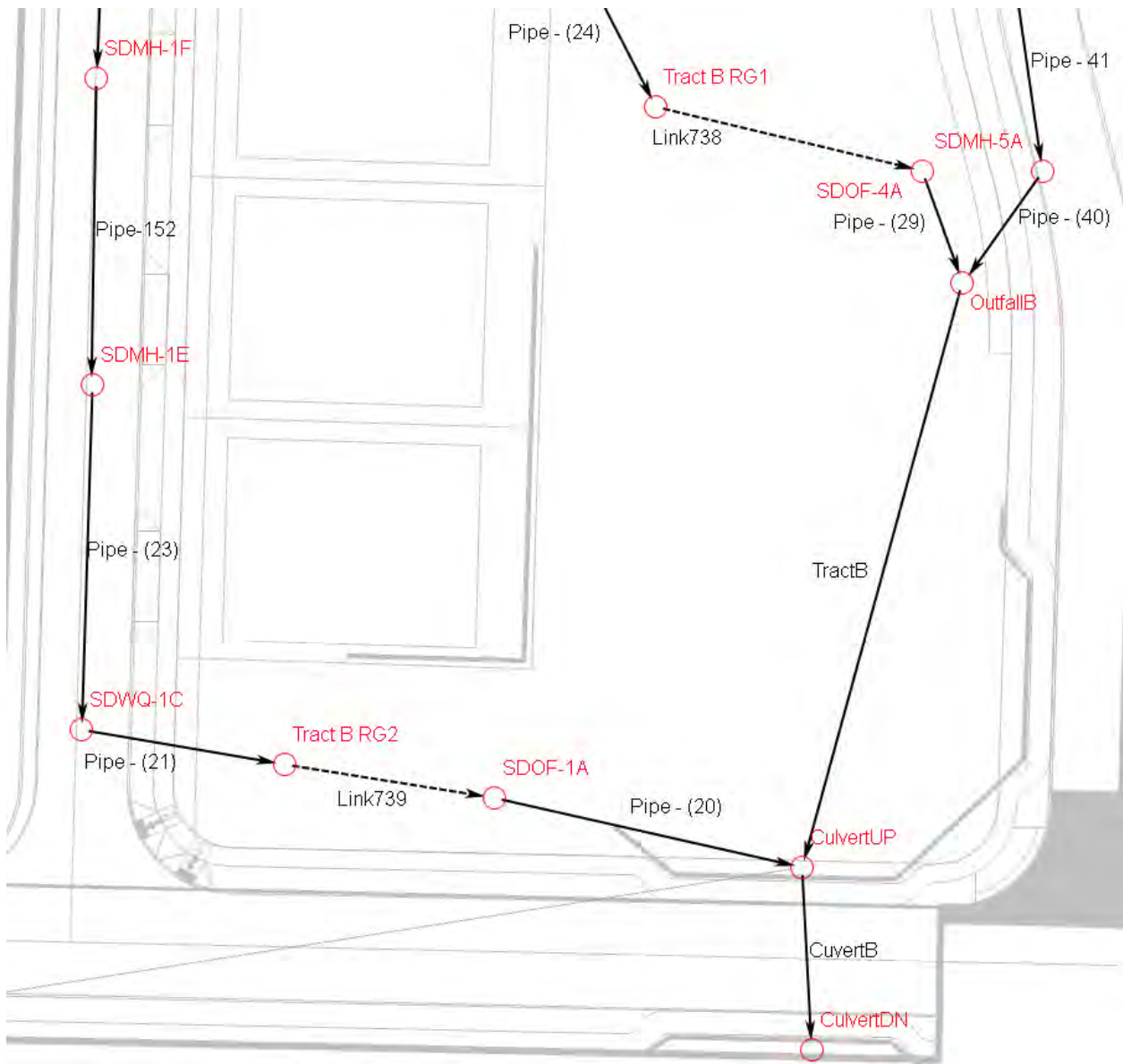

XP-SWMM RUNOFF DATA

Frog Pond Ridge

Proposed Conditions - Willow Creek Basin

Anticipated Frog Pond Oaks contribution

SCS Type IA 25-Year Storm Event							
XP-SWMM Input Data					XP-SWMM Output Data		
Node Name	Total Area (ac)	Impervious %	Curve Number	Tc (min)	Rainfall Depth (in)	Unit Hydrograph Method	Surface Runoff Flow (cfs)
CulvertUP	0.43	0	80	5	3.9	Santa Barbara	0.25
SDMH-5H	0.28	100	98	5	3.9	Santa Barbara	0.33
SDMH-5H	0.11	0	80	5	3.9	Santa Barbara	0.06
SDMH-7C	0.43	100	98	5	3.9	Santa Barbara	0.50
SDMH-7C	0.27	0	80	5	3.9	Santa Barbara	0.16
SDMH-4G	0.57	100	98	5	3.9	Santa Barbara	0.67
SDMH-4G	0.46	0	80	5	3.9	Santa Barbara	0.27
SDMH-14A	0.09	100	98	5	3.9	Santa Barbara	0.11
SDMH-14A	0.03	0	80	5	3.9	Santa Barbara	0.02
SDMH-5F	0.45	100	98	5	3.9	Santa Barbara	0.53
SDMH-5F	0.24	0	80	5	3.9	Santa Barbara	0.14
SDMH-5G	0.33	100	98	5	3.9	Santa Barbara	0.39
SDMH-5G	0.06	0	80	5	3.9	Santa Barbara	0.04
SDMH-1I	0.20	100	98	5	3.9	Santa Barbara	0.24
SDDI-5G-L	10.31	100	98	5	3.9	Santa Barbara	12.09
SDDI-5G-L	7.17	0	80	5	3.9	Santa Barbara	4.14
SDWQ-4C	0.13	100	98	5	3.9	Santa Barbara	0.15
SDMH-11B	0.17	100	98	5	3.9	Santa Barbara	0.20
SDMH-11B	0.27	0	80	5	3.9	Santa Barbara	0.16
SDMH-1E	0.22	100	98	5	3.9	Santa Barbara	0.26
SDMH-1E	0.14	0	80	5	3.9	Santa Barbara	0.08
SDWQ-1C	0.10	100	98	5	3.9	Santa Barbara	0.12
SDMH-1J	0.19	100	98	5	3.9	Santa Barbara	0.22
SDMH-1J	0.14	0	80	5	3.9	Santa Barbara	0.08
SDMH-11A	0.15	100	98	5	3.9	Santa Barbara	0.18
SDMH-11A	0.16	0	80	5	3.9	Santa Barbara	0.09
SDMH-1H	0.12	100	98	5	3.9	Santa Barbara	0.14

XP-SWMM RUNOFF DATA
Frog Pond Ridge
Proposed Conditions - Willow Creek Basin

SCS Type IA 25-Year Storm Event							
XP-SWMM Input Data					XP-SWMM Output Data		
Node Name	Total Area (ac)	Impervious %	Curve Number	Tc (min)	Rainfall Depth (in)	Unit Hydrograph Method	Surface Runoff Flow (cfs)
SDMH-1H	0.07	0	80	5	3.9	Santa Barbara	0.04
SDMH-1F	0.19	100	98	5	3.9	Santa Barbara	0.22
SDMH-1F	0.20	0	80	5	3.9	Santa Barbara	0.12
SDMH-14B	0.07	100	98	5	3.9	Santa Barbara	0.08
SDMH-14B	0.03	0	80	5	3.9	Santa Barbara	0.02

XP-SWMM HYDRAULICS DATA
Frog Pond Ridge
Proposed Conditions - Willow Creek Basin

SCS Type IA 25-Year Storm Event																					
Location			Conduit Properties					Conduit Profile								Conduit Results					
Link Name	Node Limits		Diameter		Length	Slope	Conduit Type	Ground Elevation (ft)		Invert Elevation (ft)		Max. Water Elevation (ft)		Freeboard (ft)		Design Flow	Max. Flow	Max. Velocity	Design Velocity	Max. Depth	y/d0
	From	To	in	ft	ft	%		US	DS	US	DS	US	DS	US	DS	(cfs)	(cfs)	(ft/s)	(ft/s)	(ft)	
CuvertB	CulvertUP	CulvertDN	30	2.50	48.18	0.1	pipe	229.00	229.00	222.03	221.96	224.55	224.40	4.45	4.60	15.63	21.82	4.44	3.19	2.52	1.01
Pipe - (38-2)	SDMH-5H	SDMH-5G	12	1.00	180.52	0.0	pipe	238.51	235.38	232.88	231.07	233.10	232.53	5.41	2.86	3.56	0.39	1.98	4.54	1.46	1.46
Pipe - 30(3)	SDMH-7C	SDMH-1J	12	1.00	218.86	0.4	pipe	237.47	234.82	232.22	231.26	232.59	231.51	4.88	3.31	2.36	0.65	2.51	3.00	0.37	0.37
Pipe - (28)	SDMH-4G	SDMH-4F	12	1.00	302.18	0.4	pipe	237.19	233.32	231.46	230.13	231.90	230.45	5.29	2.87	2.36	0.91	2.75	3.01	0.44	0.44
Pipe - (109)	SDMH-14A	SDMH-5F	12	1.00	55.31	1.0	pipe	236.71	236.04	230.57	230.02	231.77	231.77	4.94	4.28	3.55	0.65	1.93	4.52	1.75	1.75
Pipe - (35)	SDMH-5F	SDMH-5E	24	2.00	398.00	0.3	pipe	236.04	234.97	229.02	227.83	231.77	229.43	4.28	5.54	12.39	17.51	5.64	3.94	2.74	1.37
Pipe - (37)	SDMH-5G	SDMH-5F	24	2.00	148.36	0.6	pipe	235.38	236.04	230.87	230.02	232.53	231.77	2.86	4.28	17.15	16.88	6.32	5.46	1.75	0.87
Pipe - (34) R	SDMH-5E	SDMH-5D	24	2.00	40.62	0.0	pipe	234.97	234.12	227.63	227.51	229.43	229.19	5.54	4.93	12.38	17.44	5.90	3.94	1.80	0.90
Pipe - (27) R	SDMH-4F	SDMH-4E	12	1.00	28.21	0.4	pipe	233.32	233.40	229.93	229.81	230.45	230.41	2.87	2.99	2.32	0.91	2.48	2.96	0.60	0.60
Pipe - 66	SDMH-1I	SDMH-4E	12	1.00	131.88	0.4	pipe	233.75	233.40	230.39	229.81	230.90	230.41	2.86	2.99	2.36	1.17	2.90	3.01	0.60	0.60
Pipe - 26	SDMH-4E	SDMH-4D	12	1.00	134.69	0.4	pipe	233.40	233.01	229.61	229.02	230.41	229.98	2.99	3.03	2.36	2.06	3.06	3.00	0.96	0.96
Pipe - (42)	SDDI-5G-L	SDMH-5G	18	1.50	29.82	3.0	pipe	234.61	235.38	231.97	231.07	233.21	232.53	1.40	2.86	18.25	16.21	10.48	10.32	1.46	0.97
Pipe - (25)	SDMH-4D	SDWQ-4C	12	1.00	69.93	0.4	pipe	233.01	233.11	228.82	228.51	229.98	229.63	3.03	3.48	2.37	2.63	3.19	3.02	1.16	1.16
Pipe - (33) R	SDMH-5D	SDMH-5C	24	2.00	101.43	0.0	pipe	234.12	232.60	227.31	227.01	229.19	228.58	4.93	4.02	12.39	17.43	5.79	3.94	1.87	0.94
Pipe - (24)	SDWQ-4C	Tract B RG1	12	1.00	16.10	0.4	pipe	233.11	229.60	228.31	228.24	229.63	229.54	3.48	0.07	2.35	2.77	3.51	2.99	1.32	1.32
Pipe - 61	SDMH-11B	SDMH-11A	12	1.00	67.24	0.4	pipe	233.09	232.42	229.60	229.30	230.00	229.98	3.09	2.44	2.38	0.34	1.75	3.03	0.68	0.68
Pipe - 32	SDMH-5C	SDMH-5B	24	2.00	72.69	0.0	pipe	232.60	231.54	226.81	226.59	228.58	228.11	4.02	3.42	12.39	17.43	6.00	3.94	1.77	0.89
Pipe - (23)	SDMH-1E	SDWQ-1C	12	1.00	83.30	0.4	pipe	231.61	230.80	227.97	227.43	228.91	228.87	2.70	1.93	2.87	0.85	1.10	3.65	1.44	1.44
Pipe - 41	SDMH-5B	SDMH-5A	24	2.00	56.99	0.0	pipe	231.54	230.71	226.39	226.22	228.11	227.73	3.42	2.98	12.38	17.43	6.13	3.94	1.72	0.86
Pipe - (21)	SDWQ-1C	Tract B RG2	12	1.00	38.00	0.4	pipe	230.80	230.00	227.23	227.06	228.87	228.85	1.93	1.15	2.38	0.96	1.22	3.03	1.79	1.79
Pipe - (40)	SDMH-5A	OutfallB	24	2.00	57.92	0.3	pipe	230.71	230.00	226.02	225.84	227.73	226.08	2.98	3.92	12.83	17.43	6.18	4.08	1.71	0.85
Pipe - (29)	SDOF-4A	OutfallB	12	1.00	16.43	0.4	pipe	229.60	230.00	225.91	225.84	226.69	226.08	2.91	3.92	2.33	2.76	4.26	2.96	0.78	0.78
Pipe - (20)	SDOF-1A	CulvertUP	12	1.00	49.00	0.4	pipe	229.30	229.00	225.18	224.99	225.64	224.55	3.66	4.45	2.25	0.96	2.80	2.87	0.45	0.45
Pipe -30	SDMH-1J	SDMH-1I	12	1.00	107.64	0.4	pipe	234.82	233.75	231.06	230.59	231.51	230.90	3.31	2.86	2.35	0.95	2.81	3.00	0.45	0.45
Link680	Future ThWoeK	CulvertUP	12	1.00	100.00	0.5	pipe	232.00	229.00	226.55	226.10	229.85	224.55	2.15	4.45	2.39	6.08	7.65	3.04	3.30	3.30
Pipe 61-2	SDMH-11A	SDMH-4D	12	1.00	17.96	0.4	pipe	232.42	233.01	229.10	229.02	229.98	229.98	2.44	3.03	2.38	0.58	0.95	3.03	0.96	0.96
Pipe-154	SDMH-1H	SDMH-1G	12	1.00	78.30	0.4	pipe	232.95	232.61	229.61	229.27	229.80	229.26	3.15	3.35	2.35	0.18	1.72	2.99	0.19	0.19
Pipe-153	SDMH-1G	SDMH-1F	12	1.00	97.61	0.4	pipe	232.61	231.70	229.07	228.64	229.26	228.94	3.35	2.76	2.36	0.18	1.62	3.01	0.30	0.30
Pipe-152	SDMH-1F	SDMH-1E	12	1.00	62.18	0.4	channel	231.70	231.61	228.44	228.17	228.94	228.91	2.76	2.70	2.35	0.52	1.25	2.99	0.74	0.74
Pipe-238	SDMH-14B	SDMH-14A	12	1.00	109.35	1.0	weir	237.75	236.71	231.86	230.77	231.97	231.77	5.78	4.94	3.56	0.10	1.85	4.53	0.00	1.00
Link687	THW-future	SDMH-1J	12	1.00	14.00	0.4	weir	235.00	234.82	231.32	231.26	231.96	231.51	3.04	3.31	2.33	1.22	2.95	2.97	0.00	0.68
Pipe-155	SDFS-1I	SDMH-1H	12	1.00	87.57	0.4	pipe	233.75	232.95	230.20	229.81	230.43	229.80	3.32	3.15	2.38	0.26	1.95	3.03	0.23	0.23
TractB	OutfallB	CulvertUP	24	2.00	120.00	3.2	pipe	230.00	229.00	225.80	222.00	226.08	224.55	3.92	4.45	693.57	20.18	1.92	13.87	2.55	1.00

Appendix D

BMP Sizing Tool Analysis



WES BMP Sizing Report

Project Information

Project Name	Frog Pond Oaks
Project Type	Subdivision
Location	Frog Pond lane
Stormwater Management Area	16228
Project Applicant	
Jurisdiction	CCSD1NCSA

Drainage Management Area

Name	Area (sq-ft)	Pre-Project Cover	Post-Project Cover	DMA Soil Type	BMP
O-F1 imp	6,605	Grass	ConventionalConcrete	D	O-F1 swale
O-F1 perv	1,508	Grass	LandscapeDsoil	D	O-F1 swale
O-F2 imp	9,373	Grass	ConventionalConcrete	D	O-F2 swale
O-F2 perv	1,705	Grass	LandscapeDsoil	D	O-F2 swale
O-W2 imp	7,700	Grass	Roofs	D	O-W2 Swale
O-W2 perv	1,856	Grass	LandscapeDsoil	D	O-W2 Swale
O-M2 imp	91,801	Grass	ConventionalConcrete	D	O-M2 RG SE
O-M2 perv	61,628	Grass	LandscapeDsoil	D	O-M2 RG SE
O-W1 imp	5,138	Grass	ConventionalConcrete	D	O-W1 Swale
O-W1 perv	1,697	Grass	LandscapeDsoil	D	O-W1 Swale
O-M1 C imp	55,513	Grass	Roofs	C	O-M1 RG SW
O-M1 C perv	48,139	Grass	LandscapeCsoil	C	O-M1 RG SW
O-M1 D imp	50,768	Grass	Roofs	D	O-M1 RG SW
O-M1 D perv	44,026	Grass	LandscapeDsoil	D	O-M1 RG SW
Forest	70,176	Forested	Forested	C	NA
O-S1 imp	1,147	Grass	ConventionalConcrete	D	O-S1 swale
O-S1 perv	620	Grass	LandscapeDsoil	D	O-S1 swale
O-S2 imp	2,734	Grass	ConventionalConcrete	D	O-S2 swale
O-S2 perv	629	Grass	LandscapeDsoil	D	O-S2 swale
O-S3 imp	4,173	Grass	ConventionalConcrete	D	O-S3 swale

			Concrete		
O-S3 perv	967	Grass	Landscape Soil	D	O-S3 swale

LID Facility Sizing Details

LID ID	Design Criteria	BMP Type	Facility Soil Type	Minimum Area (sq-ft)	Planned Areas (sq-ft)	Orifice Diameter (in)
O-M2 RG SE	Flow Control and Treatment	Rain Garden - Filtration	D1	5,397.6	5,400.0	4.0
O-M1 RG SW	Flow Control and Treatment	Rain Garden - Filtration	D1	7,242.6	7,265.0	4.2
O-W2 Swale	Flow Control and Treatment	Vegetated Swale - Filtration	D1	360.0	360.0	1.1
O-W1 Swale	Flow Control and Treatment	Vegetated Swale - Filtration	D1	253.0	352.0	0.9
O-F1 swale	Flow Control and Treatment	Vegetated Swale - Filtration	D1	306.4	352.0	1.0
O-F2 swale	Flow Control and Treatment	Vegetated Swale - Filtration	D1	422.7	424.0	1.2
O-S1 swale	Flow Control and Treatment	Vegetated Swale - Filtration	D1	63.2	103.0	0.5
O-S2 swale	Flow Control and Treatment	Vegetated Swale - Filtration	D1	127.0	128.0	0.6
O-S3 swale	Flow Control and Treatment	Vegetated Swale - Filtration	D1	194.0	240.0	0.8

Pond Sizing Details

1. FCWQT = Flow control and water quality treatment, WQT = Water quality treatment only
2. Depth is measured from the bottom of the facility and includes the three feet of media (drain rock, separation layer and growing media).
3. Maximum volume of the facility. Includes the volume occupied by the media at the bottom of the facility.
4. Maximum water storage volume of the facility. Includes water storage in the three feet of soil media assuming a 40 percent porosity.

Appendix E
Operations and Maintenance Plans



This Detail Drawing may not be altered or changed in any manner except by the City Engineer. It is the responsibility of the user to acquire the most current version.

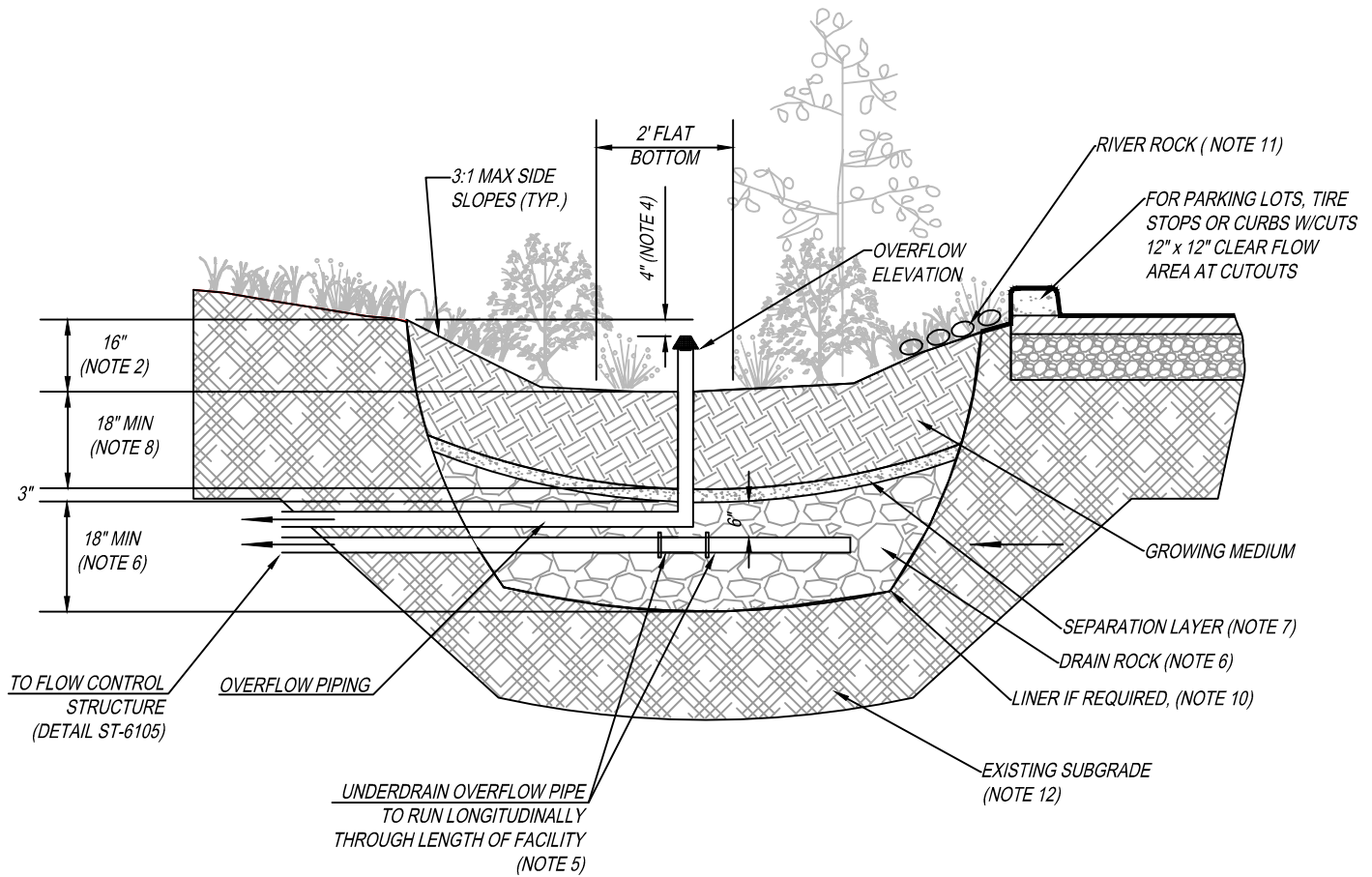

GENERAL NOTES:

1. **PROVIDE PROTECTION** FROM ALL VEHICLE TRAFFIC, EQUIPMENT STAGING, AND FOOT TRAFFIC IN PROPOSED INFILTRATION AREAS PRIOR TO, DURING AND AFTER CONSTRUCTION. UNLESS REQUIRED BY SITE CONDITIONS, UNLINED RAIN GARDENS ARE PREFERRED TO MAXIMIZE ONSITE INFILTRATION.
2. **DIMENSIONS:**
 - DEPTH OF BASIN (FROM TOP OF GROWING MEDIUM TO OVERFLOW ELEVATION); 12"
 - FLAT BOTTOM WIDTH: 2' MINIMUM
 - SIDE SLOPES OF RAIN GARDEN: 3:1 MAXIMUM
 - CENTERLINE SLOPE OF RAIN GARDEN: 0.5% OR LESS
3. **SETBACKS:**
 - FILTRATION RAIN GARDEN SHALL BE 10' FROM FOUNDATIONS AND 5' FROM PROPERTY LINES UNLESS APPROVED BY BUILDING OFFICIAL
4. **OVERFLOW:**
 - OVERFLOW REQUIRED. INLET ELEVATION SHALL ALLOW FOR 4" OF FREEBOARD, MINIMUM.
 - PROTECT FROM DEBRIS AND SEDIMENT WITH STRAINER OR GRATE.
5. **PIPING:**
 - PERFORATED UNDER-DRAIN PIPING: SHALL RUN LONGITUDINALLY THROUGH LENGTH OF FACILITY, SHALL BE ABS SCH. 40, CAST IRON, OR PVC SCH.40. MINIMUM DIAMETER IS 6". PIPING SHALL HAVE 1% GRADE AND FOLLOW THE UNIFORM PLUMBING CODE. PVC NOT ALLOWED ABOVE GROUND. WRAP UNDER-DRAIN IN FILTER FABRIC TO REDUCE TRANSPORT OF FINES. OVERFLOW PIPING: SHALL BE ABS SCH. 40, CAST IRON, OR PVC SCH. 40 AND SHALL NOT BE PERFORATED. MINIMUM DIAMETER IS 6". PIPING SHALL HAVE 1% GRADE AND FOLLOW THE UNIFORM PLUMBING CODE. PVC NOT ALLOWED ABOVE GROUND.
6. **DRAIN ROCK:**
 - SIZE: 1 1/2" to 3/4"-0 WASHED
 - DEPTH: 18" MINIMUM
7. **SEPARATION** BETWEEN DRAIN ROCK AND GROWING MEDIUM: SHALL BE A 3" LAYER OF 3/4" - 1/4" OPEN GRADED AGGREGATE.
8. **GROWING MEDIUM:**
 - DEPTH: 18" MINIMUM
 - SEE APPENDIX A FOR SPECIFICATION OR USE SAND/LOAM/COMPOST 3-WAY MIX.
 - FACILITY SURFACE AREA MAY BE REDUCED BY 25% WHEN GROWING MEDIA DEPTH IS INCREASED TO 30" OR MORE.
9. **VEGETATION:** FOLLOW LANDSCAPE PLANS OR REFER TO PLANTING REQUIREMENTS IN APPENDIX A.
10. **WATERPROOF LINER (IF REQUIRED):** SHALL BE 30 MIL PVC OR EQUIVALENT.
11. **INSTALL RIVER ROCK** SPLASH PAD OVER A NON WOVEN GEO TEXTILE FABRIC TO TRANSITION FROM INLETS TO GROWING MEDIUM. SIZE OF ROCK SHALL BE 1" - 3", 4 SQUARE FEET, 6" DEEP.
12. **SEASONAL HIGH GROUNDWATER SEPARATION:**
 - SEPARATION DISTANCE AS REQUIRED BY CITY.

Rain Garden - Filtration

DRAWING NUMBER: ST-6020

DRAWN BY: SR

SCALE: N.T.S.

FILE NAME: ST-6020.DWG

APPROVED BY: NK

DATE: 6/3/16

CITY OF
WILSONVILLE



PUBLIC WORKS STANDARDS

Rain Gardens Operations & Maintenance Plan

What to Look For	What to Do
Structural Components, including inlets and outlets/overflows, shall freely convey stormwater.	
Clogged inlets or outlets	-Remove sediment and debris from catch basins, trench drains and curb inlets and pipes to maintain at least 50% conveyance capacity at all times.
Cracked Drain Pipes	-Repair/seal cracks. Replace when repair is insufficient.
Check Dams	-Maintain 4 to 10 inch deep rock check dams at design intervals.
Vegetation	
Dead or strained vegetation	-Replant per original planting plan, or substitute from Appendix A. -Irrigate as needed. Mulch banks annually. DO NOT apply fertilizers, herbicides, or pesticides.
Tall Grass and Vegetation	-Cut back grass and prune overgrowth 1-2 times per year. Remove cuttings
Weeds	-Manually remove weeds. Remove all plant debris.
Growing/Filter Medium, including soil and gravels, shall sustain healthy plant cover and infiltrate within 72 hours.	
Gullies	-Fill, lightly compact, and plant vegetation to disperse flow.
Erosion	-Replace splash blocks or inlet gravel/rock.
Slope Slippage	-Stabilize 3:1 slopes/banks with plantings from Appendix A
Ponding	-Rake, till, or amend to restore infiltration rate.

Annual Maintenance Schedule:

Summer. Make any structural repairs. Improve filter medium as needed. Clear drain. Irrigate as needed.

Fall. Replant exposed soil and replace dead plants. Remove sediment and plant debris.

Winter. Monitor infiltration/flow-through rates. Clear inlets and outlets/overflows to maintain conveyance.

Spring. Remove sediment and plant debris. Replant exposed soil and replace dead plants. Mulch.

All seasons. Weed as necessary.

Maintenance Records: Record date, description, and contractor (if applicable) for all structural repairs, landscape maintenance, and facility cleanout activities. Keep work orders and invoices on file and make available upon request of the inspector.

Access: Maintain ingress/egress to design standards.

Infiltration/Flow Control: All facilities shall drain within 72 hours. Record time/date, weather, and site conditions when ponding occurs.

Pollution Prevention: All sites shall implement best management practices to prevent hazardous or solid wastes or excessive oil and sediment from contaminating stormwater. Contact _____ for immediate assistance responding to spills. Record time/date, weather, and site conditions if site activities contaminate stormwater.

Vectors (Mosquitoes & Rodents): Stormwater facilities shall not harbor mosquito larvae or rats that pose a threat to public health or that undermine the facility structure. Monitor standing water for small wiggling sticks perpendicular to the water's surface. Note holes/burrows in and around facilities. Call Clackamas County Vector Control for immediate assistance to eradicate vectors. Record time/date, weather, and site conditions when vector activity observed.

Rain Garden O & M Plan

DRAWING NUMBER: ST-6030

DRAWN BY: SR

SCALE: N.T.S.

FILE NAME: ST-6030.DWG

APPROVED BY: NK

DATE: 10/15/14

CITY OF
WILSONVILLE



PUBLIC WORKS STANDARDS

This Detail Drawing may not be altered or changed in any manner except by the City Engineer. It is the responsibility of the user to acquire the most current version.

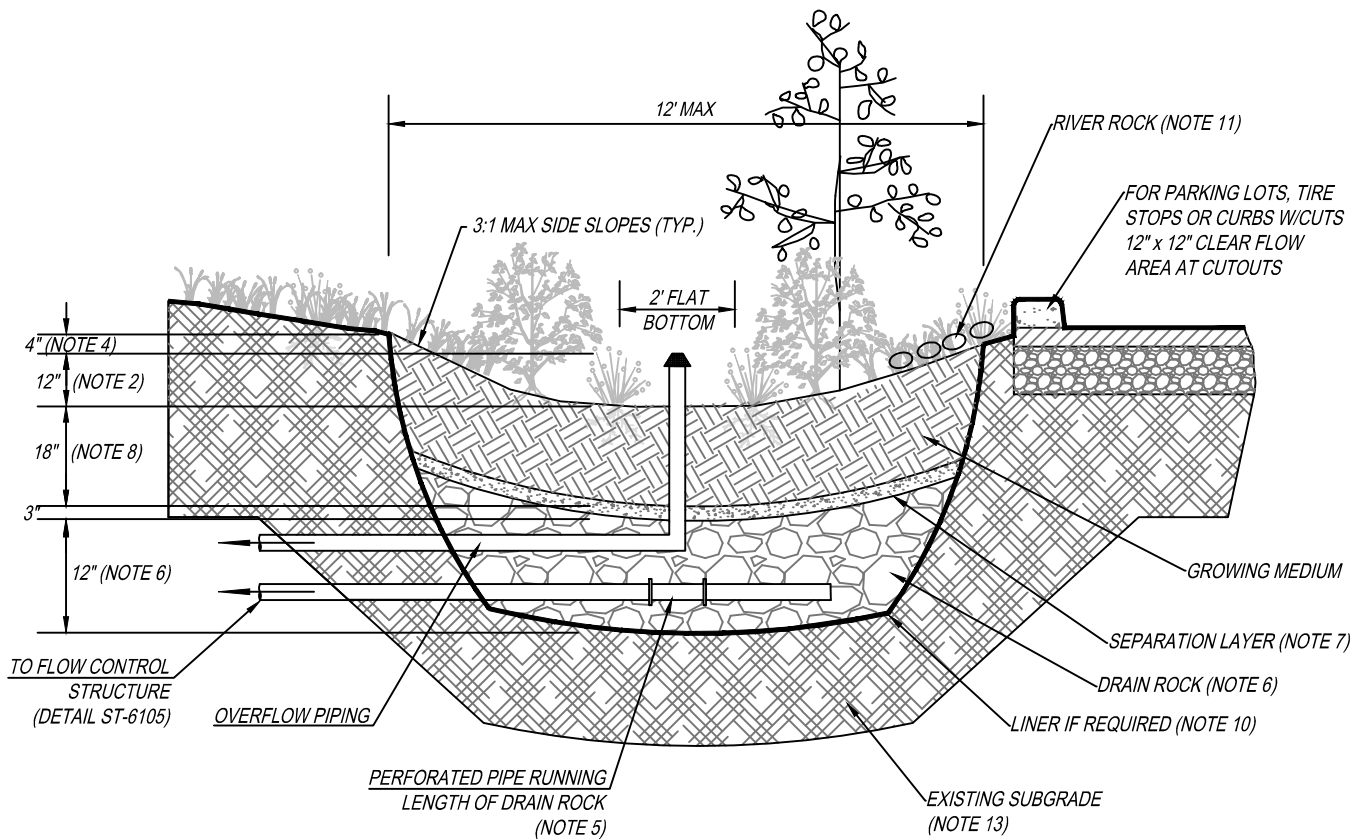

GENERAL NOTES:

1. **PROVIDE PROTECTION** FROM ALL VEHICLE TRAFFIC, EQUIPMENT STAGING, AND FOOT TRAFFIC IN PROPOSED INFILTRATION AREAS PRIOR TO, DURING AND AFTER CONSTRUCTION. UNLESS REQUIRED BY SITE CONDITIONS, UNLINED SWALES ARE PREFERRED TO ALLOW MAXIMUM INFILTRATION.
2. **DIMENSIONS:**
 - DEPTH OF SWALE (FROM TOP OF GROWING MEDIUM TO OVERFLOW ELEVATION); 12"
 - LONGITUDINAL SLOPE OF SWALE: 6.0% OR LESS
 - FLAT BOTTOM WIDTH: 2' MINIMUM
 - SIDE SLOPES OF SWALE: 3:1 MAXIMUM
3. **LOCATION/SETBACKS:**
 - FILTRATION SWALES SHALL BE 10' FROM FOUNDATIONS AND 5' FROM PROPERTY LINES UNLESS APPROVED BY BUILDING OFFICIAL
4. **OVERFLOW:**
 - INLET ELEVATION SHALL ALLOW FOR 4" OF FREEBOARD, MINIMUM.
 - PROTECT FROM DEBRIS AND SEDIMENT WITH STRAINER OR GRATE.
5. **PIPING:**
 - PERFORATED UNDER-DRAIN PIPING: SHALL BE ABS SCH. 40, CAST IRON, OR PVC SCH.40. MINIMUM DIAMETER IS 6". PIPING SHALL HAVE 1% GRADE AND FOLLOW THE UNIFORM PLUMBING CODE. PVC NOT ALLOWED ABOVE GROUND. WRAP UNDER-DRAIN IN FILTER FABRIC TO REDUCE TRANSPORT OF FINES.
 - OVERFLOW PIPING: SHALL BE ABS SCH. 40, CAST IRON, OR PVC SCH. 40 AND SHALL NOT BE PERFORATED. MINIMUM DIAMETER IS 6". PIPING SHALL HAVE 1% GRADE AND FOLLOW THE UNIFORM PLUMBING CODE. PVC NOT ALLOWED ABOVE GROUND.
6. **DRAIN ROCK:**
 - SIZE: 1 1/2" - 3/4" WASHED
 - DEPTH: 12"
7. **SEPARATION** BETWEEN DRAIN ROCK AND GROWING MEDIUM: SHALL BE A 3" LAYER OF 3/4" - 1/4" OPEN GRADED AGGREGATE.
8. **GROWING MEDIUM:**
 - 18" MINIMUM
 - SEE APPENDIX C FOR SPECIFICATION OR USE SAND/LOAM/COMPOST 3-WAY MIX.
 - FACILITY SURFACE AREA MAY BE REDUCED BY 25% WHEN GROWING MEDIA DEPTH IS INCREASED TO 30" OR MORE.
9. **VEGETATION:** FOLLOW LANDSCAPE PLANS OR REFER TO PLANTING REQUIREMENTS IN APPENDIX A.
10. **WATERPROOF LINER (IF REQUIRED):** SHALL BE 30 MIL PVC OR EQUIVALENT.
11. **INSTALL RIVER ROCK** SPLASH PAD OVER A NON WOVEN GEO TEXTILE FABRIC TO TRANSITION FROM INLETS TO GROWING MEDIUM. SIZE OF ROCK SHALL BE 1" TO 3", 4 SQUARE FEET, 6" DEEP.
12. **CHECK DAMS:** SHALL BE PLACED ACCORDING TO FACILITY DESIGN. REFER TO DETAIL ST-6100 FOR PROFILE AND SPACING.
13. **SEASONAL HIGH GROUNDWATER SEPARATION:**
 - SEPARATION DISTANCE AS REQUIRED BY CITY.

Vegetated Swale - Filtration

DRAWING NUMBER: ST-6045

DRAWN BY: SR

SCALE: N.T.S.

FILE NAME: ST-6045.DWG

APPROVED BY: NK

DATE: 6/3/16

CITY OF
WILSONVILLE



PUBLIC WORKS STANDARDS

Vegetated Swales Operations & Maintenance Plan

What to Look For	What to Do
Structural Components, including inlets and outlets/overflows, shall freely convey stormwater.	
Clogged inlets or outlets	-Remove sediment and debris from catch basins, trench drains, curb inlets and pipes to maintain at least 50% conveyance capacity at all times.
Cracked Drain Pipes	-Replace/seal cracks. Replace when repair is insufficient.
Check Dams	-Maintain 4 - 10 inch deep rock check dams at design intervals.
Vegetation	
Dead or strained vegetation	-Replant per original planting plan, or substitute from Appendix A. -Irrigate as needed. Mulch banks annually. DO NOT apply fertilizers, herbicides, or pesticides.
Tall Grass and Vegetation	-Cut back to 4-6 inches, 1-2 times per year. Remove cuttings
Weeds	-Manually remove weeds. Remove all plant debris.
Growing/Filter Medium, including soil and gravels, shall sustain healthy plant cover and infiltrate within 72 hours.	
Gullies	-Fill, lightly compact, and plant vegetation to disperse flow.
Erosion	-Restore or create outfalls, checkdams, or splash blocks where necessary.
Slope Sippage	-Stabilize Slope.
Ponding	-Rake, till, or amend to restore infiltration rate.

Annual Maintenance Schedule:

Summer. Make any structural repairs. Improve filter medium as needed. Clear drain. Irrigate as needed.

Fall. Replant exposed soil and replace dead plants. Remove sediment and plant debris.

Winter. Monitor infiltration/flow-through rates. Clear inlets and outlets/overflows to maintain conveyance.

Spring. Remove sediment and plant debris. Replant exposed soil and replace dead plants. Mulch.

All seasons. Weed as necessary.

Maintenance Records: Record date, description, and contractor (if applicable) for all structural repairs, landscape maintenance, and facility cleanout activities. Keep work orders and invoices on file and make available upon request of the inspector.

Access: Maintain ingress/egress to design standards.

Infiltration/Flow Control: All facilities shall drain within 72 hours. Record time/date, weather, and site conditions when ponding occurs.

Pollution Prevention: All sites shall implement best management practices to prevent hazardous or solid wastes or excessive oil and sediment from contaminating stormwater. Contact _____ for immediate assistance responding to spills. Record time/date, weather, and site conditions if site activities contaminate stormwater.

Vectors (Mosquitoes & Rodents): Stormwater facilities shall not harbor mosquito larvae or rats that pose a threat to public health or that undermine the facility structure. Monitor standing water for small wiggling sticks perpendicular to the water's surface.

Note holes/burrows in and around facilities. Call Clackamas County Vector Control for immediate assistance to eradicate vectors. Record time/date, weather, and site conditions when vector activity observed.

Vegetated Swale O & M Plan

DRAWING NUMBER: ST-6055

DRAWN BY: SR

SCALE: N.T.S.

FILE NAME: ST-6055.DWG

APPROVED BY: NK

DATE: 10/8/14

CITY OF
WILSONVILLE



PUBLIC WORKS STANDARDS

STORMWATER FACILITIES OPERATIONS AND MAINTENANCE CHECKLIST

Problem	Frequency	Trigger	Preferred Condition
<i>Sediment Accumulation in Treatment Area</i>	<i>Monthly from November through April Annually Required</i>	<i>Sediment depth exceeds 3 inches</i>	<i>Sediment removed from vegetated treatment area: level side to side and drains freely toward outlet; no standing water within 24 hours of any major storm (1" in 24 hours)</i>
<i>Erosion Scouring</i>	<i>Monthly from November through April Annually Required</i>	<i>Monthly from November through April Annually Required</i>	<i>Repair ruts or bare areas by filling with topsoil during dry season; regrade and replant large bare areas.</i>
<i>Standing Water</i>	<i>Monthly from November through April and after any major storm (1 inch in 24 hours)</i>	<i>Standing water in the planter between storms that does not drain freely</i>	<i>Remove sediment or trash blockages; improve end to end grade so there is no standing water 24 hours after any major storm (1 inch in 24 hours)</i>
<i>Flow not Distributed Evenly</i>	<i>Monthly from November through April Annually Required</i>	<i>Flows unevenly distributed through planter width due to uneven or clogged flow spreader</i>	<i>Level the spreader and clean so that flows spread evenly over entire planter width</i>
<i>Settlement/ Misalignment</i>	<i>Annually Required</i>	<i>Failure of planters has created safety, function, or design problem</i>	<i>Planter replaced or repaired to design standards</i>
<i>Constant Baseflow</i>	<i>Monthly from November through April Annually Required</i>	<i>Small, continual flow of water through the planter even after weeks without rain; planter bottom has an eroded, muddy channel</i>	<i>Add a low-flow pea gravel drain the length of the planter or bypass the baseflow around the planter</i>
<i>Vegetation</i>	<i>Monthly from November through April Annually Required</i>	<i>Vegetation blocking more than 10% of the inlet pipe opening</i>	<i>No vegetation blocking the inlet pipe opening</i>
<i>Poor Vegetation Coverage</i>	<i>Monthly Annually Required</i>	<i>Grass or other vegetation is sparse, or bare in more than 10% of the planter area</i>	<i>Determine cause of poor growth and correct the condition; replant with plants (per Appendix A) as needed to meet facility standards</i>
<i>Invasive Vegetation</i>	<i>Monthly Annually Required</i>	<i>No invasive vegetation is planted or permitted to remain</i>	<i>no invasive vegetation present; remove excessive weeds. Control if complete eradication is not feasible</i>
<i>Rodents</i>	<i>Monthly Annually Required</i>	<i>Evidence of rodents or rodent damage</i>	<i>No rodents; functioning facility</i>
<i>Insects</i>	<i>Annually Required</i>	<i>Insects such as wasps and hornets that interfere with maintenance activities</i>	<i>Harmful Insects removed</i>
<i>Trash and Debris</i>	<i>Monthly and after any major storm (1 inch in 24 hours) Annually Required</i>	<i>Visual evidence of trash, debris or dumping</i>	<i>Trash and Debris removed from facility</i>
<i>Contamination and Pollution</i>	<i>Monthly from November through April Annually Required</i>	<i>Any evidence of oil, gasoline, contamination or other pollutants</i>	<i>No contaminants or pollutants present; coordinate removal/cleanup with local water quality response agency</i>
<i>Obstructed Inlet/Outlet</i>	<i>Monthly and after any major storm event (1 inch in 24 hours) Annually Required</i>	<i>Inlet/outlet areas clogged with sediment, vegetation or debris</i>	<i>Clear inlet and outlet; obstructions removed</i>
<i>Excessive Shading</i>	<i>Monthly from November through April Annually Required</i>	<i>Vegetation growth is poor because unlight does not reach planter</i>	<i>Trim over-hanging limbs and/or remove brushy vegetation as needed</i>
<i>Vegetation</i>	<i>Monthly from November through April Annually Required</i>	<i>Specified or approved grass grows so tall that it competes with shrubs and/or becomes a fire danger</i>	<i>String trim non-wetland grasses to 4 inch to 6 inch and remove clippings; protect woody vegetation</i>

Stormwater Facilities Operations & Maintenance Checklist

DRAWING NUMBER: ST-6115

DRAWN BY: SR

SCALE: N.T.S.

FILE NAME: ST-6115.DWG

APPROVED BY: NK

DATE: 10/3/14

CITY OF
WILSONVILLE



PUBLIC WORKS STANDARDS

This Detail Drawing may not be altered or changed in any manner except by the City Engineer. It is the responsibility of the user to acquire the most current version.

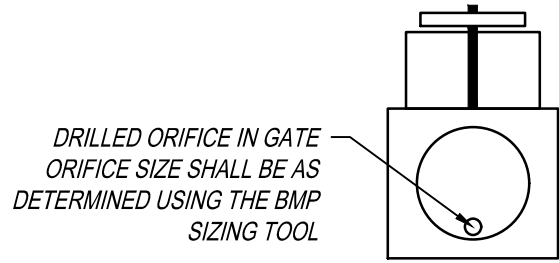

**END VIEW
(PVC GATE VALVE)**

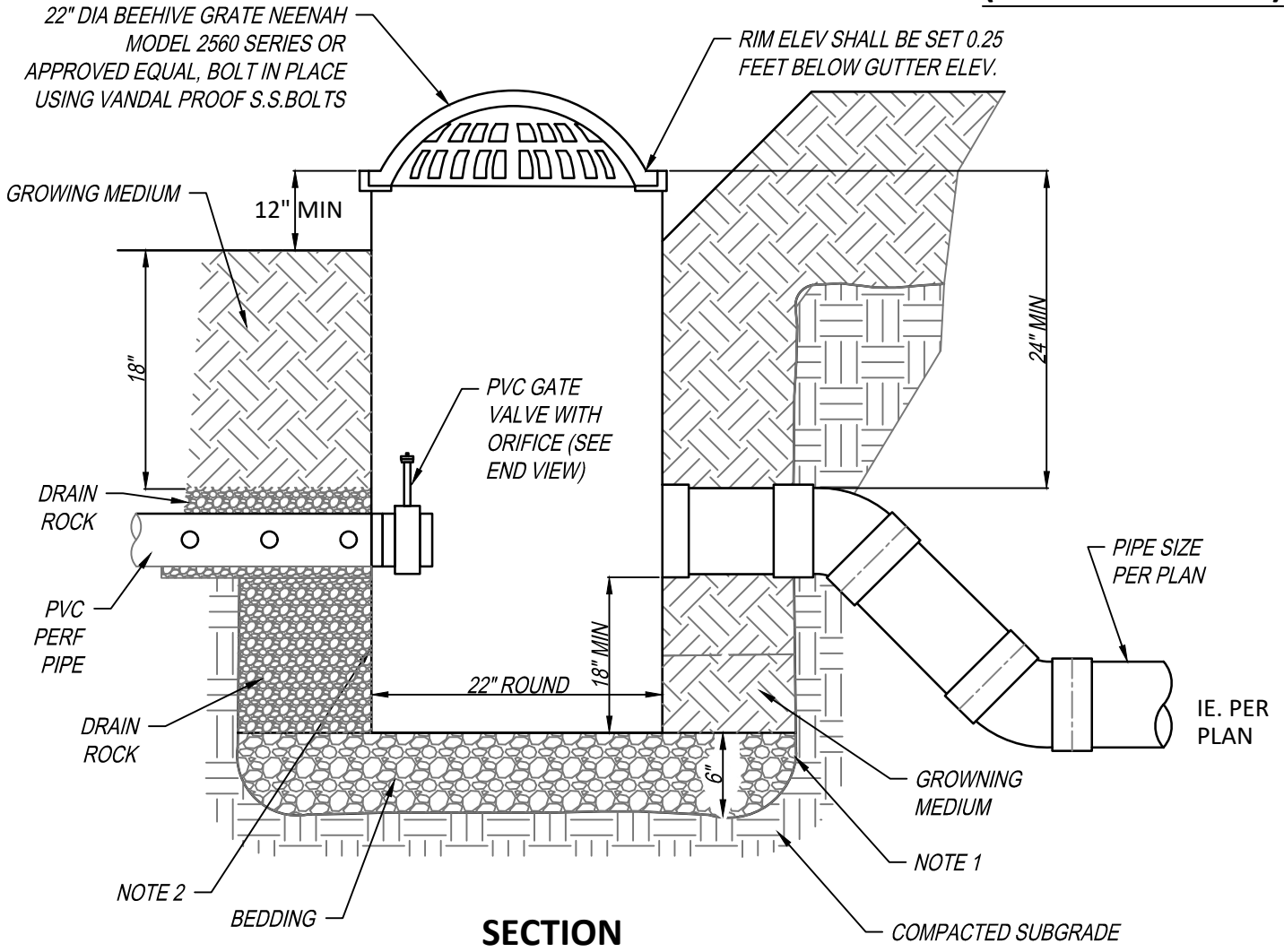

SECTION

NOTES:

1. CONTRACTOR TO WIDEN EXCAVATION AS REQUIRED TO OBTAIN COMPACTION WITH CONTRACTORS COMPACTION EQUIPMENT.
2. 10 GA. STEEL PLATE, BITUMINOUS COATED BASIN AS MANUFACTURED BY GIBSON STEEL, GRATEMASTER OR APPROVED EQUAL.
3. BEDDING SHALL BE 6" OF COMPACTED 3/4"-0 CRUSHED ROCK BASE MATERIAL.

Beehive Overflow Inlet			CITY OF WILSONVILLE PUBLIC WORKS STANDARDS
DRAWING NUMBER: ST-6120	DRAWN BY: SR	SCALE: N.T.S.	
FILE NAME: ST-6120.dwg	APPROVED BY: NK	DATE: 2/15/18	



Appendix C

Transportation Impact Memorandum dated
November 2022, by DKS and Associates





WILSONVILLE FROG POND WEST OAKS SUBDIVISION TRANSPORTATION IMPACT ANALYSIS

NOVEMBER 2021

PREPARED FOR CITY OF WILSONVILLE



PREPARED BY DKS ASSOCIATES

Scott Mansur, P.E., PTOE
Jenna Bogert, P.E.
Travis Larson, E.I.



117 COMMERCIAL STREET NE, SUITE 310, SALEM, OR 97301 • 503.391.8773 • DKSASSOCIATES.COM

TABLE OF CONTENTS

INTRODUCTION	4
EXISTING CONDITIONS	6
STUDY AREA ROADWAY NETWORK.....	6
EXISTING TRAFFIC VOLUMES.....	8
INTERSECTION PERFORMANCE MEASURES.....	8
EXISTING INTERSECTION OPERATIONS.....	10
PROJECT IMPACTS	11
PROPOSED DEVELOPMENT.....	11
FUTURE ANALYSIS SCENARIOS.....	11
TRIP GENERATION.....	11
VEHICLE TRIP DISTRIBUTION.....	12
FUTURE TRAFFIC VOLUMES.....	12
FUTURE INTERSECTION OPERATIONS.....	15
SITE REVIEW	16
SUMMARY OF PROJECT IMPACTS	17
APPENDIX	18
A. TRAFFIC COUNT DATA.....	A
B. HCM REPORTS – EXISTING.....	B
C. STAGE II LIST.....	C
D. HCM REPORTS – EXISTING + PROJECT.....	D
E. HCM REPORTS – EXISTING + STAGE II.....	E
F. HCM REPORTS – EXISTING + PROJECT + STAGE II.....	F
G. SITE PLAN.....	G

LIST OF FIGURES

FIGURE 1: STUDY AREA	5
FIGURE 2: 2021 EXISTING PM TRAFFIC VOLUMES	9
FIGURE 3: PROJECT TRIPS AND DISTRIBUTION	13
FIGURE 4: 2021 FUTURE PM TRAFFIC VOLUMES.....	14

LIST OF TABLES

TABLE 1: STUDY AREA AND PROPOSED PROJECT CHARACTERISTICS	4
TABLE 2: STUDY AREA ROADWAY CHARACTERISTICS	6
TABLE 3: EXISTING PM INTERSECTION OPERATIONS	10
TABLE 4: VEHICLE TRIP GENERATION	12
TABLE 5: EXISTING PM, PROJECT, AND STAGE II INTERSECTION OPERATIONS.....	15

INTRODUCTION

This study evaluates the transportation impacts associated with the proposed Frog Pond West Oaks Subdivision development to be located on Frog Pond Lane in Wilsonville, Oregon. The owner desires to construct 41 single-family homes consistent with the Frog Pond West Master Plan.¹

The purpose of this transportation impact analysis is to identify potential mitigation measures needed to offset transportation impacts that the proposed development may have on the nearby transportation network. The impact analysis is focused on the study intersections, which were selected for evaluation in coordination with City staff. The intersections are listed below and shown on Figure 1.

- Stafford Road/ Frog Pond Lane
- Stafford Road/ Brisband Street
- Boeckman Road/ Stafford Road/ Advance Road/ Wilsonville Road
- Boeckman Road/ Willow Creek Drive
- Boeckman Road/ Canyon Creek Road
- Boeckman Road/ Parkway Avenue

Table 1 lists important characteristics of the study area and proposed project.

TABLE 1: STUDY AREA AND PROPOSED PROJECT CHARACTERISTICS

STUDY AREA	
NUMBER OF STUDY INTERSECTIONS	Six
ANALYSIS PERIODS	Weekday PM peak hour (highest hour between 4pm – 6pm)
PROPOSED DEVELOPMENT	
SIZE AND LAND USE	10.3-acre plot with 41 residential house lots
NET PROJECT TRIPS	42 total PM peak hour trips (26 in, 16 out)
VEHICLE ACCESS POINTS	Access to the site will be provided via Frog Pond Lane, Brisband Street, and Willow Creek Drive.

¹ Frog Pond West Master Plan, City of Wilsonville, July 17, 2017.



FIGURE 1: STUDY AREA

EXISTING CONDITIONS

This chapter provides documentation of existing study area conditions, including the study area roadway network, pedestrian and bicycle facilities, and existing traffic volumes and operations.

STUDY AREA ROADWAY NETWORK

Key roadways and their existing characteristics in the study area are summarized in Table 2. The functional classifications for the streets are provided in the City of Wilsonville Transportation System Plan (TSP)² and the Frog Pond Master Plan.

TABLE 2: STUDY AREA ROADWAY CHARACTERISTICS

ROADWAY	FUNCTIONAL CLASSIFICATION	ROADWAY OWNERSHIP	POSTED SPEED	SIDEWALKS	BIKE FACILITIES	ON-STREET PARKING
FROG POND LANE	Collector/Local ^a	Split City/County ^b	N/A	No	No	No
BRISBAND STREET	Local	City of Wilsonville	N/A	Partial ^c	No	Yes
WILLOW CREEK DRIVE	Collector	City of Wilsonville	N/A	Yes	Partial ^d	Partial ^d
STAFFORD ROAD	Major Arterial	Split City/County ^e	45 mph	No	No	No
BOECKMAN ROAD	Minor Arterial	City of Wilsonville	35 mph	Partial ^f	Partial ^f	No
WILSONVILLE ROAD	Minor Arterial	City of Wilsonville	35 mph	Yes	Yes	No
ADVANCE ROAD	Collector	Split City/County ^g	35 mph ^h	Partial ⁱ	Partial ⁱ	No
CANYON CREEK ROAD	Minor Arterial	City of Wilsonville	35 mph	Yes	Yes	No
PARKWAY AVENUE	Minor Arterial	City of Wilsonville	40 mph	Yes	Partial ^j	No

^a Frog Pond Lane is a Collector east of Willow Creek Drive and a Local west of Willow Creek Drive.

^b City jurisdiction from Stafford Road to ±1333 ft west; county jurisdiction from that point to western terminus.

^c New intermittent sidewalk exists; plans show it fully connected once construction is finished.

^d Bike lanes exist south of Brisband Street; on-street parking exists north of Brisband Street.

^e City jurisdiction south of Frog Pond Lane; county jurisdiction north of Frog Pond Lane.

^f Sidewalk primarily exists on south side of street. Bicycle lanes are intermittent.

^g City jurisdiction west of 60th Avenue; county jurisdiction east of 60th Avenue.

^h Speed limit increases to 45 mph outside of the city.

ⁱ Sidewalk and bike lane present on the south side between Stafford Road and 63rd Avenue.

^j Intermittent bike lanes.

² Wilsonville Transportation System Plan, Amended November 16, 2020.

NEARBY BICYCLE AND PEDESTRIAN FACILITIES

The Frog Pond West neighborhood is continually developing and constructing new pedestrian and bicycle infrastructure. Willow Creek Drive, a collector road partially constructed within the Frog Pond West area, will have sidewalks and bicycle lanes on both sides of the street. Frog Pond Lane, currently under-developed, will also have sidewalks for the full length of the street and bicycle lanes just east of Willow Creek Drive on both sides of the street. Along Boeckman Road and Advance Road, sidewalks exist on the south side and there are intermittent bicycle lanes. Stafford Road has no bicycle or pedestrian facilities. Wilsonville Road has bicycle lanes and sidewalks on both sides of the street.

NEARBY PUBLIC TRANSIT SERVICE

South Metro Area Regional Transit (SMART) provides public transportation services within Wilsonville and the outlying areas. There are no bus stops currently adjacent to the Frog Pond West neighborhood, but Route 4 covers Advance Road and Wilsonville Road with the closest stop to the project site approximately 0.15 mile south of the Wilsonville Road/ Advance Road intersection at Landover Road. After the completion of the Boeckman Dip Improvement project (UU-01), transit service is expected to be expanded to the Frog Pond West area.

PLANNED PROJECTS

The City of Wilsonville Transportation System Plan (TSP) has a list of Higher Priority projects which includes the recommended projects reasonably expected to be funded through 2035. These are the highest priority solutions to meet the City's most important needs. The list includes the following projects that impact the key roadways near the proposed project site.³

- RE-12A - Frog Pond West Neighborhood Collector Roads: Construction of collector roadways within the Frog Pond West neighborhood per the Master Plan.
- RW-01 - Boeckman Road Bridge and Corridor Improvements: Improvements along Boeckman Road near I-5 as well as improvement of the Parkway Avenue intersection.
- UU-01 - Boeckman Road Dip Improvements: Installation of bridge along Boeckman Road at the vertical curve and a new traffic signal at the Boeckman Road/ Canyon Creek Road intersection.
- UU-06 - Stafford Road Urban Upgrade: Upgrade of Stafford Road from Kahle Road to Boeckman Road to applicable roadway cross-section standards.
- SI-03 - Stafford Road/65th Avenue Intersection Improvements: New signal or roundabout in conjunction with 65th/Elligsen intersection to facilitate improved safety and operations.
- BW-04 - Boeckman Road Bike Lanes and Sidewalk Infill: Improvements to pedestrian and bicycle facilities between Parkway Avenue and Canyon Creek Road.

³ Table 5-3/Figure 5-4, Wilsonville Transportation System Plan, Amended November 16, 2020.

EXISTING TRAFFIC VOLUMES

New turning movement count data was collected on Thursday, September 30th, 2021, during the weekday PM peak period (4:00-6:00 pm) at all study intersections. These new counts were then evaluated for any necessary factoring to represent typical existing PM peak volumes.

In July 2021, ODOT released their final COVID Monitoring Traffic Report, which indicated that statewide traffic levels were approximately back to “pre-COVID” levels (plus or minus 5%). Other local agencies in the area (including City of Wilsonville) have anecdotally noted similar observations on the local street system. Due to this fact, and that the traffic counts were collected when West Linn-Wilsonville schools were back to full-time, in-person attendance, no COVID adjustment factor was applied to the traffic counts.

Figure 2 shows the 2021 Existing PM peak hour traffic volumes for the study intersections, along with the lane configurations and traffic control.

INTERSECTION PERFORMANCE MEASURES

Agency mobility standards often require intersections to meet level of service (LOS) or volume-to-capacity (v/c) intersection operation thresholds.

- The intersection LOS is similar to a “report card” rating based upon average vehicle delay. Level of service A, B, and C indicate conditions where traffic moves without significant delays over periods of peak hour travel demand. Level of service D and E are progressively worse operating conditions. Level of service F represents conditions where average vehicle delay has become excessive and demand has exceeded capacity. This condition is typically evident in long queues and delays.
- The volume-to-capacity (v/c) ratio represents the level of saturation of the intersection or individual movement. It is determined by dividing the peak hour traffic volume by the maximum hourly capacity of an intersection or turn movement. When the V/C ratio approaches 0.95, operations become unstable and small disruptions can cause the traffic flow to break down, resulting in the formation of excessive queues.

The City of Wilsonville requires study intersections on public streets to meet its minimum acceptable level of service (LOS) standard of LOS D for the overall intersection for the PM peak period.⁴

⁴ Policy 5, Wilsonville Transportation System Plan 2013, Amended November 16, 2020.

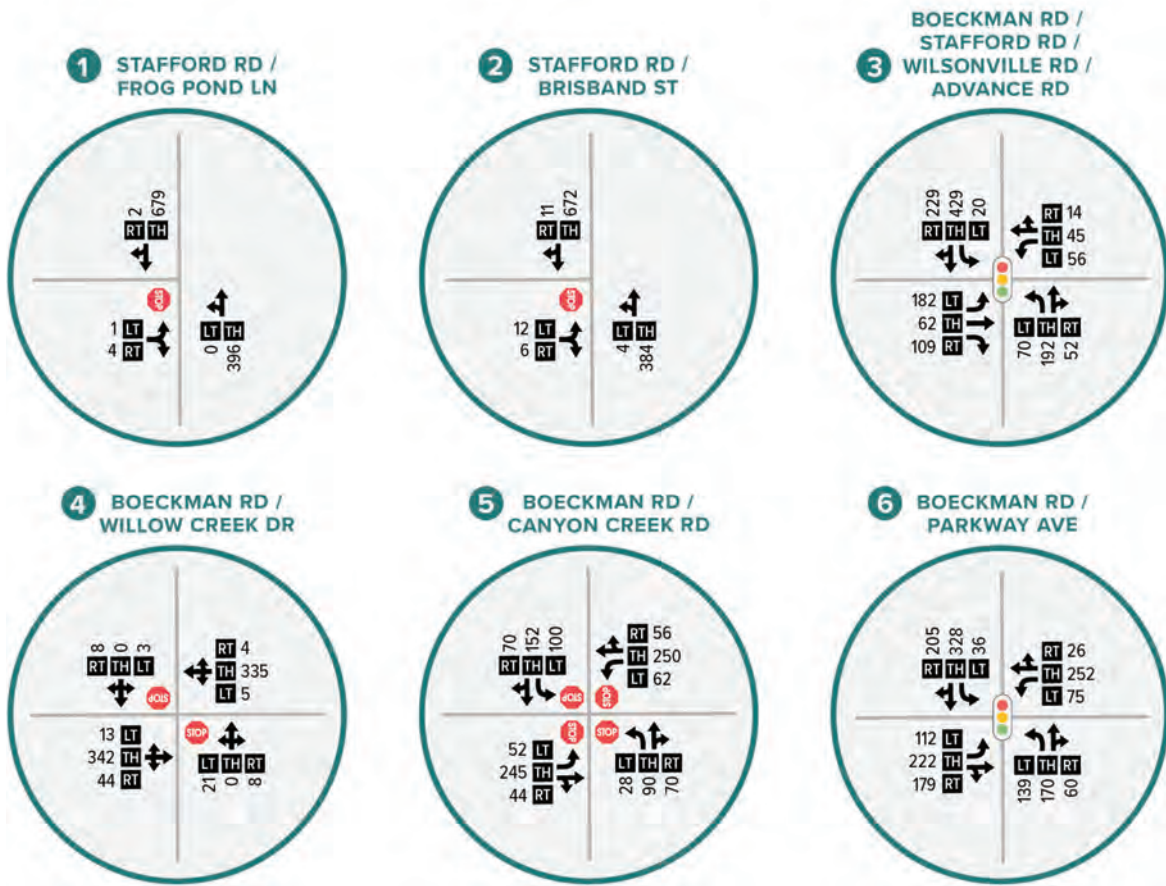
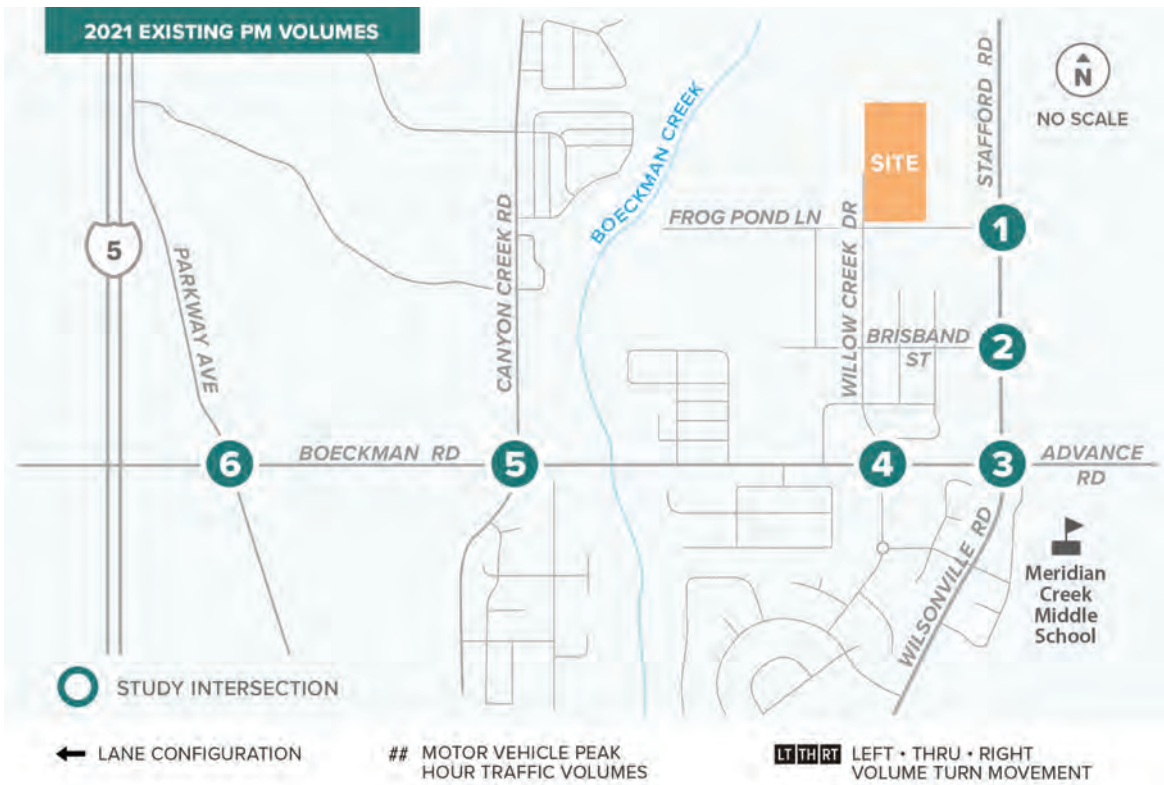

FIGURE 2: 2021 EXISTING PM TRAFFIC VOLUMES

EXISTING INTERSECTION OPERATIONS

An analysis of the 2021 existing intersection operations was performed at the study intersections to determine the current operating conditions of the study area. Intersection operations were analyzed for the PM peak hour using Highway Capacity Manual (HCM) 6th Edition methodology.⁵ The volume to capacity (v/c) ratio, delay, and level of service (LOS) of each study intersection are listed in Table 3.

TABLE 3: EXISTING PM INTERSECTION OPERATIONS

INTERSECTION	OPERATING STANDARD	PM PEAK HOUR		
		V/C	DELAY	LOS
SIGNALIZED CONTROL				
BOECKMAN RD-ADVANCE RD/ STAFFORD RD-WILSONVILLE RD	LOS D	0.66	19.1	B
BOECKMAN RD/ PARKWAY AVE	LOS D	0.80	23.2	C
ALL-WAY STOP CONTROLLED				
BOECKMAN RD/ CANYON CREEK RD	LOS D	0.69	19.4	C
TWO-WAY STOP CONTROLLED				
STAFFORD RD/ FROG POND LN	LOS D	0.02	15.4	A/C
STAFFORD RD/ BRISBAND ST	LOS D	0.08	20.2	A/C
BOECKMAN RD/ WILLOW CREEK DR	LOS D	0.10	17.1	A/C
SIGNALIZED INTERSECTION: Delay = Average Intersection Delay (secs) v/c = Total Volume-to-Capacity Ratio LOS = Total Level of Service	ALL-WAY STOP CONTROLLED INTERSECTION: Delay = Average Intersection Delay (secs) v/c = Critical Movement Volume-to-Capacity Ratio LOS = Total Level of Service	TWO-WAY STOP CONTROLLED INTERSECTION: Delay = Critical Movement Delay (secs) v/c = Critical Movement Volume-to-Capacity Ratio LOS = Critical Levels of Service (Major/Minor Road)		

Bold/Highlighted = Does not meet the operating standard/mobility target

As shown, all study intersections meet the City of Wilsonville’s operating standards for the existing conditions.

⁵ Highway Capacity Manual, 6th Edition, Transportation Research Board, 2017.

PROJECT IMPACTS

This chapter reviews the impacts that the proposed development may have on the study area transportation system. This analysis includes site plan evaluation, trip generation, trip distribution, and future year traffic volumes and operating conditions for the study intersections.

PROPOSED DEVELOPMENT

The proposed development includes 41 single-family home lots. The location of the proposed development is shown on all analysis figures and is part of the Frog Pond West Master Plan.⁶ The parcel is currently used primarily for agricultural purposes with one single-family home on it.

FUTURE ANALYSIS SCENARIOS

Operating conditions were analyzed at the study intersections for the following traffic scenarios. The comparison of the following scenarios enables the assessment of project impacts:

- Existing + Project
- Existing + Stage II
- Existing + Project + Stage II

All future analysis scenarios assume the same traffic control as existing conditions. Stage II represents traffic from other developments that have Stage II approval or are under construction in Wilsonville. For this analysis, the Frog Pond Estates, Vista, and Crossing developments were also included in the Stage II list.

TRIP GENERATION

Trip generation is the method used to estimate the number of vehicles added to site driveways and the adjacent roadway network by a development during a specified period (e.g., the PM peak hour). For this study, the Institute of Transportation Engineers (ITE) trip generation rates for Single-Family Detached Housing (210) were used to estimate the site's trip generation, which is based on the number of lots in the development.⁷ As one home will be removed from the site during construction, the trips from that home have been subtracted from the total trips.

The trip generation for the proposed development is shown in Table 4. As shown, the proposed development is expected to generate a net total 42 PM peak hour trips (26 in, 16 out). The project trips at the study intersections are shown on Figure 3.

⁶ Frog Pond West Master Plan, City of Wilsonville, July 17, 2017.

⁷ Trip Generation Manual, 11th Edition, Institute of Transportation Engineers, 2021.

TABLE 4: VEHICLE TRIP GENERATION

LAND USE	ITE DESCRIPTION (CODE)	UNITS	PM PEAK TRIP RATE ^A	PM PEAK TRIPS			WEEKDAY
				IN	OUT	TOTAL	
NEW HOMES	SINGLE-FAMILY DETACHED HOUSING (210)	41 Lots	1.05 trips per lot	27	16	43	444
EXISTING HOME REMOVED	SINGLE-FAMILY DETACHED HOUSING (210)	1 Lot	1.00 trips per lot	-1	-0	-1	-15
Total Net New Trips				26	16	42	429

^A = PM peak trip rate is back-calculated from the fitted curve equation

VEHICLE TRIP DISTRIBUTION

Vehicle trip distribution provides an estimation of where vehicles would be coming from and going to. It is given as a percentage at key gateways to the study area and is used to route project trips through the study intersections. Figure 3 shows the trip distribution for the proposed site. The trip distribution was based on the Wilsonville Travel Demand Model, existing traffic volumes, and previous Frog Pond traffic analyses.⁸

PROJECT TRIPS THROUGH CITY OF WILSONVILLE INTERCHANGE AREAS

The project trips through the two City of Wilsonville I-5 interchange areas were estimated based on the trip generation and distribution assumptions. Approximately 5% of the project trips are expected to travel through the I-5/Wilsonville Road interchange area and 5% are expected to travel through the I-5/Elligsen Road interchange area; that is, the proposed development is expected to generate 2 net new PM peak hour trips through the I-5/Wilsonville Road interchange area and 2 net new PM peak hour trips through the I-5/Elligsen Road interchange area.

FUTURE TRAFFIC VOLUMES

Traffic volumes were estimated at the study intersections for the three future analysis scenarios. The future scenarios include various combinations of three types of traffic: Existing, Project, and Stage II. Stage II development trips are included based on the list of currently approved Stage II developments provided by City staff.⁹ These Stage II trips also included the vehicle trip generation from the Frog Pond Crossing, Frog Pond Vista, and Frog Pond Estates subdivisions. A list of all these Stage II developments is included in the appendix. Figure 4 shows the PM peak hour traffic volumes for the following scenarios: Existing + Project, Existing + Stage II, Existing + Project + Stage II.

⁸ Wilsonville Frog Pond West Vista Subdivision, Transportation Impact Analysis, DKS Associates, August 2021.

⁹ Email from Daniel Pauly, City of Wilsonville, September 9, 2021

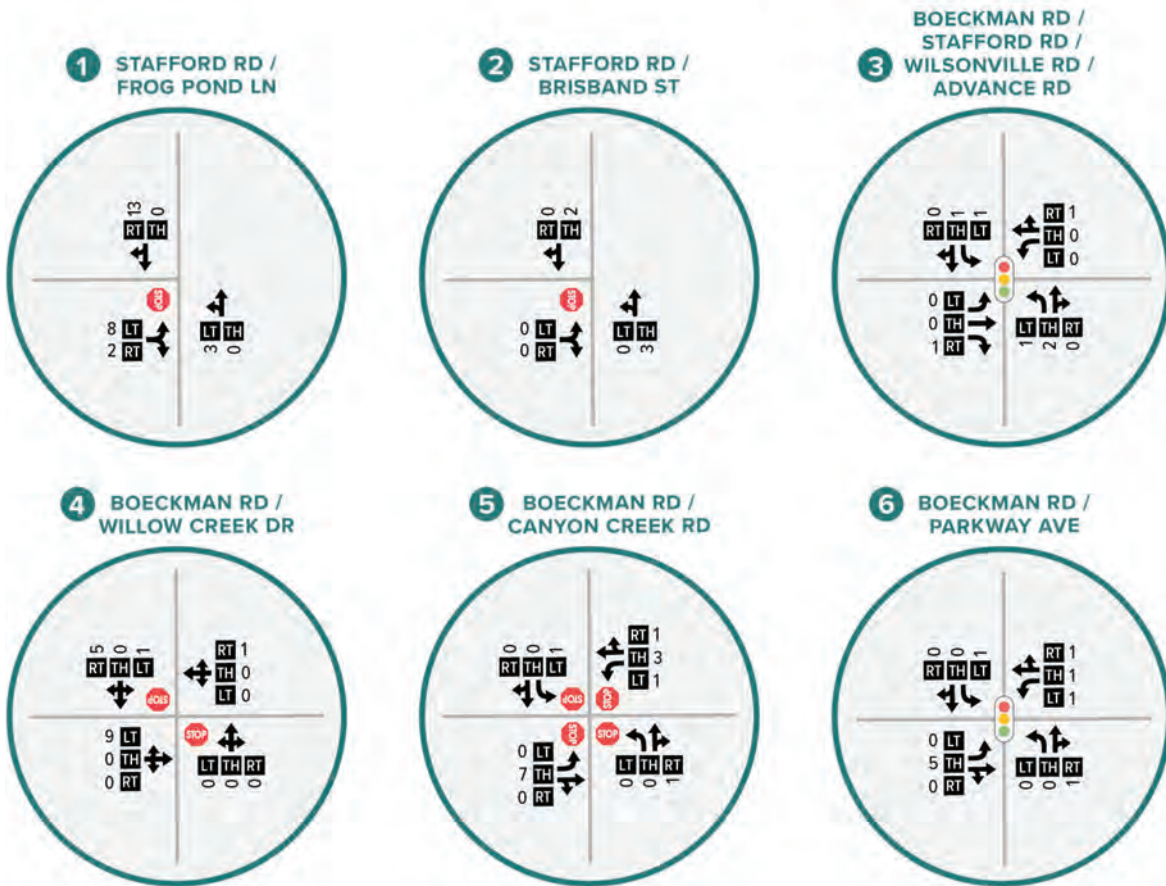
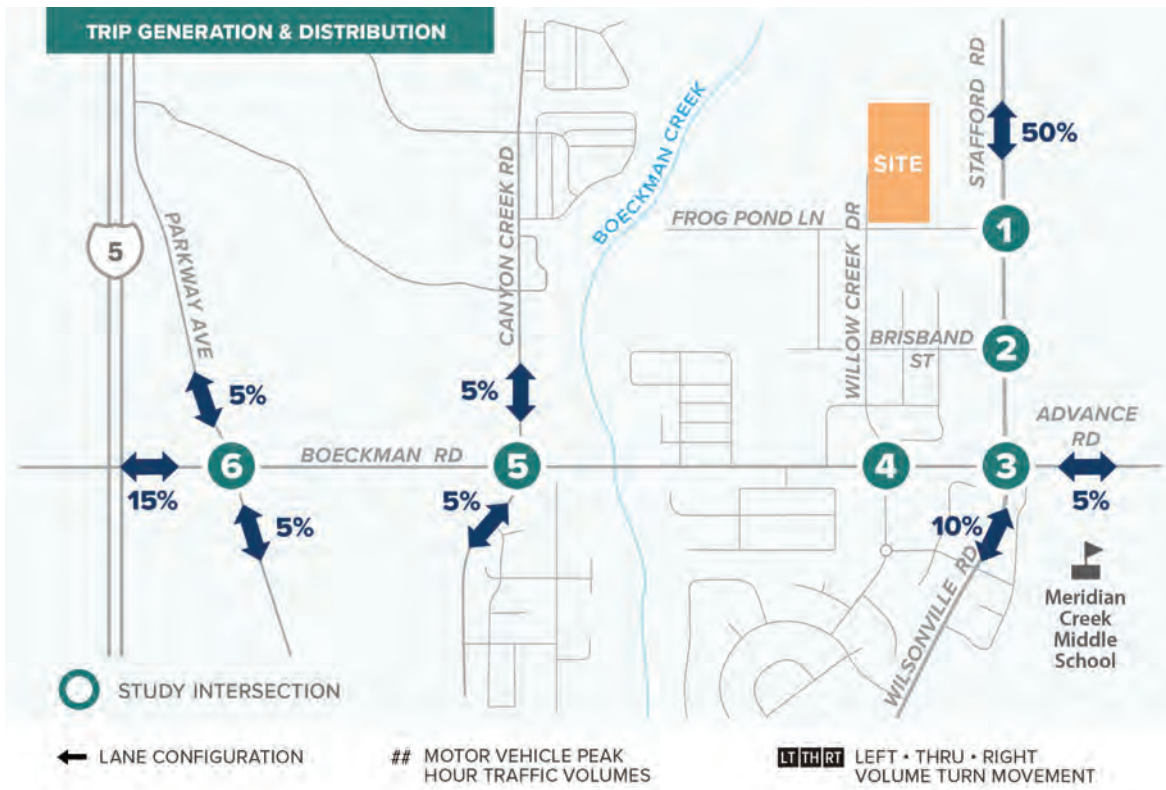

FIGURE 3: PROJECT TRIPS AND DISTRIBUTION

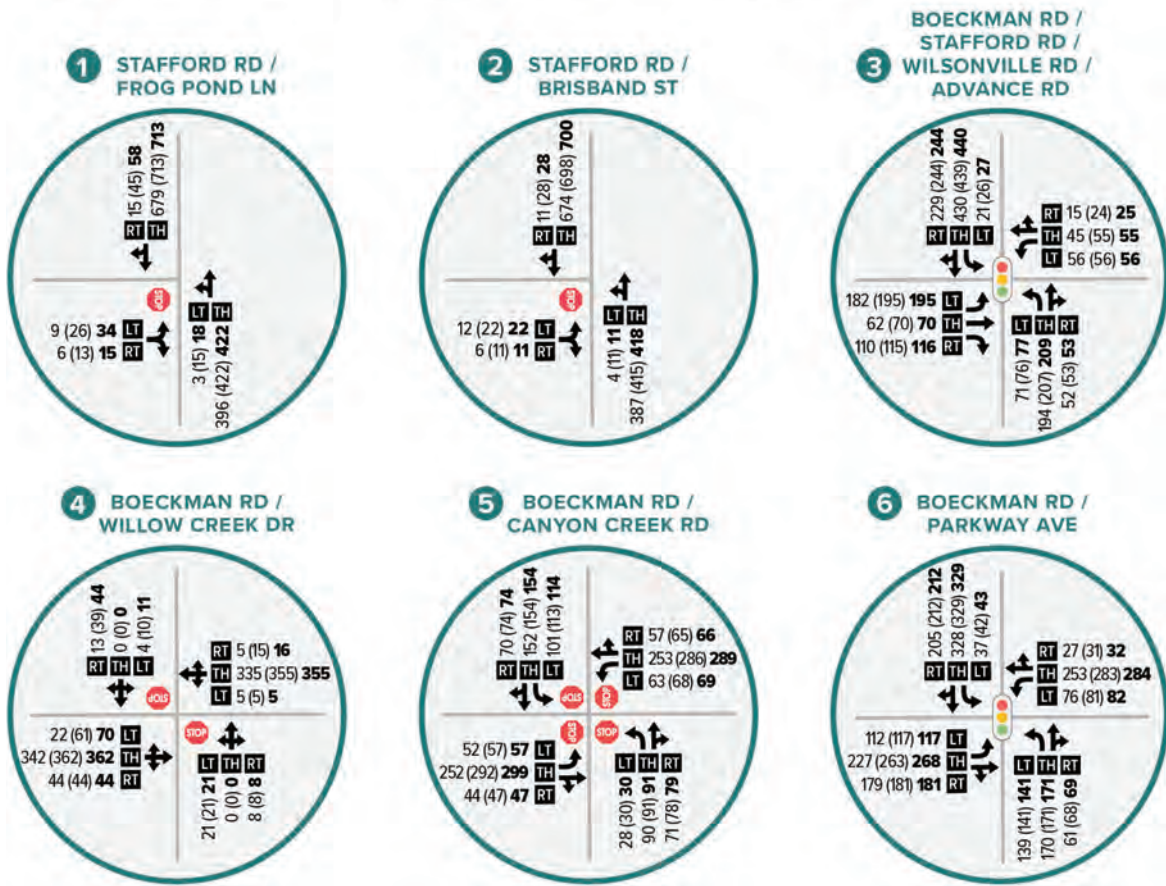
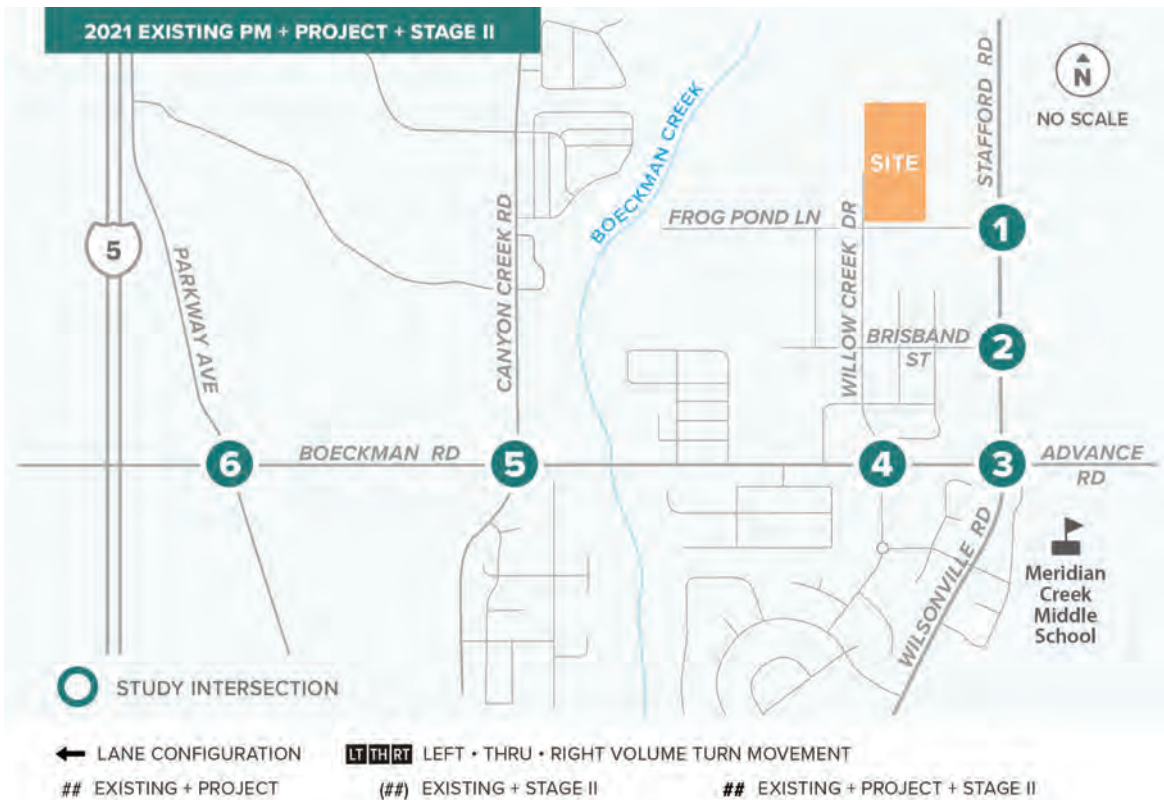

FIGURE 4: 2021 FUTURE PM TRAFFIC VOLUMES

FUTURE INTERSECTION OPERATIONS

Intersection operations were analyzed for the PM peak hour at all study intersections for the three future scenarios using Highway Capacity Manual (HCM) 6th Edition methodology.¹⁰ The volume to capacity (v/c) ratio, delay, and level of service (LOS) of each study intersection are listed in Table 5.

As shown, all study intersections meet the City of Wilsonville’s operating standard for the future conditions.

TABLE 5: EXISTING PM, PROJECT, AND STAGE II INTERSECTION OPERATIONS

INTERSECTION	OPERATING STANDARD	EXISTING PM + PROJECT			EXISTING PM + STAGE II			EXISTING PM + PROJECT + STAGE II		
		V/C	DELAY	LOS	V/C	DELAY	LOS	V/C	DELAY	LOS
SIGNALIZED CONTROL										
BOECKMAN RD-ADVANCE RD/ STAFFORD RD-WILSONVILLE RD	LOS D	0.66	19.2	B	0.70	20.3	C	0.70	20.4	C
BOECKMAN RD/ PARKWAY AVE	LOS D	0.81	23.4	C	0.85	26.7	C	0.85	27.0	C
ALL-WAY STOP CONTROLLED										
BOECKMAN RD/ CANYON CREEK RD	LOS D	0.70	20.0	C	0.84	28.6	C	0.85	30.2	D
TWO-WAY STOP CONTROLLED										
STAFFORD RD/ FROG POND LN	LOS D	0.06	19.7	A/C	0.20	25.8	A/D	0.26	28.5	A/D
STAFFORD RD/ BRISBAND ST	LOS D	0.08	20.3	A/C	0.16	23.8	A/C	0.16	23.9	A/C
BOECKMAN RD/ WILLOW CREEK DR	LOS D	0.10	17.7	A/C	0.14	22.8	A/C	0.15	24.0	A/C

SIGNALIZED INTERSECTION:
 Delay = Average Intersection Delay (secs)
 v/c = Total Volume-to-Capacity Ratio
 LOS = Total Level of Service

ALL-WAY STOP CONTROLLED INTERSECTION:
 Delay = Average Intersection Delay (secs)
 v/c = Critical Movement Volume-to-Capacity Ratio
 LOS = Total Level of Service

TWO-WAY STOP CONTROLLED INTERSECTION:
 Delay = Critical Movement Delay (secs)
 v/c = Critical Movement Volume-to-Capacity Ratio
 LOS = Critical Levels of Service (Major/Minor Road)

Bold/Highlighted = Does not meet the operating standard/mobility target

¹⁰ Highway Capacity Manual, 6th Edition, Transportation Research Board, 2017.

SITE REVIEW

This chapter reviews the provided site plan to determine consistency with the Frog Pond West Master Plan, including street configuration and zoning, and alignment with the Wilsonville Development Code or Construction Standards, including vehicular access, parking, circulation, and street standards. The site plan is included in the appendix.

FROG POND WEST MASTER PLAN CONSISTENCY

Figure 16 in the Frog Pond West Master Plan¹¹ shows two north-south connecting streets between Willow Creek Drive and Yarrow Lane. The project site plan (and adjacent property's site plan to the west) show the two street connections have been replaced by one pedestrian-only connection. It is desired to provide an additional motor vehicle north-south street connection between Willow Creek Road and Yarrow Lane. Further coordination between the developer and City of Wilsonville staff is recommended to determine the desired local street network.

The residential zoning and land use in the site plan appears to be consistent with the Master Plan.¹²

ACCESS SPACING

The proposed project is required to comply with access spacing requirements as laid out in the City Transportation System Plan.¹³ The access points for the new development is consistent with the Frog Pond Master Plan and meets the City's minimum spacing standards for Collectors. There are no spacing requirements for local streets.

SITE CIRCULATION

The proposed project provides adequate site circulation when considering the entirety of the Frog Pond West Master Plan. The proposed site will have access to Stafford Road via Frog Pond Lane and access to Boeckman Road via Willow Creek Drive.

STREETS

The Frog Pond West Master Plan provides the street type plan and required cross sections for all streets in the Frog Pond West development.¹⁴ The developer will be responsible for building the internal local streets with on-street parking and sidewalks. No dedicated bicycle facilities are required. The developer will also be required to build half street improvements along the property frontage that meet the Frog Pond West Master Plan cross section standard. Willow Creek Drive is to be an Internal Collector with two travel lanes (with bike sharrows), on street parking, planter

¹¹ Figure 16, Frog Pond West Master Plan, City of Wilsonville, July 17, 2017.

¹² Figure 6 & Table 1, Frog Pond West Master Plan, City of Wilsonville, July 17, 2017.

¹³ Table 3-2, Wilsonville Transportation System Plan, Amended November 2020.

¹⁴ Figure 19, Frog Pond West Master Plan, City of Wilsonville, July 17, 2017.

strips, and sidewalks. Frog Pond Lane is to be a Gateway Collector with sidewalks on both sides, planter strips, buffered bike lanes, two travel lanes, and a median.

SIGHT DISTANCE

Adequate sight distance should be provided at the proposed alleys and internal streets. Objects (e.g., fences, walls, or vegetation) located near the intersections may inhibit sight distance for drivers attempting to turn out of a minor street onto the major street. Prior to occupancy, sight distance at any proposed access point will need to be verified, documented, and stamped by a registered professional Civil or Traffic Engineer licensed in the State of Oregon to assure that buildings, signs, or landscaping does not restrict sight distance.

SUMMARY OF PROJECT IMPACTS

The key findings of the transportation impact study for the Frog Pond West Oaks development are discussed below.

- The project will consist of 41 single-family home lots as part of the Frog Pond West Master Plan. The parcel is currently used for agricultural purposes with one single-family home on it.
- The proposed development is expected to generate a net total of 42 PM peak hour trips (26 in, 16 out).
- Of the net project trips, approximately two (5%) trips are expected to travel through the I-5/Wilsonville Road interchange area and two (5%) trips is expected to travel through the I-5/Elligsen Road interchange area.
- All study intersections are anticipated to meet City of Wilsonville operating standards under all future analysis scenarios.
- Further coordination between the developer and City of Wilsonville staff is recommended to determine the desired local street network, specifically consideration for an additional north-south vehicle street connection between Will Creek Road and Yarrow Lane.
- The developer will be responsible for building the internal local streets both within and fronting the property with on-street parking and sidewalks.
- The developer will also be required to build half street improvements along Frog Pond Lane and Willow Creek Drive along the property frontage that meet the Frog Pond West Master Plan cross section standard.
- Prior to occupancy, sight distance at any proposed access point will need to be verified, documented, and stamped by a registered professional Civil or Traffic Engineer licensed in the State of Oregon to assure that buildings, signs, or landscaping does not restrict sight distance.

APPENDIX

CONTENTS

A. TRAFFIC COUNT DATA

B. HCM REPORTS – EXISTING

C. STAGE II LIST

D. HCM REPORTS – EXISTING + PROJECT

E. HCM REPORTS – EXISTING + STAGE II

F. HCM REPORTS – EXISTING + STAGE II + PROJECT

G. SITE PLAN

A. TRAFFIC COUNT DATA



(303) 216-2439
www.alltrafficdata.net

Location: 6 SW Stafford Rd & SW Frog Pond Ln PM

Date: Thursday, September 30, 2021

Peak Hour: 04:45 PM - 05:45 PM

Peak 15-Minutes: 05:20 PM - 05:35 PM

Peak Hour

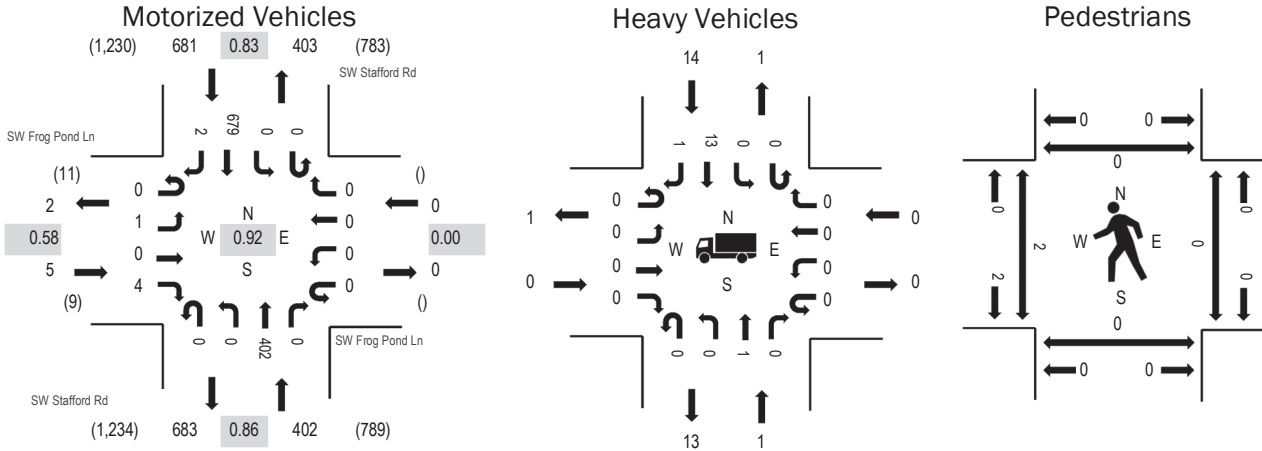

Note: Total study counts contained in parentheses.

	HV%	PHF
EB	0.0%	0.58
WB	0.0%	0.00
NB	0.2%	0.86
SB	2.1%	0.83
All	1.4%	0.92

Traffic Counts - Motorized Vehicles

Interval Start Time	SW Frog Pond Ln Eastbound				SW Frog Pond Ln Westbound				SW Stafford Rd Northbound				SW Stafford Rd Southbound				Total	Rolling Hour
	U-Turn	Left	Thru	Right	U-Turn	Left	Thru	Right	U-Turn	Left	Thru	Right	U-Turn	Left	Thru	Right		
4:00 PM	0	0	0	1	0	0	0	0	0	1	38	0	0	0	47	0	87	971
4:05 PM	0	0	0	0	0	0	0	0	0	0	39	0	0	0	31	0	70	965
4:10 PM	0	0	0	0	0	0	0	0	0	1	33	0	0	0	48	0	82	983
4:15 PM	0	0	0	0	0	0	0	0	0	1	28	0	0	0	41	0	70	988
4:20 PM	0	0	0	0	0	0	0	0	0	1	39	0	0	0	52	0	92	1,004
4:25 PM	0	0	0	1	0	0	0	0	0	0	36	0	0	0	43	0	80	1,011
4:30 PM	0	0	0	1	0	0	0	0	0	2	19	0	0	0	44	1	67	1,036
4:35 PM	0	0	0	0	0	0	0	0	0	0	36	0	0	0	47	1	84	1,060
4:40 PM	0	0	0	0	0	0	0	0	0	0	33	0	0	0	44	0	77	1,064
4:45 PM	0	0	0	0	0	0	0	0	0	0	29	0	0	0	59	0	88	1,088
4:50 PM	0	0	0	2	0	0	0	0	0	0	34	0	0	0	57	0	93	1,084
4:55 PM	0	0	0	1	0	0	0	0	0	0	31	0	0	0	49	0	81	1,066
5:00 PM	0	0	0	0	0	0	0	0	0	0	38	0	0	0	43	0	81	1,057
5:05 PM	0	0	0	1	0	0	0	0	0	0	36	0	0	0	50	1	88	
5:10 PM	0	0	0	0	0	0	0	0	0	0	46	0	0	0	41	0	87	
5:15 PM	0	0	0	0	0	0	0	0	0	0	32	0	0	0	53	1	86	
5:20 PM	0	1	0	0	0	0	0	0	0	0	28	0	0	0	70	0	99	
5:25 PM	0	0	0	0	0	0	0	0	0	0	29	0	0	0	76	0	105	
5:30 PM	0	0	0	0	0	0	0	0	0	0	31	0	0	0	60	0	91	
5:35 PM	0	0	0	0	0	0	0	0	0	0	32	0	0	0	56	0	88	
5:40 PM	0	0	0	0	0	0	0	0	0	0	36	0	0	0	65	0	101	
5:45 PM	0	0	0	0	0	0	0	0	0	1	33	0	0	0	50	0	84	
5:50 PM	0	0	0	1	0	0	0	0	0	0	24	0	0	0	50	0	75	
5:55 PM	0	0	0	0	0	0	0	0	0	0	22	0	0	0	50	0	72	
Count Total	0	1	0	8	0	0	0	0	0	7	782	0	0	0	1,226	4	2,028	
Peak Hour	0	1	0	4	0	0	0	0	0	0	402	0	0	0	679	2	1,088	

Traffic Counts - Heavy Vehicles, Bicycles on Road, and Pedestrians/Bicycles on Crosswalk

Interval Start Time	Heavy Vehicles					Interval Start Time	Bicycles on Roadway					Interval Start Time	Pedestrians/Bicycles on Crosswalk				
	EB	NB	WB	SB	Total		EB	NB	WB	SB	Total		EB	NB	WB	SB	Total
4:00 PM	0	2	0	1	3	4:00 PM	0	0	0	0	0	4:00 PM	0	0	0	0	0
4:05 PM	0	0	0	1	1	4:05 PM	0	0	0	0	0	4:05 PM	0	0	0	0	0
4:10 PM	0	2	0	1	3	4:10 PM	0	0	0	0	0	4:10 PM	0	0	0	0	0
4:15 PM	0	2	0	1	3	4:15 PM	0	0	0	0	0	4:15 PM	0	0	0	0	0
4:20 PM	0	2	0	2	4	4:20 PM	0	0	0	0	0	4:20 PM	0	0	0	0	0
4:25 PM	1	0	0	0	1	4:25 PM	0	0	0	0	0	4:25 PM	0	0	0	0	0
4:30 PM	1	0	0	1	2	4:30 PM	0	0	0	0	0	4:30 PM	0	0	0	0	0
4:35 PM	0	0	0	0	0	4:35 PM	0	0	0	0	0	4:35 PM	0	0	0	0	0
4:40 PM	0	0	0	1	1	4:40 PM	0	0	0	0	0	4:40 PM	0	0	0	0	0
4:45 PM	0	0	0	2	2	4:45 PM	0	0	0	0	0	4:45 PM	0	0	0	0	0
4:50 PM	0	0	0	1	1	4:50 PM	0	0	0	0	0	4:50 PM	0	0	0	0	0
4:55 PM	0	0	0	1	1	4:55 PM	0	0	0	0	0	4:55 PM	0	0	0	0	0
5:00 PM	0	0	0	0	0	5:00 PM	0	0	0	0	0	5:00 PM	0	0	0	0	0
5:05 PM	0	0	0	2	2	5:05 PM	0	0	0	0	0	5:05 PM	0	0	0	0	0
5:10 PM	0	1	0	2	3	5:10 PM	0	0	0	0	0	5:10 PM	0	0	0	0	0
5:15 PM	0	0	0	1	1	5:15 PM	0	0	0	0	0	5:15 PM	0	0	0	0	0
5:20 PM	0	0	0	1	1	5:20 PM	0	0	0	0	0	5:20 PM	0	0	0	0	0
5:25 PM	0	0	0	0	0	5:25 PM	0	0	0	0	0	5:25 PM	0	0	0	0	0
5:30 PM	0	0	0	2	2	5:30 PM	0	0	0	0	0	5:30 PM	0	0	0	0	0
5:35 PM	0	0	0	1	1	5:35 PM	0	0	0	0	0	5:35 PM	0	0	0	0	0
5:40 PM	0	0	0	1	1	5:40 PM	0	0	0	0	0	5:40 PM	2	0	0	0	2
5:45 PM	0	0	0	0	0	5:45 PM	0	0	0	0	0	5:45 PM	2	0	0	0	2
5:50 PM	0	0	0	0	0	5:50 PM	0	0	0	0	0	5:50 PM	0	0	0	0	0
5:55 PM	0	0	0	0	0	5:55 PM	0	0	0	0	0	5:55 PM	0	0	0	0	0
Count Total	2	9	0	22	33	Count Total	0	0	0	0	0	Count Total	4	0	0	0	4
Peak Hour	0	1	0	14	15	Peak Hour	0	0	0	0	0	Peak Hour	2	0	0	0	2



(303) 216-2439
www.alltrafficdata.net

Location: 5 SW Stafford Rd & SW Brisbane St PM

Date: Thursday, September 30, 2021

Peak Hour: 04:45 PM - 05:45 PM

Peak 15-Minutes: 05:20 PM - 05:35 PM

Peak Hour

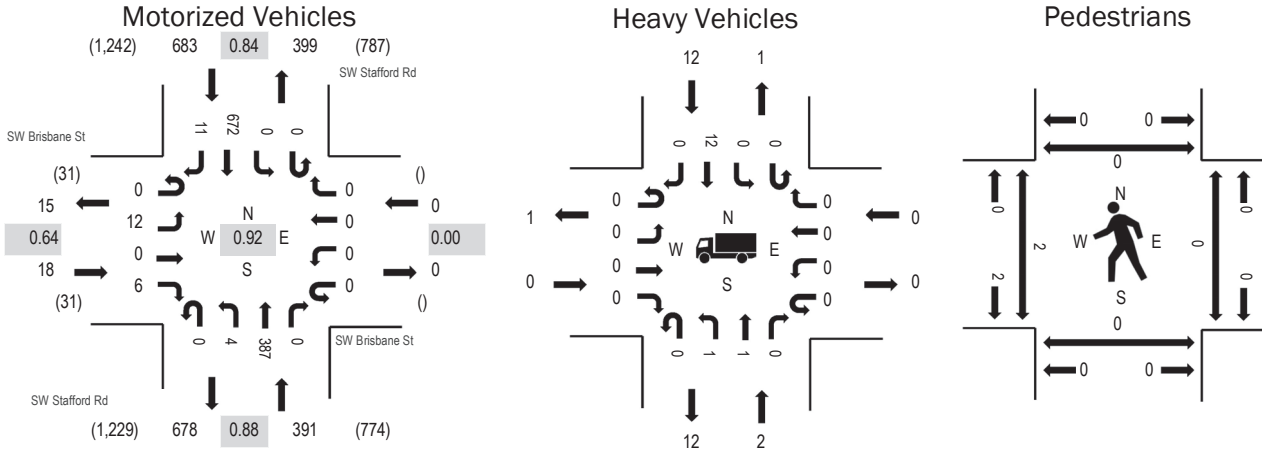

Note: Total study counts contained in parentheses.

	HV%	PHF
EB	0.0%	0.64
WB	0.0%	0.00
NB	0.5%	0.88
SB	1.8%	0.84
All	1.3%	0.92

Traffic Counts - Motorized Vehicles

Interval Start Time	SW Brisbane St Eastbound				SW Brisbane St Westbound				SW Stafford Rd Northbound				SW Stafford Rd Southbound				Total	Rolling Hour
	U-Turn	Left	Thru	Right	U-Turn	Left	Thru	Right	U-Turn	Left	Thru	Right	U-Turn	Left	Thru	Right		
4:00 PM	0	0	0	0	0	0	0	0	0	0	37	0	0	0	49	0	86	986
4:05 PM	0	1	0	0	0	0	0	0	0	0	41	0	0	0	33	0	75	981
4:10 PM	0	1	0	0	0	0	0	0	0	1	34	0	0	0	46	0	82	992
4:15 PM	0	0	0	1	0	0	0	0	0	0	30	0	0	0	42	0	73	998
4:20 PM	0	2	0	0	0	0	0	0	0	0	38	0	0	0	48	2	90	1,010
4:25 PM	0	1	0	0	0	0	0	0	0	0	35	0	0	0	44	0	80	1,017
4:30 PM	0	1	0	2	0	0	0	0	0	1	21	0	0	0	48	2	75	1,042
4:35 PM	0	1	0	1	0	0	0	0	0	0	34	0	0	0	44	0	80	1,062
4:40 PM	0	1	0	0	0	0	0	0	0	1	29	0	0	0	43	3	77	1,068
4:45 PM	0	0	0	1	0	0	0	0	0	0	30	0	0	0	60	0	91	1,092
4:50 PM	0	1	0	0	0	0	0	0	0	0	33	0	0	0	55	0	89	1,089
4:55 PM	0	1	0	1	0	0	0	0	0	0	31	0	0	0	53	2	88	1,077
5:00 PM	0	2	0	0	0	0	0	0	0	0	35	0	0	0	41	3	81	1,061
5:05 PM	0	3	0	1	0	0	0	0	0	0	34	0	0	0	48	0	86	
5:10 PM	0	1	0	2	0	0	0	0	0	0	43	0	0	0	42	0	88	
5:15 PM	0	0	0	0	0	0	0	0	0	0	28	0	0	0	55	2	85	
5:20 PM	0	1	0	0	0	0	0	0	0	0	27	0	0	0	66	3	97	
5:25 PM	0	0	0	1	0	0	0	0	0	1	29	0	0	0	74	0	105	
5:30 PM	0	0	0	0	0	0	0	0	0	2	32	0	0	0	61	0	95	
5:35 PM	0	0	0	0	0	0	0	0	0	0	32	0	0	0	54	0	86	
5:40 PM	0	3	0	0	0	0	0	0	0	1	33	0	0	0	63	1	101	
5:45 PM	0	0	0	0	0	0	0	0	0	0	35	0	0	0	52	1	88	
5:50 PM	0	1	0	0	0	0	0	0	0	0	23	0	0	0	51	2	77	
5:55 PM	0	0	0	0	0	0	0	0	0	1	22	0	0	0	47	2	72	
Count Total	0	21	0	10	0	0	0	0	0	8	766	0	0	0	1,219	23	2,047	
Peak Hour	0	12	0	6	0	0	0	0	0	4	387	0	0	0	672	11	1,092	

Traffic Counts - Heavy Vehicles, Bicycles on Road, and Pedestrians/Bicycles on Crosswalk

Interval Start Time	Heavy Vehicles					Interval Start Time	Bicycles on Roadway					Interval Start Time	Pedestrians/Bicycles on Crosswalk				
	EB	NB	WB	SB	Total		EB	NB	WB	SB	Total		EB	NB	WB	SB	Total
4:00 PM	0	2	0	1	3	4:00 PM	0	0	0	0	0	4:00 PM	0	0	0	0	0
4:05 PM	0	0	0	0	0	4:05 PM	0	0	0	0	0	4:05 PM	0	0	0	0	0
4:10 PM	0	2	0	1	3	4:10 PM	0	0	0	0	0	4:10 PM	0	0	0	0	0
4:15 PM	0	2	0	0	2	4:15 PM	0	0	0	0	0	4:15 PM	0	0	0	0	0
4:20 PM	0	2	0	1	3	4:20 PM	0	0	0	0	0	4:20 PM	0	0	0	0	0
4:25 PM	0	0	0	2	2	4:25 PM	0	0	0	0	0	4:25 PM	0	0	0	0	0
4:30 PM	0	0	0	2	2	4:30 PM	0	0	0	0	0	4:30 PM	0	0	0	0	0
4:35 PM	0	0	0	0	0	4:35 PM	0	0	0	0	0	4:35 PM	0	0	0	0	0
4:40 PM	0	0	0	1	1	4:40 PM	0	0	0	0	0	4:40 PM	0	0	0	0	0
4:45 PM	0	0	0	1	1	4:45 PM	0	0	0	0	0	4:45 PM	0	0	0	0	0
4:50 PM	0	0	0	1	1	4:50 PM	0	0	0	0	0	4:50 PM	0	0	0	0	0
4:55 PM	0	0	0	1	1	4:55 PM	0	0	0	0	0	4:55 PM	0	0	0	0	0
5:00 PM	0	0	0	0	0	5:00 PM	0	0	0	0	0	5:00 PM	0	0	0	0	0
5:05 PM	0	0	0	1	1	5:05 PM	0	0	0	0	0	5:05 PM	0	0	0	0	0
5:10 PM	0	1	0	2	3	5:10 PM	0	0	0	0	0	5:10 PM	0	0	0	0	0
5:15 PM	0	0	0	1	1	5:15 PM	0	0	0	0	0	5:15 PM	0	0	0	0	0
5:20 PM	0	0	0	1	1	5:20 PM	0	0	0	0	0	5:20 PM	0	0	0	0	0
5:25 PM	0	0	0	0	0	5:25 PM	0	0	0	0	0	5:25 PM	0	0	0	0	0
5:30 PM	0	1	0	2	3	5:30 PM	0	0	0	0	0	5:30 PM	0	0	0	0	0
5:35 PM	0	0	0	1	1	5:35 PM	0	0	0	0	0	5:35 PM	0	0	0	0	0
5:40 PM	0	0	0	1	1	5:40 PM	0	0	0	0	0	5:40 PM	2	0	0	0	2
5:45 PM	0	0	0	0	0	5:45 PM	0	0	0	0	0	5:45 PM	2	0	0	0	2
5:50 PM	0	0	0	0	0	5:50 PM	0	0	0	0	0	5:50 PM	0	0	0	0	0
5:55 PM	0	0	0	0	0	5:55 PM	0	0	0	0	0	5:55 PM	0	0	0	0	0
Count Total	0	10	0	20	30	Count Total	0	0	0	0	0	Count Total	4	0	0	0	4
Peak Hour	0	2	0	12	14	Peak Hour	0	0	0	0	0	Peak Hour	2	0	0	0	2



(303) 216-2439
www.alltrafficdata.net

Location: 4 SW Wilsonville Rd & SW Advance Rd PM

Date: Thursday, September 30, 2021

Peak Hour: 04:45 PM - 05:45 PM

Peak 15-Minutes: 05:00 PM - 05:15 PM

Peak Hour

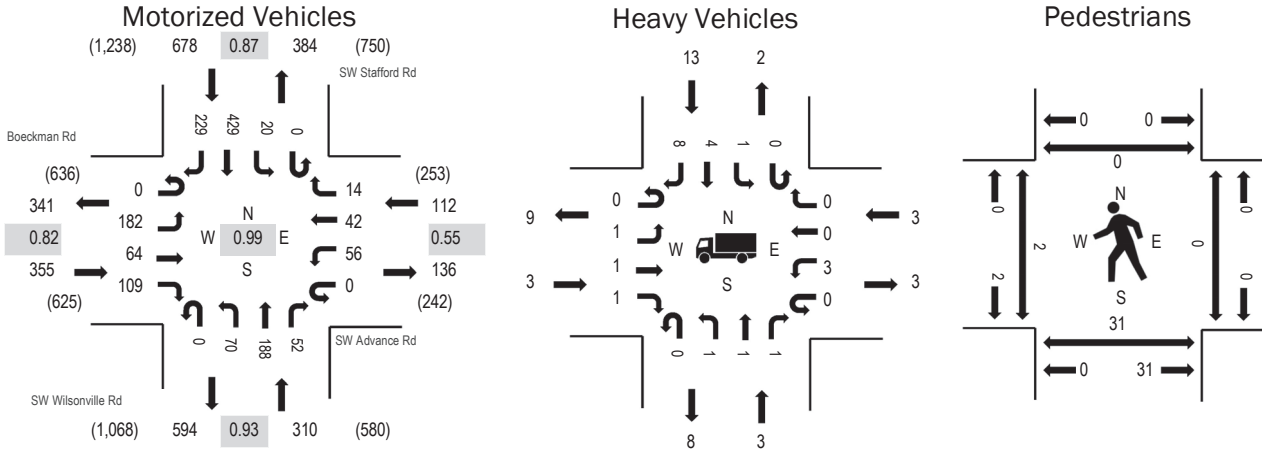

Note: Total study counts contained in parentheses.

	HV%	PHF
EB	0.8%	0.82
WB	2.7%	0.55
NB	1.0%	0.93
SB	1.9%	0.87
All	1.5%	0.99

Traffic Counts - Motorized Vehicles

Interval Start Time	Boeckman Rd Eastbound				SW Advance Rd Westbound				SW Wilsonville Rd Northbound				SW Stafford Rd Southbound				Total	Rolling Hour
	U-Turn	Left	Thru	Right	U-Turn	Left	Thru	Right	U-Turn	Left	Thru	Right	U-Turn	Left	Thru	Right		
4:00 PM	0	11	4	8	0	16	19	12	0	4	14	1	0	5	26	16	136	1,289
4:05 PM	0	16	1	0	0	3	2	3	0	4	20	1	0	2	22	19	93	1,263
4:10 PM	0	17	6	3	0	4	2	6	0	4	16	3	0	0	31	14	106	1,294
4:15 PM	0	10	2	0	0	4	1	3	0	7	14	4	0	0	23	15	83	1,323
4:20 PM	0	20	7	6	0	9	2	5	0	5	13	1	0	0	30	12	110	1,350
4:25 PM	0	12	3	7	0	5	5	3	0	1	18	7	0	3	25	27	116	1,363
4:30 PM	0	11	5	8	0	3	2	0	0	2	10	3	0	1	24	23	92	1,376
4:35 PM	0	18	2	6	0	2	3	2	0	2	14	3	0	3	29	14	98	1,399
4:40 PM	0	11	3	8	0	3	1	4	0	3	14	5	0	1	31	13	97	1,424
4:45 PM	0	15	4	12	0	8	2	0	0	5	17	7	0	0	25	23	118	1,455
4:50 PM	0	15	6	1	0	2	6	2	0	8	15	7	0	2	35	21	120	1,435
4:55 PM	0	16	13	9	0	0	1	2	0	3	9	4	0	1	41	21	120	1,424
5:00 PM	0	19	10	6	0	6	1	0	0	6	16	6	0	2	21	17	110	1,407
5:05 PM	0	12	6	15	0	8	8	5	0	6	15	5	0	1	28	15	124	
5:10 PM	0	23	3	14	0	11	12	2	0	8	15	4	0	2	28	13	135	
5:15 PM	0	14	2	9	0	4	3	1	0	6	14	2	0	3	30	22	110	
5:20 PM	0	7	2	15	0	2	1	0	0	6	22	3	0	1	42	22	123	
5:25 PM	0	13	3	8	0	4	2	0	0	5	19	4	0	2	54	15	129	
5:30 PM	0	15	5	5	0	6	0	0	0	8	16	1	0	2	41	16	115	
5:35 PM	0	16	4	7	0	2	3	2	0	3	16	3	0	2	45	20	123	
5:40 PM	0	17	6	8	0	3	3	0	0	6	14	6	0	2	39	24	128	
5:45 PM	0	7	4	4	0	5	2	2	0	2	13	6	0	0	35	18	98	
5:50 PM	0	13	2	11	0	3	3	0	0	14	11	2	0	3	31	16	109	
5:55 PM	0	8	4	12	0	1	1	0	0	6	15	8	0	1	36	11	103	
Count Total	0	336	107	182	0	114	85	54	0	124	360	96	0	39	772	427	2,696	
Peak Hour	0	182	64	109	0	56	42	14	0	70	188	52	0	20	429	229	1,455	

Traffic Counts - Heavy Vehicles, Bicycles on Road, and Pedestrians/Bicycles on Crosswalk

Interval Start Time	Heavy Vehicles					Interval Start Time	Bicycles on Roadway					Interval Start Time	Pedestrians/Bicycles on Crosswalk				
	EB	NB	WB	SB	Total		EB	NB	WB	SB	Total		EB	NB	WB	SB	Total
4:00 PM	0	0	4	1	5	4:00 PM	0	0	0	0	0	4:00 PM	0	8	0	0	8
4:05 PM	0	0	1	0	1	4:05 PM	0	0	0	0	0	4:05 PM	0	0	0	0	0
4:10 PM	1	2	1	0	4	4:10 PM	0	0	0	0	0	4:10 PM	0	0	0	0	0
4:15 PM	1	1	0	0	2	4:15 PM	0	0	0	0	0	4:15 PM	0	1	0	0	1
4:20 PM	0	4	0	1	5	4:20 PM	0	0	0	0	0	4:20 PM	0	1	0	0	1
4:25 PM	0	1	0	1	2	4:25 PM	0	0	0	0	0	4:25 PM	0	44	0	0	44
4:30 PM	0	0	1	3	4	4:30 PM	0	0	0	0	0	4:30 PM	0	0	0	0	0
4:35 PM	0	0	0	0	0	4:35 PM	0	0	0	0	0	4:35 PM	0	0	0	0	0
4:40 PM	0	0	0	1	1	4:40 PM	0	0	0	0	0	4:40 PM	0	11	0	0	11
4:45 PM	0	0	0	1	1	4:45 PM	0	0	0	0	0	4:45 PM	0	9	0	0	9
4:50 PM	0	0	0	2	2	4:50 PM	0	0	0	0	0	4:50 PM	0	22	0	0	22
4:55 PM	0	1	0	1	2	4:55 PM	0	0	0	0	0	4:55 PM	0	0	0	0	0
5:00 PM	0	0	1	0	1	5:00 PM	0	0	0	0	0	5:00 PM	0	1	0	0	1
5:05 PM	0	0	0	1	1	5:05 PM	0	0	0	0	0	5:05 PM	0	0	0	0	0
5:10 PM	2	0	0	1	3	5:10 PM	0	0	0	0	0	5:10 PM	1	0	0	0	1
5:15 PM	0	0	1	2	3	5:15 PM	0	0	0	0	0	5:15 PM	0	3	0	0	3
5:20 PM	0	0	0	1	1	5:20 PM	0	0	0	0	0	5:20 PM	0	0	0	0	0
5:25 PM	1	0	0	0	1	5:25 PM	0	0	0	0	0	5:25 PM	0	0	0	0	0
5:30 PM	0	2	1	0	3	5:30 PM	0	0	0	0	0	5:30 PM	0	0	0	0	0
5:35 PM	0	0	0	3	3	5:35 PM	0	0	0	0	0	5:35 PM	0	0	0	0	0
5:40 PM	0	0	0	1	1	5:40 PM	0	0	0	0	0	5:40 PM	2	0	0	0	2
5:45 PM	0	0	1	0	1	5:45 PM	0	0	0	0	0	5:45 PM	2	0	0	0	2
5:50 PM	0	0	0	0	0	5:50 PM	0	0	0	0	0	5:50 PM	0	0	0	0	0
5:55 PM	0	0	0	0	0	5:55 PM	0	0	0	0	0	5:55 PM	0	0	0	0	0
Count Total	5	11	11	20	47	Count Total	0	0	0	0	0	Count Total	5	100	0	0	105
Peak Hour	3	3	3	13	22	Peak Hour	0	0	0	0	0	Peak Hour	3	35	0	0	38



(303) 216-2439

www.alltrafficdata.net

Location: 3 Willow Creek Dr & Boeckman Rd PM

Date: Thursday, September 30, 2021

Peak Hour: 04:45 PM - 05:45 PM

Peak 15-Minutes: 05:00 PM - 05:15 PM

Peak Hour

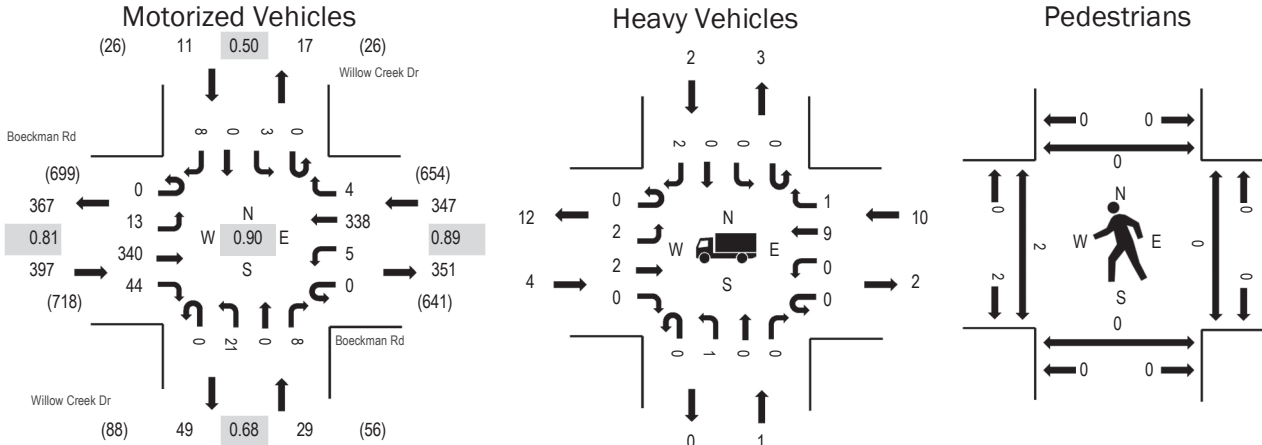

Note: Total study counts contained in parentheses.

	HV%	PHF
EB	1.0%	0.81
WB	2.9%	0.89
NB	3.4%	0.68
SB	18.2%	0.50
All	2.2%	0.90

Traffic Counts - Motorized Vehicles

Interval Start Time	Boeckman Rd Eastbound				Boeckman Rd Westbound				Willow Creek Dr Northbound				Willow Creek Dr Southbound				Total	Rolling Hour
	U-Turn	Left	Thru	Right	U-Turn	Left	Thru	Right	U-Turn	Left	Thru	Right	U-Turn	Left	Thru	Right		
4:00 PM	0	2	19	2	0	0	45	0	0	3	0	0	0	1	0	0	72	700
4:05 PM	0	0	16	2	0	1	23	0	0	3	0	1	0	0	0	0	46	697
4:10 PM	0	0	28	4	0	0	23	0	0	2	0	1	0	0	0	1	59	723
4:15 PM	0	1	24	2	0	0	18	3	0	1	0	0	0	0	0	2	51	741
4:20 PM	0	1	30	2	0	0	18	0	0	2	0	1	0	1	0	2	57	749
4:25 PM	0	1	22	5	0	1	33	0	0	0	0	0	0	1	0	1	64	754
4:30 PM	0	0	23	2	0	0	30	0	0	1	0	0	0	1	0	2	59	736
4:35 PM	0	0	27	1	0	1	18	0	0	1	0	0	0	0	0	1	49	744
4:40 PM	0	0	23	3	0	1	16	0	0	2	0	0	0	0	0	0	45	756
4:45 PM	0	0	29	1	0	1	27	1	0	1	0	1	0	0	0	1	62	784
4:50 PM	0	1	22	3	0	1	33	0	0	3	0	2	0	0	0	2	67	773
4:55 PM	0	1	35	6	0	0	25	0	0	0	0	2	0	0	0	0	69	773
5:00 PM	0	2	36	9	0	0	20	0	0	2	0	0	0	0	0	0	69	754
5:05 PM	0	1	30	2	0	0	36	0	0	2	0	0	0	1	0	0	72	
5:10 PM	0	1	33	7	0	0	34	0	0	2	0	0	0	0	0	0	77	
5:15 PM	0	1	24	3	0	0	27	1	0	2	0	1	0	0	0	0	59	
5:20 PM	0	2	25	0	0	1	31	0	0	1	0	0	0	0	0	2	62	
5:25 PM	0	0	22	0	0	0	20	1	0	1	0	0	0	1	0	1	46	
5:30 PM	0	0	28	8	0	0	28	0	0	1	0	1	0	0	0	1	67	
5:35 PM	0	3	25	2	0	2	25	1	0	3	0	0	0	0	0	0	61	
5:40 PM	0	1	31	3	0	0	32	0	0	3	0	1	0	1	0	1	73	
5:45 PM	0	1	23	2	0	1	20	0	0	3	0	0	0	1	0	0	51	
5:50 PM	0	0	22	4	0	1	35	0	0	4	0	0	0	0	0	1	67	
5:55 PM	0	0	25	4	0	0	19	0	0	2	0	0	0	0	0	0	50	
Count Total	0	19	622	77	0	11	636	7	0	45	0	11	0	8	0	18	1,454	
Peak Hour	0	13	340	44	0	5	338	4	0	21	0	8	0	3	0	8	784	

Traffic Counts - Heavy Vehicles, Bicycles on Road, and Pedestrians/Bicycles on Crosswalk

Interval Start Time	Heavy Vehicles					Interval Start Time	Bicycles on Roadway					Interval Start Time	Pedestrians/Bicycles on Crosswalk				
	EB	NB	WB	SB	Total		EB	NB	WB	SB	Total		EB	NB	WB	SB	Total
4:00 PM	0	0	1	0	1	4:00 PM	0	0	0	0	0	4:00 PM	0	9	0	0	9
4:05 PM	0	0	2	0	2	4:05 PM	0	0	0	0	0	4:05 PM	0	10	0	0	10
4:10 PM	0	0	1	0	1	4:10 PM	0	0	0	0	0	4:10 PM	0	1	0	0	1
4:15 PM	1	0	0	0	1	4:15 PM	0	0	0	0	0	4:15 PM	0	10	0	0	10
4:20 PM	0	0	2	0	2	4:20 PM	0	0	0	0	0	4:20 PM	0	1	0	0	1
4:25 PM	1	0	2	0	3	4:25 PM	0	0	0	0	0	4:25 PM	0	5	0	0	5
4:30 PM	0	0	1	0	1	4:30 PM	0	0	0	0	0	4:30 PM	0	0	0	0	0
4:35 PM	0	0	0	0	0	4:35 PM	0	0	0	0	0	4:35 PM	0	3	0	0	3
4:40 PM	0	0	0	0	0	4:40 PM	0	0	0	0	0	4:40 PM	0	0	0	0	0
4:45 PM	0	0	1	0	1	4:45 PM	0	0	0	0	0	4:45 PM	0	0	0	0	0
4:50 PM	0	0	1	1	2	4:50 PM	0	0	0	0	0	4:50 PM	0	0	0	0	0
4:55 PM	0	0	0	0	0	4:55 PM	0	0	0	0	0	4:55 PM	0	0	0	0	0
5:00 PM	1	0	0	0	1	5:00 PM	0	0	0	0	0	5:00 PM	0	0	0	0	0
5:05 PM	0	0	1	0	1	5:05 PM	0	0	0	0	0	5:05 PM	0	0	0	0	0
5:10 PM	2	1	1	0	4	5:10 PM	0	0	0	0	0	5:10 PM	0	0	0	0	0
5:15 PM	0	0	1	0	1	5:15 PM	0	0	0	0	0	5:15 PM	0	0	0	0	0
5:20 PM	1	0	1	0	2	5:20 PM	0	0	0	0	0	5:20 PM	0	0	0	0	0
5:25 PM	0	0	0	0	0	5:25 PM	0	0	0	0	0	5:25 PM	0	0	0	0	0
5:30 PM	0	0	1	1	2	5:30 PM	0	0	0	0	0	5:30 PM	0	0	0	0	0
5:35 PM	0	0	3	0	3	5:35 PM	0	0	0	0	0	5:35 PM	0	0	0	0	0
5:40 PM	0	0	0	0	0	5:40 PM	0	0	0	0	0	5:40 PM	2	0	0	0	2
5:45 PM	0	0	0	0	0	5:45 PM	0	0	0	0	0	5:45 PM	2	0	0	0	2
5:50 PM	0	0	0	1	1	5:50 PM	0	0	0	0	0	5:50 PM	0	1	0	0	1
5:55 PM	0	0	0	0	0	5:55 PM	0	0	0	0	0	5:55 PM	0	0	0	0	0
Count Total	6	1	19	3	29	Count Total	0	0	0	0	0	Count Total	4	40	0	0	44
Peak Hour	4	1	10	2	17	Peak Hour	0	0	0	0	0	Peak Hour	2	0	0	0	2



(303) 216-2439
www.alltrafficdata.net

Location: 2 SW Canyon Creek Rd & Boeckman Rd PM

Date: Thursday, September 30, 2021

Peak Hour: 04:45 PM - 05:45 PM

Peak 15-Minutes: 04:50 PM - 05:05 PM

Peak Hour

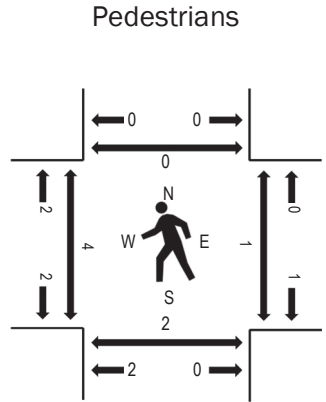
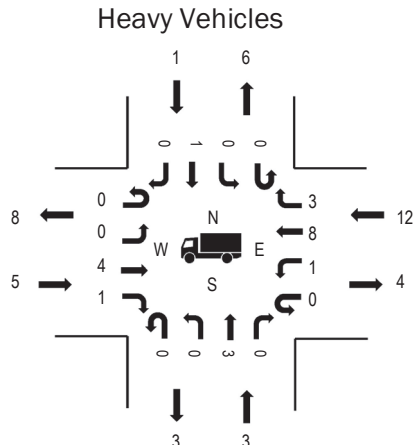
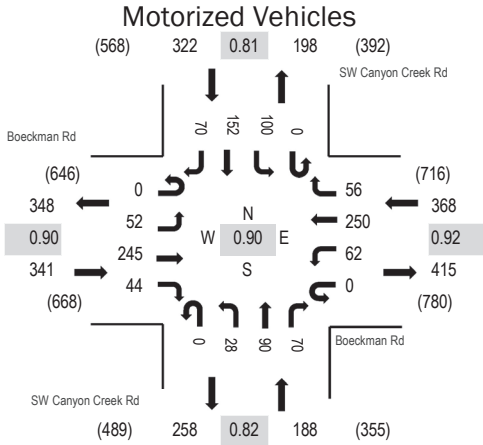

Note: Total study counts contained in parentheses.

	HV%	PHF
EB	1.5%	0.90
WB	3.3%	0.92
NB	1.6%	0.82
SB	0.3%	0.81
All	1.7%	0.90

Traffic Counts - Motorized Vehicles

Interval Start Time	Boeckman Rd Eastbound				Boeckman Rd Westbound				SW Canyon Creek Rd Northbound				SW Canyon Creek Rd Southbound				Total	Rolling Hour
	U-Turn	Left	Thru	Right	U-Turn	Left	Thru	Right	U-Turn	Left	Thru	Right	U-Turn	Left	Thru	Right		
4:00 PM	0	6	17	8	0	11	31	4	0	4	5	2	0	5	9	4	106	1,142
4:05 PM	0	4	22	2	0	4	18	7	0	0	8	6	0	2	9	1	83	1,148
4:10 PM	0	5	21	3	0	3	20	4	0	1	5	5	0	3	15	7	92	1,172
4:15 PM	0	5	14	3	0	2	15	5	0	2	15	6	0	8	7	3	85	1,184
4:20 PM	0	2	28	2	0	4	14	6	0	2	11	4	0	5	15	3	96	1,201
4:25 PM	0	3	19	7	0	7	22	4	0	3	7	4	0	7	9	2	94	1,201
4:30 PM	0	3	23	3	0	8	21	4	0	2	4	5	0	7	5	9	94	1,202
4:35 PM	0	4	22	5	0	2	19	5	0	3	10	1	0	3	13	3	90	1,214
4:40 PM	0	3	19	2	0	6	12	3	0	3	8	4	0	11	14	7	92	1,215
4:45 PM	0	3	18	4	0	1	20	3	0	3	5	3	0	9	9	7	85	1,219
4:50 PM	0	8	12	4	0	5	31	6	0	2	9	5	0	12	16	3	113	1,214
4:55 PM	0	7	25	2	0	6	19	3	0	3	7	8	0	9	13	10	112	1,190
5:00 PM	0	5	22	0	0	2	12	6	0	5	9	11	0	16	15	9	112	1,165
5:05 PM	0	2	27	7	0	8	24	6	0	1	7	3	0	9	10	3	107	
5:10 PM	0	3	21	6	0	8	20	5	0	1	11	4	0	6	12	7	104	
5:15 PM	0	7	19	3	0	4	20	6	0	3	10	7	0	6	14	3	102	
5:20 PM	0	5	14	5	0	7	23	7	0	3	4	5	0	6	11	6	96	
5:25 PM	0	4	19	6	0	7	18	5	0	2	3	3	0	7	16	5	95	
5:30 PM	0	2	25	5	0	3	20	3	0	1	10	7	0	10	11	9	106	
5:35 PM	0	3	21	1	0	6	17	5	0	3	8	5	0	4	17	1	91	
5:40 PM	0	3	22	1	0	5	26	1	0	1	7	9	0	6	8	7	96	
5:45 PM	0	1	21	3	0	7	20	2	0	2	8	6	0	6	2	2	80	
5:50 PM	0	2	16	4	0	5	20	6	0	0	11	2	0	10	10	3	89	
5:55 PM	0	4	19	2	0	6	16	5	0	0	5	3	0	9	14	4	87	
Count Total	0	94	486	88	0	127	478	111	0	50	187	118	0	176	274	118	2,307	
Peak Hour	0	52	245	44	0	62	250	56	0	28	90	70	0	100	152	70	1,219	

Traffic Counts - Heavy Vehicles, Bicycles on Road, and Pedestrians/Bicycles on Crosswalk

Interval Start Time	Heavy Vehicles					Interval Start Time	Bicycles on Roadway					Interval Start Time	Pedestrians/Bicycles on Crosswalk				
	EB	NB	WB	SB	Total		EB	NB	WB	SB	Total		EB	NB	WB	SB	Total
4:00 PM	0	0	3	0	3	4:00 PM	0	0	0	0	0	4:00 PM	0	0	0	0	0
4:05 PM	0	2	2	0	4	4:05 PM	0	0	0	0	0	4:05 PM	0	0	0	0	0
4:10 PM	1	0	1	0	2	4:10 PM	0	0	0	0	0	4:10 PM	0	2	0	0	2
4:15 PM	1	1	0	1	3	4:15 PM	0	0	0	0	0	4:15 PM	1	2	2	0	5
4:20 PM	0	1	1	0	2	4:20 PM	0	0	0	0	0	4:20 PM	0	0	0	0	0
4:25 PM	1	0	2	0	3	4:25 PM	0	0	0	0	0	4:25 PM	0	0	0	0	0
4:30 PM	1	0	2	0	3	4:30 PM	0	0	0	0	0	4:30 PM	0	2	0	0	2
4:35 PM	0	0	0	0	0	4:35 PM	0	0	0	0	0	4:35 PM	0	0	2	0	2
4:40 PM	0	0	0	0	0	4:40 PM	0	0	0	1	1	4:40 PM	0	0	0	0	0
4:45 PM	0	0	1	0	1	4:45 PM	0	0	0	0	0	4:45 PM	0	0	0	0	0
4:50 PM	0	0	1	0	1	4:50 PM	0	0	0	1	1	4:50 PM	0	0	0	0	0
4:55 PM	0	0	0	0	0	4:55 PM	0	0	0	0	0	4:55 PM	0	0	0	0	0
5:00 PM	1	0	0	0	1	5:00 PM	0	0	0	0	0	5:00 PM	0	1	0	0	1
5:05 PM	1	0	0	0	1	5:05 PM	0	0	0	0	0	5:05 PM	1	0	0	0	1
5:10 PM	1	0	1	0	2	5:10 PM	0	0	0	0	0	5:10 PM	0	0	0	0	0
5:15 PM	0	0	1	1	2	5:15 PM	0	0	0	0	0	5:15 PM	1	0	0	0	1
5:20 PM	2	0	2	0	4	5:20 PM	0	0	0	0	0	5:20 PM	0	1	0	0	1
5:25 PM	0	0	1	0	1	5:25 PM	0	0	0	0	0	5:25 PM	0	0	0	0	0
5:30 PM	0	1	2	0	3	5:30 PM	0	0	0	0	0	5:30 PM	0	0	0	0	0
5:35 PM	0	2	3	0	5	5:35 PM	0	0	0	0	0	5:35 PM	0	0	1	0	1
5:40 PM	0	0	0	0	0	5:40 PM	0	0	0	0	0	5:40 PM	2	0	0	0	2
5:45 PM	0	0	0	0	0	5:45 PM	0	0	0	0	0	5:45 PM	2	0	0	0	2
5:50 PM	0	0	0	0	0	5:50 PM	0	0	0	0	0	5:50 PM	0	1	0	0	1
5:55 PM	0	0	0	0	0	5:55 PM	0	0	0	0	0	5:55 PM	0	0	0	0	0
Count Total	9	7	23	2	41	Count Total	0	0	0	2	2	Count Total	7	9	5	0	21
Peak Hour	5	3	12	1	21	Peak Hour	0	0	0	1	1	Peak Hour	4	2	1	0	7



(303) 216-2439

www.alltrafficdata.net

Location: 1 SW Parkway Ave & Boeckman Rd PM

Date: Thursday, September 30, 2021

Peak Hour: 04:15 PM - 05:15 PM

Peak 15-Minutes: 04:45 PM - 05:00 PM

Peak Hour

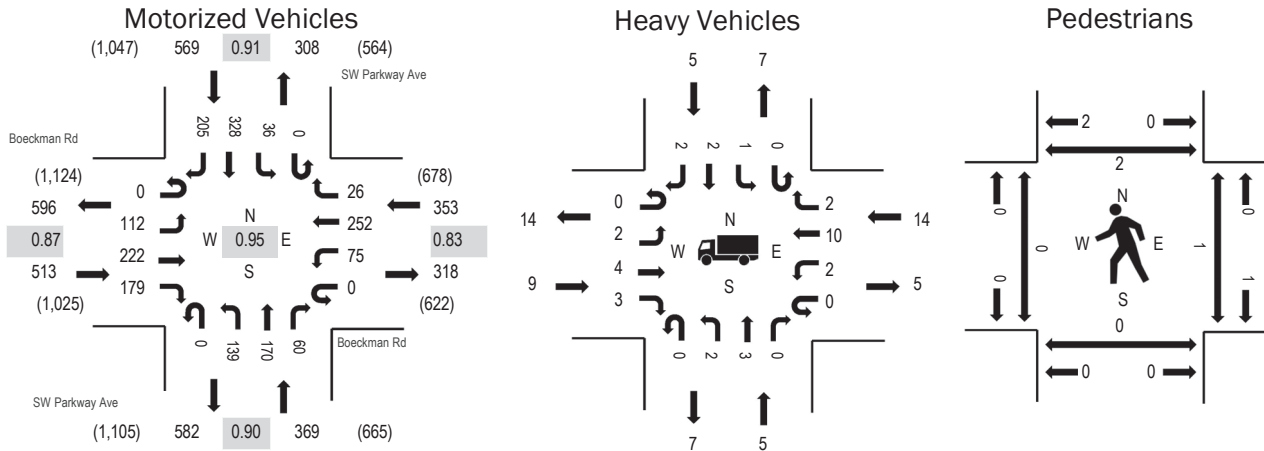

Note: Total study counts contained in parentheses.

	HV%	PHF
EB	1.8%	0.87
WB	4.0%	0.83
NB	1.4%	0.90
SB	0.9%	0.91
All	1.8%	0.95

Traffic Counts - Motorized Vehicles

Interval Start Time	Boeckman Rd Eastbound				Boeckman Rd Westbound				SW Parkway Ave Northbound				SW Parkway Ave Southbound				Total	Rolling Hour
	U-Turn	Left	Thru	Right	U-Turn	Left	Thru	Right	U-Turn	Left	Thru	Right	U-Turn	Left	Thru	Right		
4:00 PM	0	7	20	16	0	4	20	4	0	11	20	3	0	5	25	23	158	1,795
4:05 PM	0	14	15	21	0	4	22	4	0	17	5	4	0	4	17	19	146	1,774
4:10 PM	0	11	27	22	0	1	27	1	0	11	14	4	0	1	26	4	149	1,803
4:15 PM	0	12	18	20	0	9	16	0	0	7	4	4	0	3	25	13	131	1,804
4:20 PM	0	6	22	16	0	6	19	3	0	15	13	6	0	5	19	12	142	1,799
4:25 PM	0	10	13	8	0	6	12	2	0	12	16	10	0	4	35	19	147	1,802
4:30 PM	0	8	20	19	0	6	20	1	0	13	13	6	0	1	25	19	151	1,783
4:35 PM	0	5	16	18	0	8	17	2	0	10	12	4	0	2	31	24	149	1,762
4:40 PM	0	11	18	19	0	7	16	1	0	14	16	2	0	2	23	20	149	1,771
4:45 PM	0	10	19	11	0	6	19	4	0	9	19	4	0	1	37	15	154	1,745
4:50 PM	0	11	16	14	0	6	30	1	0	10	17	5	0	1	34	20	165	1,718
4:55 PM	0	11	20	10	0	5	32	1	0	14	15	5	0	2	25	14	154	1,661
5:00 PM	0	4	17	10	0	8	23	6	0	9	14	5	0	2	22	17	137	1,620
5:05 PM	0	14	25	24	0	2	19	3	0	9	18	5	0	6	31	19	175	
5:10 PM	0	10	18	10	0	6	29	2	0	17	13	4	0	7	21	13	150	
5:15 PM	0	4	15	12	0	3	15	1	0	12	8	2	0	6	35	13	126	
5:20 PM	0	12	20	12	0	5	35	4	0	5	12	1	0	2	17	20	145	
5:25 PM	0	5	18	11	0	5	17	2	0	11	6	6	0	3	30	14	128	
5:30 PM	0	7	20	19	0	5	16	0	0	10	13	3	0	3	27	7	130	
5:35 PM	0	12	18	20	0	5	24	1	0	13	14	8	0	3	24	16	158	
5:40 PM	0	6	14	11	0	6	21	4	0	5	14	4	0	3	20	15	123	
5:45 PM	0	7	22	13	0	9	19	0	0	7	11	1	0	2	19	17	127	
5:50 PM	0	8	15	14	0	5	17	2	0	8	6	2	0	1	17	13	108	
5:55 PM	0	5	21	18	0	6	10	1	0	7	11	7	0	1	19	7	113	
Count Total	0	210	447	368	0	133	495	50	0	256	304	105	0	70	604	373	3,415	
Peak Hour	0	112	222	179	0	75	252	26	0	139	170	60	0	36	328	205	1,804	

Traffic Counts - Heavy Vehicles, Bicycles on Road, and Pedestrians/Bicycles on Crosswalk

Interval Start Time	Heavy Vehicles					Interval Start Time	Bicycles on Roadway					Interval Start Time	Pedestrians/Bicycles on Crosswalk				
	EB	NB	WB	SB	Total		EB	NB	WB	SB	Total		EB	NB	WB	SB	Total
4:00 PM	0	2	2	0	4	4:00 PM	0	0	0	0	0	4:00 PM	0	0	0	0	0
4:05 PM	2	0	1	0	3	4:05 PM	0	0	0	0	0	4:05 PM	0	0	0	0	0
4:10 PM	3	1	2	0	6	4:10 PM	0	0	0	0	0	4:10 PM	0	0	0	0	0
4:15 PM	0	0	3	1	4	4:15 PM	0	0	0	0	0	4:15 PM	0	0	0	0	0
4:20 PM	2	1	4	0	7	4:20 PM	0	0	0	0	0	4:20 PM	0	0	0	2	2
4:25 PM	0	0	2	1	3	4:25 PM	0	0	0	0	0	4:25 PM	0	0	0	0	0
4:30 PM	1	1	1	0	3	4:30 PM	0	0	0	0	0	4:30 PM	0	0	0	0	0
4:35 PM	2	0	0	1	3	4:35 PM	0	0	0	0	0	4:35 PM	0	0	0	0	0
4:40 PM	0	1	0	1	2	4:40 PM	0	0	0	0	0	4:40 PM	0	0	0	0	0
4:45 PM	0	1	2	0	3	4:45 PM	0	0	0	0	0	4:45 PM	0	0	0	0	0
4:50 PM	0	1	1	1	3	4:50 PM	0	0	0	0	0	4:50 PM	0	0	1	0	1
4:55 PM	0	0	0	0	0	4:55 PM	0	0	0	0	0	4:55 PM	0	0	0	0	0
5:00 PM	1	0	0	0	1	5:00 PM	0	0	0	0	0	5:00 PM	0	0	0	0	0
5:05 PM	2	0	0	0	2	5:05 PM	0	0	0	0	0	5:05 PM	0	0	0	0	0
5:10 PM	1	0	1	0	2	5:10 PM	0	0	0	0	0	5:10 PM	0	0	0	0	0
5:15 PM	0	0	2	0	2	5:15 PM	0	0	0	0	0	5:15 PM	0	0	0	1	1
5:20 PM	1	2	3	0	6	5:20 PM	0	0	0	0	0	5:20 PM	0	0	0	0	0
5:25 PM	0	0	1	1	2	5:25 PM	0	0	0	0	0	5:25 PM	0	0	1	0	1
5:30 PM	0	0	0	0	0	5:30 PM	0	0	0	0	0	5:30 PM	0	0	1	0	1
5:35 PM	1	0	4	0	5	5:35 PM	0	0	0	0	0	5:35 PM	0	0	0	0	0
5:40 PM	0	1	1	0	2	5:40 PM	0	0	0	0	0	5:40 PM	1	0	0	0	1
5:45 PM	0	1	0	0	1	5:45 PM	0	0	0	0	0	5:45 PM	0	0	0	0	0
5:50 PM	0	0	2	0	2	5:50 PM	0	0	0	0	0	5:50 PM	0	0	0	0	0
5:55 PM	0	0	0	0	0	5:55 PM	0	0	0	0	0	5:55 PM	0	0	0	0	0
Count Total	16	12	32	6	66	Count Total	0	0	0	0	0	Count Total	1	0	3	3	7
Peak Hour	9	5	14	5	33	Peak Hour	0	0	0	0	0	Peak Hour	0	0	1	2	3



B. HCM REPORTS – EXISTING

Intersection						
Int Delay, s/veh	0.1					
Movement	EBL	EBR	NBL	NBT	SBT	SBR
Lane Configurations						
Traffic Vol, veh/h	1	4	0	396	679	2
Future Vol, veh/h	1	4	0	396	679	2
Conflicting Peds, #/hr	0	0	2	0	0	2
Sign Control	Stop	Stop	Free	Free	Free	Free
RT Channelized	-	None	-	None	-	None
Storage Length	0	-	-	-	-	-
Veh in Median Storage, #	0	-	-	0	0	-
Grade, %	0	-	-	0	0	-
Peak Hour Factor	92	92	92	92	92	92
Heavy Vehicles, %	0	0	0	0	2	50
Mvmt Flow	1	4	0	430	738	2

Major/Minor	Minor2	Major1	Major2			
Conflicting Flow All	1171	741	742	0	-	0
Stage 1	741	-	-	-	-	-
Stage 2	430	-	-	-	-	-
Critical Hdwy	6.4	6.2	4.1	-	-	-
Critical Hdwy Stg 1	5.4	-	-	-	-	-
Critical Hdwy Stg 2	5.4	-	-	-	-	-
Follow-up Hdwy	3.5	3.3	2.2	-	-	-
Pot Cap-1 Maneuver	215	420	874	-	-	-
Stage 1	475	-	-	-	-	-
Stage 2	660	-	-	-	-	-
Platoon blocked, %				-	-	-
Mov Cap-1 Maneuver	214	419	873	-	-	-
Mov Cap-2 Maneuver	214	-	-	-	-	-
Stage 1	474	-	-	-	-	-
Stage 2	659	-	-	-	-	-

Approach	EB	NB	SB
HCM Control Delay, s	15.4	0	0
HCM LOS	C		

Minor Lane/Major Mvmt	NBL	NBT	EBLn1	SBT	SBR
Capacity (veh/h)	873	-	352	-	-
HCM Lane V/C Ratio	-	-	0.015	-	-
HCM Control Delay (s)	0	-	15.4	-	-
HCM Lane LOS	A	-	C	-	-
HCM 95th %tile Q(veh)	0	-	0	-	-

Intersection						
Int Delay, s/veh	0.4					
Movement	EBL	EBR	NBL	NBT	SBT	SBR
Lane Configurations						
Traffic Vol, veh/h	12	6	4	384	672	11
Future Vol, veh/h	12	6	4	384	672	11
Conflicting Peds, #/hr	0	0	2	0	0	2
Sign Control	Stop	Stop	Free	Free	Free	Free
RT Channelized	-	None	-	None	-	None
Storage Length	0	-	-	-	-	-
Veh in Median Storage, #	0	-	-	0	0	-
Grade, %	0	-	-	0	0	-
Peak Hour Factor	92	92	92	92	92	92
Heavy Vehicles, %	0	0	25	0	2	0
Mvmt Flow	13	7	4	417	730	12





















Major/Minor	Minor2	Major1	Major2			
Conflicting Flow All	1163	738	744	0	-	0
Stage 1	738	-	-	-	-	-
Stage 2	425	-	-	-	-	-
Critical Hdwy	6.4	6.2	4.35	-	-	-
Critical Hdwy Stg 1	5.4	-	-	-	-	-
Critical Hdwy Stg 2	5.4	-	-	-	-	-
Follow-up Hdwy	3.5	3.3	2.425	-	-	-
Pot Cap-1 Maneuver	217	421	768	-	-	-
Stage 1	476	-	-	-	-	-
Stage 2	664	-	-	-	-	-
Platoon blocked, %				-	-	-
Mov Cap-1 Maneuver	215	420	767	-	-	-
Mov Cap-2 Maneuver	215	-	-	-	-	-
Stage 1	472	-	-	-	-	-
Stage 2	663	-	-	-	-	-

Approach	EB	NB	SB
HCM Control Delay, s	20.2	0.1	0
HCM LOS	C		

Minor Lane/Major Mvmt	NBL	NBT	EBLn1	SBT	SBR
Capacity (veh/h)	767	-	257	-	-
HCM Lane V/C Ratio	0.006	-	0.076	-	-
HCM Control Delay (s)	9.7	0	20.2	-	-
HCM Lane LOS	A	A	C	-	-
HCM 95th %tile Q(veh)	0	-	0.2	-	-

HCM 6th Signalized Intersection Summary
 3: Wilsonville Rd/Stafford Rd & Boeckman Rd/Advance Rd

Frog Pond Oaks
 Existing PM

												
Movement	EBL	EBT	EBR	WBL	WBT	WBR	NBL	NBT	NBR	SBL	SBT	SBR
Lane Configurations												
Traffic Volume (veh/h)	182	62	109	56	45	14	70	192	52	20	429	229
Future Volume (veh/h)	182	62	109	56	45	14	70	192	52	20	429	229
Initial Q (Qb), veh	0	0	0	0	0	0	0	0	0	0	0	0
Ped-Bike Adj(A_pbT)	0.93		0.91	0.90		0.89	1.00		0.97	1.00		1.00
Parking Bus, Adj	1.00	1.00	1.00	1.00	1.00	1.00	1.00	1.00	1.00	1.00	1.00	1.00
Work Zone On Approach		No			No			No			No	
Adj Sat Flow, veh/h/ln	1885	1870	1885	1826	1900	1900	1885	1885	1870	1826	1885	1856
Adj Flow Rate, veh/h	184	63	19	57	45	1	71	194	44	20	433	212
Peak Hour Factor	0.99	0.99	0.99	0.99	0.99	0.99	0.99	0.99	0.99	0.99	0.99	0.99
Percent Heavy Veh, %	1	2	1	5	0	0	1	1	2	5	1	3
Cap, veh/h	462	395	305	344	259	6	268	664	151	552	505	247
Arrive On Green	0.11	0.21	0.21	0.04	0.14	0.14	0.04	0.45	0.45	0.02	0.42	0.42
Sat Flow, veh/h	1795	1870	1448	1739	1846	41	1795	1479	335	1739	1194	585
Grp Volume(v), veh/h	184	63	19	57	0	46	71	0	238	20	0	645
Grp Sat Flow(s),veh/h/ln	1795	1870	1448	1739	0	1887	1795	0	1814	1739	0	1778
Q Serve(g_s), s	5.2	1.8	0.7	1.8	0.0	1.4	1.4	0.0	5.3	0.4	0.0	21.0
Cycle Q Clear(g_c), s	5.2	1.8	0.7	1.8	0.0	1.4	1.4	0.0	5.3	0.4	0.0	21.0
Prop In Lane	1.00		1.00	1.00		0.02	1.00		0.18	1.00		0.33
Lane Grp Cap(c), veh/h	462	395	305	344	0	265	268	0	814	552	0	752
V/C Ratio(X)	0.40	0.16	0.06	0.17	0.00	0.17	0.27	0.00	0.29	0.04	0.00	0.86
Avail Cap(c_a), veh/h	531	764	591	387	0	611	302	0	1070	631	0	1049
HCM Platoon Ratio	1.00	1.00	1.00	1.00	1.00	1.00	1.00	1.00	1.00	1.00	1.00	1.00
Upstream Filter(I)	1.00	1.00	1.00	1.00	0.00	1.00	1.00	0.00	1.00	1.00	0.00	1.00
Uniform Delay (d), s/veh	18.5	20.6	20.2	22.2	0.0	24.2	13.2	0.0	11.2	10.2	0.0	16.7
Incr Delay (d2), s/veh	0.6	0.2	0.1	0.2	0.0	0.3	0.5	0.0	0.2	0.0	0.0	5.3
Initial Q Delay(d3),s/veh	0.0	0.0	0.0	0.0	0.0	0.0	0.0	0.0	0.0	0.0	0.0	0.0
%ile BackOfQ(50%),veh/ln	2.1	0.7	0.2	0.7	0.0	0.6	0.5	0.0	1.9	0.1	0.0	8.5
Unsig. Movement Delay, s/veh												
LnGrp Delay(d),s/veh	19.0	20.8	20.2	22.4	0.0	24.5	13.7	0.0	11.4	10.2	0.0	22.0
LnGrp LOS	B	C	C	C	A	C	B	A	B	B	A	C
Approach Vol, veh/h		266			103			309			665	
Approach Delay, s/veh		19.5			23.4			11.9			21.6	
Approach LOS		B			C			B			C	
Timer - Assigned Phs	1	2	3	4	5	6	7	8				
Phs Duration (G+Y+Rc), s	7.4	31.5	11.6	13.5	5.7	33.2	7.0	18.0				
Change Period (Y+Rc), s	4.5	4.5	4.5	4.5	4.5	4.5	4.5	4.5				
Max Green Setting (Gmax), s	4.1	37.7	9.5	20.7	4.1	37.7	4.1	26.1				
Max Q Clear Time (g_c+I1), s	3.4	23.0	7.2	3.4	2.4	7.3	3.8	3.8				
Green Ext Time (p_c), s	0.0	4.0	0.1	0.1	0.0	1.5	0.0	0.3				
Intersection Summary												
HCM 6th Ctrl Delay				19.1								
HCM 6th LOS				B								

Intersection												
Int Delay, s/veh	1											
Movement	EBL	EBT	EBR	WBL	WBT	WBR	NBL	NBT	NBR	SBL	SBT	SBR
Lane Configurations		↕			↕			↕			↕	
Traffic Vol, veh/h	13	342	44	5	335	4	21	0	8	3	0	8
Future Vol, veh/h	13	342	44	5	335	4	21	0	8	3	0	8
Conflicting Peds, #/hr	0	0	0	0	0	0	2	0	0	0	0	2
Sign Control	Free	Free	Free	Free	Free	Free	Stop	Stop	Stop	Stop	Stop	Stop
RT Channelized	-	-	None	-	-	None	-	-	None	-	-	None
Storage Length	-	-	-	-	-	-	-	-	-	-	-	-
Veh in Median Storage, #	-	0	-	-	0	-	-	0	-	-	0	-
Grade, %	-	0	-	-	0	-	-	0	-	-	0	-
Peak Hour Factor	90	90	90	90	90	90	90	90	90	90	90	90
Heavy Vehicles, %	15	1	0	0	3	25	5	0	0	0	0	25
Mvmt Flow	14	380	49	6	372	4	23	0	9	3	0	9

Major/Minor	Major1			Major2			Minor1			Minor2		
Conflicting Flow All	376	0	0	429	0	0	826	821	405	823	843	376
Stage 1	-	-	-	-	-	-	433	433	-	386	386	-
Stage 2	-	-	-	-	-	-	393	388	-	437	457	-
Critical Hdwy	4.25	-	-	4.1	-	-	7.15	6.5	6.2	7.1	6.5	6.45
Critical Hdwy Stg 1	-	-	-	-	-	-	6.15	5.5	-	6.1	5.5	-
Critical Hdwy Stg 2	-	-	-	-	-	-	6.15	5.5	-	6.1	5.5	-
Follow-up Hdwy	2.335	-	-	2.2	-	-	3.545	4	3.3	3.5	4	3.525
Pot Cap-1 Maneuver	1115	-	-	1141	-	-	288	312	650	295	303	622
Stage 1	-	-	-	-	-	-	595	585	-	641	614	-
Stage 2	-	-	-	-	-	-	626	612	-	602	571	-
Platoon blocked, %		-	-		-	-						
Mov Cap-1 Maneuver	1115	-	-	1141	-	-	278	305	650	286	296	621
Mov Cap-2 Maneuver	-	-	-	-	-	-	278	305	-	286	296	-
Stage 1	-	-	-	-	-	-	585	575	-	630	610	-
Stage 2	-	-	-	-	-	-	612	608	-	584	561	-

Approach	EB			WB			NB			SB		
HCM Control Delay, s	0.3			0.1			17.1			12.8		
HCM LOS							C			B		

Minor Lane/Major Mvmt	NBLn1	EBL	EBT	EBR	WBL	WBT	WBR	SBLn1
Capacity (veh/h)	330	1115	-	-	1141	-	-	471
HCM Lane V/C Ratio	0.098	0.013	-	-	0.005	-	-	0.026
HCM Control Delay (s)	17.1	8.3	0	-	8.2	0	-	12.8
HCM Lane LOS	C	A	A	-	A	A	-	B
HCM 95th %tile Q(veh)	0.3	0	-	-	0	-	-	0.1

Intersection	
Intersection Delay, s/veh	19.4
Intersection LOS	C

Movement	EBL	EBT	EBR	WBL	WBT	WBR	NBL	NBT	NBR	SBL	SBT	SBR
Lane Configurations	↶	↷		↶	↷		↶	↷		↶	↷	
Traffic Vol, veh/h	52	245	44	62	250	56	28	90	70	100	152	70
Future Vol, veh/h	52	245	44	62	250	56	28	90	70	100	152	70
Peak Hour Factor	0.90	0.90	0.90	0.90	0.90	0.90	0.90	0.90	0.90	0.90	0.90	0.90
Heavy Vehicles, %	0	2	2	2	3	5	0	3	0	0	1	0
Mvmt Flow	58	272	49	69	278	62	31	100	78	111	169	78
Number of Lanes	1	1	0	1	1	0	1	1	0	1	1	0

Approach	EB	WB	NB	SB
Opposing Approach	WB	EB	SB	NB
Opposing Lanes	2	2	2	2
Conflicting Approach Left	SB	NB	EB	WB
Conflicting Lanes Left	2	2	2	2
Conflicting Approach Right	NB	SB	WB	EB
Conflicting Lanes Right	2	2	2	2
HCM Control Delay	21.3	22.5	14.8	16.5
HCM LOS	C	C	B	C

Lane	NBLn1	NBLn2	EBLn1	EBLn2	WBLn1	WBLn2	SBLn1	SBLn2
Vol Left, %	100%	0%	100%	0%	100%	0%	100%	0%
Vol Thru, %	0%	56%	0%	85%	0%	82%	0%	68%
Vol Right, %	0%	44%	0%	15%	0%	18%	0%	32%
Sign Control	Stop	Stop	Stop	Stop	Stop	Stop	Stop	Stop
Traffic Vol by Lane	28	160	52	289	62	306	100	222
LT Vol	28	0	52	0	62	0	100	0
Through Vol	0	90	0	245	0	250	0	152
RT Vol	0	70	0	44	0	56	0	70
Lane Flow Rate	31	178	58	321	69	340	111	247
Geometry Grp	7	7	7	7	7	7	7	7
Degree of Util (X)	0.074	0.382	0.127	0.653	0.151	0.686	0.252	0.51
Departure Headway (Hd)	8.522	7.742	7.914	7.326	7.891	7.264	8.163	7.439
Convergence, Y/N	Yes	Yes	Yes	Yes	Yes	Yes	Yes	Yes
Cap	419	462	452	491	453	496	439	483
Service Time	6.305	5.524	5.687	5.099	5.664	5.037	5.937	5.212
HCM Lane V/C Ratio	0.074	0.385	0.128	0.654	0.152	0.685	0.253	0.511
HCM Control Delay	12	15.3	11.8	23	12.1	24.6	13.7	17.8
HCM Lane LOS	B	C	B	C	B	C	B	C
HCM 95th-tile Q	0.2	1.8	0.4	4.6	0.5	5.2	1	2.8

HCM 6th Signalized Intersection Summary
6: Parkway Ave & Boeckman Rd

Frog Pond Oaks
Existing PM



Movement	EBL	EBT	EBR	WBL	WBT	WBR	NBL	NBT	NBR	SBL	SBT	SBR
Lane Configurations												
Traffic Volume (veh/h)	112	222	179	75	252	26	139	170	60	36	328	205
Future Volume (veh/h)	112	222	179	75	252	26	139	170	60	36	328	205
Initial Q (Qb), veh	0	0	0	0	0	0	0	0	0	0	0	0
Ped-Bike Adj(A_pbT)	1.00		1.00	1.00		1.00	1.00		1.00	1.00		1.00
Parking Bus, Adj	1.00	1.00	1.00	1.00	1.00	1.00	1.00	1.00	1.00	1.00	1.00	1.00
Work Zone On Approach		No			No			No			No	
Adj Sat Flow, veh/h/ln	1870	1870	1870	1856	1841	1781	1885	1870	1900	1856	1885	1885
Adj Flow Rate, veh/h	118	234	155	79	265	23	146	179	49	38	345	190
Peak Hour Factor	0.95	0.95	0.95	0.95	0.95	0.95	0.95	0.95	0.95	0.95	0.95	0.95
Percent Heavy Veh, %	2	2	2	3	4	8	1	2	0	3	1	1
Cap, veh/h	343	277	183	247	404	35	310	565	155	520	405	223
Arrive On Green	0.07	0.26	0.26	0.05	0.24	0.24	0.08	0.40	0.40	0.03	0.35	0.35
Sat Flow, veh/h	1781	1048	694	1767	1669	145	1795	1413	387	1767	1142	629
Grp Volume(v), veh/h	118	0	389	79	0	288	146	0	228	38	0	535
Grp Sat Flow(s),veh/h/ln	1781	0	1742	1767	0	1814	1795	0	1800	1767	0	1771
Q Serve(g_s), s	3.2	0.0	14.0	2.2	0.0	9.5	3.3	0.0	5.8	0.9	0.0	18.5
Cycle Q Clear(g_c), s	3.2	0.0	14.0	2.2	0.0	9.5	3.3	0.0	5.8	0.9	0.0	18.5
Prop In Lane	1.00		0.40	1.00		0.08	1.00		0.21	1.00		0.36
Lane Grp Cap(c), veh/h	343	0	460	247	0	439	310	0	720	520	0	629
V/C Ratio(X)	0.34	0.00	0.85	0.32	0.00	0.66	0.47	0.00	0.32	0.07	0.00	0.85
Avail Cap(c_a), veh/h	432	0	618	374	0	644	392	0	911	680	0	896
HCM Platoon Ratio	1.00	1.00	1.00	1.00	1.00	1.00	1.00	1.00	1.00	1.00	1.00	1.00
Upstream Filter(I)	1.00	0.00	1.00	1.00	0.00	1.00	1.00	0.00	1.00	1.00	0.00	1.00
Uniform Delay (d), s/veh	17.5	0.0	23.1	18.7	0.0	22.6	14.5	0.0	13.7	12.8	0.0	19.7
Incr Delay (d2), s/veh	0.6	0.0	8.1	0.7	0.0	1.7	1.1	0.0	0.3	0.1	0.0	5.6
Initial Q Delay(d3),s/veh	0.0	0.0	0.0	0.0	0.0	0.0	0.0	0.0	0.0	0.0	0.0	0.0
%ile BackOfQ(50%),veh/ln	1.3	0.0	6.4	0.9	0.0	4.0	1.3	0.0	2.2	0.3	0.0	7.8
Unsig. Movement Delay, s/veh												
LnGrp Delay(d),s/veh	18.1	0.0	31.1	19.4	0.0	24.3	15.6	0.0	13.9	12.9	0.0	25.3
LnGrp LOS	B	A	C	B	A	C	B	A	B	B	A	C
Approach Vol, veh/h		507			367			374			573	
Approach Delay, s/veh		28.1			23.2			14.6			24.5	
Approach LOS		C			C			B			C	
Timer - Assigned Phs	1	2	3	4	5	6	7	8				
Phs Duration (G+Y+Rc), s	9.0	28.0	7.2	22.0	6.0	31.0	8.7	20.5				
Change Period (Y+Rc), s	4.0	4.5	4.0	4.5	4.0	4.5	4.0	4.5				
Max Green Setting (Gmax), s	33.5	33.5	8.0	23.5	8.0	33.5	8.0	23.5				
Max Q Clear Time (g_c+1/3), s	20.5	20.5	4.2	16.0	2.9	7.8	5.2	11.5				
Green Ext Time (p_c), s	0.1	3.0	0.0	1.4	0.0	1.3	0.1	1.3				
Intersection Summary												
HCM 6th Ctrl Delay												23.2
HCM 6th LOS												C

Synchro ID	Control Type	Intersection	Control Type	LOS	Delay	V/C Ratio
	3 Signal	Wilsonville Rd/Stafford Rd & Boeckman R	Signal	B	19.1	0.66
	6 Signal	Parkway Ave & Boeckman Rd	Signal	C	23.2	0.80

C. STAGE II LIST

Stage II Approved

Updated by D. Pauly 09.21.2021

Stage II Approved									
Project	Land Use	Status	Size	Total PM Peak Trips	Trip Allocation Percentage		Net New (Primary + Diverted) PM Peak Hour Trips not yet active		
					Internal	Pass-By	In	Out	Total
Hydro-Temp: Recent agreement with the City, the project is vested and so are the traffic trips	Office/Flex-Space	Not built	60.8 KSF				44	46	90
Mercedes Benz (Phase 2)	Auto Dealership	Not built					20	26	46
Shredding Systems (SQFT does not including paint canopy and another canopy)	Industrial/Commercial	Under construction	66.8 KSF				20	46	66
Town Center Ph III and trip dedication to Miller Paint store Uses marked with "*" have not been built and PM peak hr trip sum exceeds remaining vested trip level by 2 trips. It has yet to be determined how to allocate trips between remaining buildings.	*High Turnover Restaurant (Pad 1)	Not built	7.5 KSF				24	17	47*
	Remaining Approved Total								47
Wilsonville Road Business Park Phase II	Phase 2 - office (2-story building on west parcel)	Partially Built	21.7 KSF				15	71	86
Frog Pond-Stafford Meadows (Phase 2 and 3a of 10/18 study)	Residential	Partially Built, 24 homes built and occupied	46 units				12	10	22
Frog Pond-Frog Pond Meadows (Phase 3B, 4A, 4B of 10/18 Study)	Residential	Partially Built, 3 homes built and occupied	74 units				44	27	71
Frog Pond Ridge	Residential	Under construction, no homes built	71 units				43	28	71
Frog Pond-Morgan Farm	Residential	Partially Built, 38 homes built and occupied	80 units				28	14	42
Fir Avenue Commons	Residential	Partially Built, 2 homes built and occupied	10 units				6	2	8
Magnolia Townhomes	Residential	Under construction	6 units				3	2	5
Aspen Meadows II	Residential	Under construction, no homes sold and occupied	5 units				2	3	5
Canyon Creek III	Residential	Approved	5 units (traffic study was for 11)				2	3	5
Coffee Creek Logistics	Industrial/Commercial	Under construction	115K				16	41	57

Stage II Approved – Villebois													
Project	Phase	Status	Land Use					Total PM Peak Trips	Trip Allocation Percentage		Net New (Primary + Diverted) PM Peak Hour Trips not yet active		
			SF	Town.	Apt.	Retail	School		Internal	Pass-By	In	Out	Total
North (Entirety)	Residential	Partially built, 364 homes sold and occupied	466								65	37	102
Central	Residential	Partially Built, 735 homes (102 single family, 319 condo/row homes, 365 apartments) occupied	102	391	365	8.5 KSF					30	13	43
FOR REFERENCE SAP EAST CE SAP SOUTH (Includes PDP 7 Grande Pointe)			537	42									

Pending Projects for Which Traffic Analysis has been completed (except Villebois)										
Project	Land Use	Status	Size	Total PM Peak	Trip Allocation Percentage			Net New (Primary) PM Peak Hour Trips		
					Internal	Pass-By	Diverted	In	Out	Total
PW Complex on Boberg	Public	under review	15,800 office, 17,900 warehouse					11	39	50
DAS North Valley Complex	Public/Industria	under review	174,700 sf					5	15	20
Frog Pond Crossing								19	9	28
Boones Ferry Gas Station/Conve	Commercail	under review	3,460 sf store, 12 g	240		134		53	53	106

Sort	Import Counts	Export	imports new ATD format													Total Vehicle Volumes					
						Northbound			Southbound			Eastbound			Westbound						
			Count	Date	ak Hr St	NBL	NBT	NBR	SBL	SBT	SBR	EBL	EBT	EBR	WBL	WBT	WBR				
40	Stage II Trips (New Trip Distribution)																				
41	6	SW Stafford Rd & SW Frog Pond Ln PM				7	25				33	16	10		4						
42	5	SW Stafford Rd & SW Brisbane St PM				6	23				21	16	9		4						
43	4	SW Wilsonville Rd & SW Advance Rd PM				4	11	1		4	7	14	11	8	4		9	7			
44	3	Willow Creek Dr & Boeckman Rd PM								5		19	31	18			19	8			
45	2	SW Canyon Creek Rd & Boeckman Rd PM				2	1	5	10	2	4	5	34	3	3	3	29	6			
46	1	SW Parkway Ave & Boeckman Rd PM				2	1	6	4	1	7	5	32	2	4	4	28	3			
50	Stage II Trips - Crossing Trips																				
51	6	SW Stafford Rd & SW Frog Pond Ln PM				3						10	5		2						
52	5	SW Stafford Rd & SW Brisbane St PM					3			2											
53	4	SW Wilsonville Rd & SW Advance Rd PM					1			1	1		1					1			
54	3	Willow Creek Dr & Boeckman Rd PM									5	6	1								
55	2	SW Canyon Creek Rd & Boeckman Rd PM						1	1					5		1	3	1			
56	1	SW Parkway Ave & Boeckman Rd PM						1	1					3		1	1	1			
60	Stage II Trips - Vista Trips																				
61	6	SW Stafford Rd & SW Frog Pond Ln PM				4						13	8		3						
62	5	SW Stafford Rd & SW Brisbane St PM					4			3											
63	4	SW Wilsonville Rd & SW Advance Rd PM				1	2			1	1	1	1		1		1	1			
64	3	Willow Creek Dr & Boeckman Rd PM								1		5	8	1			1	2			
65	2	SW Canyon Creek Rd & Boeckman Rd PM						1	1					7		1	4	1			
66	1	SW Parkway Ave & Boeckman Rd PM						1	1					5		1	2	1			
70	Stage II Trips - Estates Trips																				
71	6	SW Stafford Rd & SW Frog Pond Ln PM				1	1			1	4	2									
72	5	SW Stafford Rd & SW Brisbane St PM				1	1				1	1			1						
73	4	SW Wilsonville Rd & SW Advance Rd PM				1	1				1				1			1			
74	3	Willow Creek Dr & Boeckman Rd PM								1		2	3					1			
75	2	SW Canyon Creek Rd & Boeckman Rd PM						1	1					1		1		1			
76	1	SW Parkway Ave & Boeckman Rd PM												1							

D. HCM REPORTS – EXISTING + PROJECT

Intersection						
Int Delay, s/veh	0.3					
Movement	EBL	EBR	NBL	NBT	SBT	SBR
Lane Configurations	T			T		T
Traffic Vol, veh/h	9	6	3	396	679	15
Future Vol, veh/h	9	6	3	396	679	15
Conflicting Peds, #/hr	0	0	2	0	0	2
Sign Control	Stop	Stop	Free	Free	Free	Free
RT Channelized	-	None	-	None	-	None
Storage Length	0	-	-	-	-	-
Veh in Median Storage, #	0	-	-	0	0	-
Grade, %	0	-	-	0	0	-
Peak Hour Factor	92	92	92	92	92	92
Heavy Vehicles, %	0	0	0	0	2	50
Mvmt Flow	10	7	3	430	738	16

Major/Minor	Minor2	Major1	Major2			
Conflicting Flow All	1184	748	756	0	-	0
Stage 1	748	-	-	-	-	-
Stage 2	436	-	-	-	-	-
Critical Hdwy	6.4	6.2	4.1	-	-	-
Critical Hdwy Stg 1	5.4	-	-	-	-	-
Critical Hdwy Stg 2	5.4	-	-	-	-	-
Follow-up Hdwy	3.5	3.3	2.2	-	-	-
Pot Cap-1 Maneuver	211	416	864	-	-	-
Stage 1	471	-	-	-	-	-
Stage 2	656	-	-	-	-	-
Platoon blocked, %				-	-	-
Mov Cap-1 Maneuver	209	415	863	-	-	-
Mov Cap-2 Maneuver	209	-	-	-	-	-
Stage 1	468	-	-	-	-	-
Stage 2	655	-	-	-	-	-

Approach	EB	NB	SB
HCM Control Delay, s	19.7	0.1	0
HCM LOS	C		

Minor Lane/Major Mvmt	NBL	NBT	EBLn1	SBT	SBR
Capacity (veh/h)	863	-	261	-	-
HCM Lane V/C Ratio	0.004	-	0.062	-	-
HCM Control Delay (s)	9.2	0	19.7	-	-
HCM Lane LOS	A	A	C	-	-
HCM 95th %tile Q(veh)	0	-	0.2	-	-

Intersection						
Int Delay, s/veh	0.4					
Movement	EBL	EBR	NBL	NBT	SBT	SBR
Lane Configurations						
Traffic Vol, veh/h	12	6	4	387	674	11
Future Vol, veh/h	12	6	4	387	674	11
Conflicting Peds, #/hr	0	0	2	0	0	2
Sign Control	Stop	Stop	Free	Free	Free	Free
RT Channelized	-	None	-	None	-	None
Storage Length	0	-	-	-	-	-
Veh in Median Storage, #	0	-	-	0	0	-
Grade, %	0	-	-	0	0	-
Peak Hour Factor	92	92	92	92	92	92
Heavy Vehicles, %	0	0	25	0	2	0
Mvmt Flow	13	7	4	421	733	12

Major/Minor	Minor2	Major1		Major2	
Conflicting Flow All	1170	741	747	0	0
Stage 1	741	-	-	-	-
Stage 2	429	-	-	-	-
Critical Hdwy	6.4	6.2	4.35	-	-
Critical Hdwy Stg 1	5.4	-	-	-	-
Critical Hdwy Stg 2	5.4	-	-	-	-
Follow-up Hdwy	3.5	3.3	2.425	-	-
Pot Cap-1 Maneuver	215	420	766	-	-
Stage 1	475	-	-	-	-
Stage 2	661	-	-	-	-
Platoon blocked, %				-	-
Mov Cap-1 Maneuver	213	419	765	-	-
Mov Cap-2 Maneuver	213	-	-	-	-
Stage 1	471	-	-	-	-
Stage 2	660	-	-	-	-

Approach	EB	NB	SB
HCM Control Delay, s	20.3	0.1	0
HCM LOS	C		

Minor Lane/Major Mvmt	NBL	NBT	EBLn1	SBT	SBR
Capacity (veh/h)	765	-	255	-	-
HCM Lane V/C Ratio	0.006	-	0.077	-	-
HCM Control Delay (s)	9.7	0	20.3	-	-
HCM Lane LOS	A	A	C	-	-
HCM 95th %tile Q(veh)	0	-	0.2	-	-

HCM 6th Signalized Intersection Summary
 3: Wilsonville Rd/Stafford Rd & Boeckman Rd/Advance Rd

Frog Pond Oaks
 Existing PM + Project



Movement	EBL	EBT	EBR	WBL	WBT	WBR	NBL	NBT	NBR	SBL	SBT	SBR
Lane Configurations												
Traffic Volume (veh/h)	182	62	110	56	45	15	71	194	52	21	430	229
Future Volume (veh/h)	182	62	110	56	45	15	71	194	52	21	430	229
Initial Q (Qb), veh	0	0	0	0	0	0	0	0	0	0	0	0
Ped-Bike Adj(A_pbT)	0.93		0.91	0.90		0.89	1.00		0.97	1.00		1.00
Parking Bus, Adj	1.00	1.00	1.00	1.00	1.00	1.00	1.00	1.00	1.00	1.00	1.00	1.00
Work Zone On Approach		No			No			No			No	
Adj Sat Flow, veh/h/ln	1885	1870	1885	1826	1900	1900	1885	1885	1870	1826	1885	1856
Adj Flow Rate, veh/h	184	63	19	57	45	1	72	196	44	21	434	212
Peak Hour Factor	0.99	0.99	0.99	0.99	0.99	0.99	0.99	0.99	0.99	0.99	0.99	0.99
Percent Heavy Veh, %	1	2	1	5	0	0	1	1	2	5	1	3
Cap, veh/h	462	394	305	344	259	6	268	665	149	552	506	247
Arrive On Green	0.11	0.21	0.21	0.04	0.14	0.14	0.05	0.45	0.45	0.02	0.42	0.42
Sat Flow, veh/h	1795	1870	1448	1739	1846	41	1795	1482	333	1739	1195	584
Grp Volume(v), veh/h	184	63	19	57	0	46	72	0	240	21	0	646
Grp Sat Flow(s),veh/h/ln	1795	1870	1448	1739	0	1887	1795	0	1815	1739	0	1778
Q Serve(g_s), s	5.2	1.8	0.7	1.8	0.0	1.4	1.4	0.0	5.4	0.4	0.0	21.1
Cycle Q Clear(g_c), s	5.2	1.8	0.7	1.8	0.0	1.4	1.4	0.0	5.4	0.4	0.0	21.1
Prop In Lane	1.00		1.00	1.00		0.02	1.00		0.18	1.00		0.33
Lane Grp Cap(c), veh/h	462	394	305	344	0	264	268	0	814	552	0	752
V/C Ratio(X)	0.40	0.16	0.06	0.17	0.00	0.17	0.27	0.00	0.29	0.04	0.00	0.86
Avail Cap(c_a), veh/h	530	763	590	386	0	610	302	0	1069	629	0	1047
HCM Platoon Ratio	1.00	1.00	1.00	1.00	1.00	1.00	1.00	1.00	1.00	1.00	1.00	1.00
Upstream Filter(l)	1.00	1.00	1.00	1.00	0.00	1.00	1.00	0.00	1.00	1.00	0.00	1.00
Uniform Delay (d), s/veh	18.5	20.6	20.2	22.3	0.0	24.3	13.2	0.0	11.2	10.2	0.0	16.7
Incr Delay (d2), s/veh	0.6	0.2	0.1	0.2	0.0	0.3	0.5	0.0	0.2	0.0	0.0	5.3
Initial Q Delay(d3),s/veh	0.0	0.0	0.0	0.0	0.0	0.0	0.0	0.0	0.0	0.0	0.0	0.0
%ile BackOfQ(50%),veh/ln	2.1	0.7	0.2	0.7	0.0	0.6	0.5	0.0	2.0	0.2	0.0	8.6
Unsig. Movement Delay, s/veh												
LnGrp Delay(d),s/veh	19.1	20.8	20.3	22.5	0.0	24.6	13.8	0.0	11.4	10.2	0.0	22.1
LnGrp LOS	B	C	C	C	A	C	B	A	B	B	A	C
Approach Vol, veh/h		266			103			312				667
Approach Delay, s/veh		19.6			23.4			12.0				21.7
Approach LOS		B			C			B				C
Timer - Assigned Phs	1	2	3	4	5	6	7	8				
Phs Duration (G+Y+Rc), s	7.4	31.6	11.6	13.5	5.7	33.2	7.0	18.0				
Change Period (Y+Rc), s	4.5	4.5	4.5	4.5	4.5	4.5	4.5	4.5				
Max Green Setting (Gmax), s	4.1	37.7	9.5	20.7	4.1	37.7	4.1	26.1				
Max Q Clear Time (g_c+I1), s	3.4	23.1	7.2	3.4	2.4	7.4	3.8	3.8				
Green Ext Time (p_c), s	0.0	4.0	0.1	0.1	0.0	1.5	0.0	0.3				

Intersection Summary

HCM 6th Ctrl Delay			19.2									
HCM 6th LOS			B									

Intersection												
Int Delay, s/veh	1.2											
Movement	EBL	EBT	EBR	WBL	WBT	WBR	NBL	NBT	NBR	SBL	SBT	SBR
Lane Configurations		↕			↕			↕			↕	
Traffic Vol, veh/h	22	342	44	5	335	5	21	0	8	4	0	13
Future Vol, veh/h	22	342	44	5	335	5	21	0	8	4	0	13
Conflicting Peds, #/hr	0	0	0	0	0	0	2	0	0	0	0	2
Sign Control	Free	Free	Free	Free	Free	Free	Stop	Stop	Stop	Stop	Stop	Stop
RT Channelized	-	-	None	-	-	None	-	-	None	-	-	None
Storage Length	-	-	-	-	-	-	-	-	-	-	-	-
Veh in Median Storage, #	-	0	-	-	0	-	-	0	-	-	0	-
Grade, %	-	0	-	-	0	-	-	0	-	-	0	-
Peak Hour Factor	90	90	90	90	90	90	90	90	90	90	90	90
Heavy Vehicles, %	15	1	0	0	3	25	5	0	0	0	0	25
Mvmt Flow	24	380	49	6	372	6	23	0	9	4	0	14

Major/Minor	Major1			Major2			Minor1			Minor2		
Conflicting Flow All	378	0	0	429	0	0	849	843	405	844	864	377
Stage 1	-	-	-	-	-	-	453	453	-	387	387	-
Stage 2	-	-	-	-	-	-	396	390	-	457	477	-
Critical Hdwy	4.25	-	-	4.1	-	-	7.15	6.5	6.2	7.1	6.5	6.45
Critical Hdwy Stg 1	-	-	-	-	-	-	6.15	5.5	-	6.1	5.5	-
Critical Hdwy Stg 2	-	-	-	-	-	-	6.15	5.5	-	6.1	5.5	-
Follow-up Hdwy	2.335	-	-	2.2	-	-	3.545	4	3.3	3.5	4	3.525
Pot Cap-1 Maneuver	1113	-	-	1141	-	-	278	303	650	285	294	622
Stage 1	-	-	-	-	-	-	581	573	-	641	613	-
Stage 2	-	-	-	-	-	-	623	611	-	587	559	-
Platoon blocked, %	-	-	-	-	-	-	-	-	-	-	-	-
Mov Cap-1 Maneuver	1113	-	-	1141	-	-	264	292	650	273	283	621
Mov Cap-2 Maneuver	-	-	-	-	-	-	264	292	-	273	283	-
Stage 1	-	-	-	-	-	-	564	556	-	622	609	-
Stage 2	-	-	-	-	-	-	603	607	-	562	543	-

Approach	EB			WB			NB			SB		
HCM Control Delay, s	0.4			0.1			17.7			12.8		
HCM LOS							C			B		

Minor Lane/Major Mvmt	NBLn1	EBL	EBT	EBR	WBL	WBT	WBR	SBLn1
Capacity (veh/h)	316	1113	-	-	1141	-	-	478
HCM Lane V/C Ratio	0.102	0.022	-	-	0.005	-	-	0.04
HCM Control Delay (s)	17.7	8.3	0	-	8.2	0	-	12.8
HCM Lane LOS	C	A	A	-	A	A	-	B
HCM 95th %tile Q(veh)	0.3	0.1	-	-	0	-	-	0.1

Intersection	
Intersection Delay, s/veh	20
Intersection LOS	C

Movement	EBL	EBT	EBR	WBL	WBT	WBR	NBL	NBT	NBR	SBL	SBT	SBR
Lane Configurations	↶	↷		↶	↷		↶	↷		↶	↷	
Traffic Vol, veh/h	52	252	44	63	253	57	28	90	71	101	152	70
Future Vol, veh/h	52	252	44	63	253	57	28	90	71	101	152	70
Peak Hour Factor	0.90	0.90	0.90	0.90	0.90	0.90	0.90	0.90	0.90	0.90	0.90	0.90
Heavy Vehicles, %	0	2	2	2	3	5	0	3	0	0	1	0
Mvmt Flow	58	280	49	70	281	63	31	100	79	112	169	78
Number of Lanes	1	1	0	1	1	0	1	1	0	1	1	0

Approach	EB	WB	NB	SB
Opposing Approach	WB	EB	SB	NB
Opposing Lanes	2	2	2	2
Conflicting Approach Left	SB	NB	EB	WB
Conflicting Lanes Left	2	2	2	2
Conflicting Approach Right	NB	SB	WB	EB
Conflicting Lanes Right	2	2	2	2
HCM Control Delay	22.3	23.3	15	16.7
HCM LOS	C	C	B	C

Lane	NBLn1	NBLn2	EBLn1	EBLn2	WBLn1	WBLn2	SBLn1	SBLn2
Vol Left, %	100%	0%	100%	0%	100%	0%	100%	0%
Vol Thru, %	0%	56%	0%	85%	0%	82%	0%	68%
Vol Right, %	0%	44%	0%	15%	0%	18%	0%	32%
Sign Control	Stop	Stop	Stop	Stop	Stop	Stop	Stop	Stop
Traffic Vol by Lane	28	161	52	296	63	310	101	222
LT Vol	28	0	52	0	63	0	101	0
Through Vol	0	90	0	252	0	253	0	152
RT Vol	0	71	0	44	0	57	0	70
Lane Flow Rate	31	179	58	329	70	344	112	247
Geometry Grp	7	7	7	7	7	7	7	7
Degree of Util (X)	0.074	0.388	0.128	0.673	0.154	0.699	0.256	0.514
Departure Headway (Hd)	8.588	7.805	7.952	7.366	7.936	7.308	8.224	7.499
Convergence, Y/N	Yes	Yes	Yes	Yes	Yes	Yes	Yes	Yes
Cap	416	460	450	490	450	493	435	479
Service Time	6.374	5.59	5.729	5.142	5.713	5.084	6.002	5.277
HCM Lane V/C Ratio	0.075	0.389	0.129	0.671	0.156	0.698	0.257	0.516
HCM Control Delay	12.1	15.5	11.9	24.1	12.2	25.5	13.8	18
HCM Lane LOS	B	C	B	C	B	D	B	C
HCM 95th-tile Q	0.2	1.8	0.4	4.9	0.5	5.4	1	2.9

HCM 6th Signalized Intersection Summary

6: Parkway Ave & Boeckman Rd

Frog Pond Oaks
Existing PM + Project



Movement	EBL	EBT	EBR	WBL	WBT	WBR	NBL	NBT	NBR	SBL	SBT	SBR
Lane Configurations												
Traffic Volume (veh/h)	112	227	179	76	253	27	139	170	61	37	328	205
Future Volume (veh/h)	112	227	179	76	253	27	139	170	61	37	328	205
Initial Q (Qb), veh	0	0	0	0	0	0	0	0	0	0	0	0
Ped-Bike Adj(A_pbT)	1.00		1.00	1.00		1.00	1.00		1.00	1.00		1.00
Parking Bus, Adj	1.00	1.00	1.00	1.00	1.00	1.00	1.00	1.00	1.00	1.00	1.00	1.00
Work Zone On Approach		No			No			No			No	
Adj Sat Flow, veh/h/ln	1870	1870	1870	1856	1841	1781	1885	1870	1900	1856	1885	1885
Adj Flow Rate, veh/h	118	239	154	80	266	24	146	179	50	39	345	190
Peak Hour Factor	0.95	0.95	0.95	0.95	0.95	0.95	0.95	0.95	0.95	0.95	0.95	0.95
Percent Heavy Veh, %	2	2	2	3	4	8	1	2	0	3	1	1
Cap, veh/h	343	282	181	247	406	37	309	561	157	518	405	223
Arrive On Green	0.07	0.27	0.27	0.05	0.24	0.24	0.08	0.40	0.40	0.03	0.35	0.35
Sat Flow, veh/h	1781	1061	684	1767	1663	150	1795	1406	393	1767	1142	629
Grp Volume(v), veh/h	118	0	393	80	0	290	146	0	229	39	0	535
Grp Sat Flow(s),veh/h/ln	1781	0	1744	1767	0	1813	1795	0	1799	1767	0	1771
Q Serve(g_s), s	3.2	0.0	14.2	2.2	0.0	9.6	3.3	0.0	5.8	0.9	0.0	18.6
Cycle Q Clear(g_c), s	3.2	0.0	14.2	2.2	0.0	9.6	3.3	0.0	5.8	0.9	0.0	18.6
Prop In Lane	1.00		0.39	1.00		0.08	1.00		0.22	1.00		0.36
Lane Grp Cap(c), veh/h	343	0	463	247	0	443	309	0	717	518	0	628
V/C Ratio(X)	0.34	0.00	0.85	0.32	0.00	0.65	0.47	0.00	0.32	0.08	0.00	0.85
Avail Cap(c_a), veh/h	431	0	616	371	0	640	390	0	905	676	0	891
HCM Platoon Ratio	1.00	1.00	1.00	1.00	1.00	1.00	1.00	1.00	1.00	1.00	1.00	1.00
Upstream Filter(I)	1.00	0.00	1.00	1.00	0.00	1.00	1.00	0.00	1.00	1.00	0.00	1.00
Uniform Delay (d), s/veh	17.5	0.0	23.2	18.7	0.0	22.6	14.6	0.0	13.8	12.9	0.0	19.9
Incr Delay (d2), s/veh	0.6	0.0	8.4	0.8	0.0	1.6	1.1	0.0	0.3	0.1	0.0	5.7
Initial Q Delay(d3),s/veh	0.0	0.0	0.0	0.0	0.0	0.0	0.0	0.0	0.0	0.0	0.0	0.0
%ile BackOfQ(50%),veh/ln	1.3	0.0	6.5	0.9	0.0	4.0	1.3	0.0	2.2	0.3	0.0	7.9
Unsig. Movement Delay, s/veh												
LnGrp Delay(d),s/veh	18.1	0.0	31.6	19.5	0.0	24.3	15.8	0.0	14.0	13.0	0.0	25.6
LnGrp LOS	B	A	C	B	A	C	B	A	B	B	A	C
Approach Vol, veh/h		511			370			375			574	
Approach Delay, s/veh		28.5			23.2			14.7			24.7	
Approach LOS		C			C			B			C	
Timer - Assigned Phs	1	2	3	4	5	6	7	8				
Phs Duration (G+Y+Rc), s	9.0	28.1	7.3	22.2	6.1	31.1	8.7	20.8				
Change Period (Y+Rc), s	4.0	4.5	4.0	4.5	4.0	4.5	4.0	4.5				
Max Green Setting (Gmax), s	33.5	33.5	8.0	23.5	8.0	33.5	8.0	23.5				
Max Q Clear Time (g_c+1/3), s	20.6	20.6	4.2	16.2	2.9	7.8	5.2	11.6				
Green Ext Time (p_c), s	0.1	3.0	0.0	1.4	0.0	1.4	0.1	1.3				
Intersection Summary												
HCM 6th Ctrl Delay			23.4									
HCM 6th LOS			C									

Synchro ID	Control Type	Intersection	Control Type	LOS	Delay	V/C Ratio
	3 Signal	Wilsonville Rd/Stafford Rd & Boeckman R	Signal	B	19.2	0.66
	6 Signal	Parkway Ave & Boeckman Rd	Signal	C	23.4	0.81

E. HCM REPORTS – EXISTING + STAGE II

Intersection						
Int Delay, s/veh	0.9					
Movement	EBL	EBR	NBL	NBT	SBT	SBR
Lane Configurations	T		T		T	
Traffic Vol, veh/h	26	13	15	422	713	45
Future Vol, veh/h	26	13	15	422	713	45
Conflicting Peds, #/hr	0	0	2	0	0	2
Sign Control	Stop	Stop	Free	Free	Free	Free
RT Channelized	-	None	-	None	-	None
Storage Length	0	-	-	-	-	-
Veh in Median Storage, #	0	-	-	0	0	-
Grade, %	0	-	-	0	0	-
Peak Hour Factor	92	92	92	92	92	92
Heavy Vehicles, %	0	0	0	0	2	50
Mvmt Flow	28	14	16	459	775	49

Major/Minor	Minor2	Major1	Major2			
Conflicting Flow All	1293	802	826	0	-	0
Stage 1	802	-	-	-	-	-
Stage 2	491	-	-	-	-	-
Critical Hdwy	6.4	6.2	4.1	-	-	-
Critical Hdwy Stg 1	5.4	-	-	-	-	-
Critical Hdwy Stg 2	5.4	-	-	-	-	-
Follow-up Hdwy	3.5	3.3	2.2	-	-	-
Pot Cap-1 Maneuver	181	387	813	-	-	-
Stage 1	445	-	-	-	-	-
Stage 2	619	-	-	-	-	-
Platoon blocked, %				-	-	-
Mov Cap-1 Maneuver	176	386	812	-	-	-
Mov Cap-2 Maneuver	176	-	-	-	-	-
Stage 1	433	-	-	-	-	-
Stage 2	618	-	-	-	-	-

Approach	EB	NB	SB
HCM Control Delay, s	25.8	0.3	0
HCM LOS	D		

Minor Lane/Major Mvmt	NBL	NBT	EBLn1	SBT	SBR
Capacity (veh/h)	812	-	215	-	-
HCM Lane V/C Ratio	0.02	-	0.197	-	-
HCM Control Delay (s)	9.5	0	25.8	-	-
HCM Lane LOS	A	A	D	-	-
HCM 95th %tile Q(veh)	0.1	-	0.7	-	-

Intersection						
Int Delay, s/veh	0.8					
Movement	EBL	EBR	NBL	NBT	SBT	SBR
Lane Configurations						
Traffic Vol, veh/h	22	11	11	415	698	28
Future Vol, veh/h	22	11	11	415	698	28
Conflicting Peds, #/hr	0	0	2	0	0	2
Sign Control	Stop	Stop	Free	Free	Free	Free
RT Channelized	-	None	-	None	-	None
Storage Length	0	-	-	-	-	-
Veh in Median Storage, #	0	-	-	0	0	-
Grade, %	0	-	-	0	0	-
Peak Hour Factor	92	92	92	92	92	92
Heavy Vehicles, %	0	0	25	0	2	0
Mvmt Flow	24	12	12	451	759	30

Major/Minor	Minor2	Major1		Major2	
Conflicting Flow All	1251	776	791	0	0
Stage 1	776	-	-	-	-
Stage 2	475	-	-	-	-
Critical Hdwy	6.4	6.2	4.35	-	-
Critical Hdwy Stg 1	5.4	-	-	-	-
Critical Hdwy Stg 2	5.4	-	-	-	-
Follow-up Hdwy	3.5	3.3	2.425	-	-
Pot Cap-1 Maneuver	192	401	736	-	-
Stage 1	457	-	-	-	-
Stage 2	630	-	-	-	-
Platoon blocked, %				-	-
Mov Cap-1 Maneuver	187	400	735	-	-
Mov Cap-2 Maneuver	187	-	-	-	-
Stage 1	446	-	-	-	-
Stage 2	629	-	-	-	-

Approach	EB	NB	SB
HCM Control Delay, s	23.8	0.3	0
HCM LOS	C		

Minor Lane/Major Mvmt	NBL	NBT	EBLn1	SBT	SBR
Capacity (veh/h)	735	-	227	-	-
HCM Lane V/C Ratio	0.016	-	0.158	-	-
HCM Control Delay (s)	10	0	23.8	-	-
HCM Lane LOS	A	A	C	-	-
HCM 95th %tile Q(veh)	0.1	-	0.6	-	-

HCM 6th Signalized Intersection Summary
 3: Wilsonville Rd/Stafford Rd & Boeckman Rd/Advance Rd

Frog Pond Oaks
 Existing PM + Stage II



Movement	EBL	EBT	EBR	WBL	WBT	WBR	NBL	NBT	NBR	SBL	SBT	SBR
Lane Configurations												
Traffic Volume (veh/h)	195	70	115	56	55	24	76	207	53	26	439	244
Future Volume (veh/h)	195	70	115	56	55	24	76	207	53	26	439	244
Initial Q (Qb), veh	0	0	0	0	0	0	0	0	0	0	0	0
Ped-Bike Adj(A_pbT)	0.93		0.91	0.90		0.88	1.00		0.97	1.00		1.00
Parking Bus, Adj	1.00	1.00	1.00	1.00	1.00	1.00	1.00	1.00	1.00	1.00	1.00	1.00
Work Zone On Approach		No			No			No			No	
Adj Sat Flow, veh/h/ln	1885	1870	1885	1826	1900	1900	1885	1885	1870	1826	1885	1856
Adj Flow Rate, veh/h	197	71	23	57	56	5	77	209	45	26	443	226
Peak Hour Factor	0.99	0.99	0.99	0.99	0.99	0.99	0.99	0.99	0.99	0.99	0.99	0.99
Percent Heavy Veh, %	1	2	1	5	0	0	1	1	2	5	1	3
Cap, veh/h	448	394	305	328	225	20	260	681	147	551	509	260
Arrive On Green	0.12	0.21	0.21	0.04	0.13	0.13	0.05	0.46	0.46	0.02	0.43	0.43
Sat Flow, veh/h	1795	1870	1448	1739	1697	152	1795	1495	322	1739	1176	600
Grp Volume(v), veh/h	197	71	23	57	0	61	77	0	254	26	0	669
Grp Sat Flow(s),veh/h/ln	1795	1870	1448	1739	0	1849	1795	0	1817	1739	0	1776
Q Serve(g_s), s	5.9	2.1	0.8	1.9	0.0	2.0	1.5	0.0	5.9	0.5	0.0	22.7
Cycle Q Clear(g_c), s	5.9	2.1	0.8	1.9	0.0	2.0	1.5	0.0	5.9	0.5	0.0	22.7
Prop In Lane	1.00		1.00	1.00		0.08	1.00		0.18	1.00		0.34
Lane Grp Cap(c), veh/h	448	394	305	328	0	245	260	0	828	551	0	768
V/C Ratio(X)	0.44	0.18	0.08	0.17	0.00	0.25	0.30	0.00	0.31	0.05	0.00	0.87
Avail Cap(c_a), veh/h	506	737	570	367	0	567	289	0	1034	619	0	1011
HCM Platoon Ratio	1.00	1.00	1.00	1.00	1.00	1.00	1.00	1.00	1.00	1.00	1.00	1.00
Upstream Filter(I)	1.00	1.00	1.00	1.00	0.00	1.00	1.00	0.00	1.00	1.00	0.00	1.00
Uniform Delay (d), s/veh	19.4	21.5	21.0	23.5	0.0	25.8	13.7	0.0	11.4	10.1	0.0	17.1
Incr Delay (d2), s/veh	0.7	0.2	0.1	0.2	0.0	0.5	0.6	0.0	0.2	0.0	0.0	6.6
Initial Q Delay(d3),s/veh	0.0	0.0	0.0	0.0	0.0	0.0	0.0	0.0	0.0	0.0	0.0	0.0
%ile BackOfQ(50%),veh/ln	2.4	0.9	0.3	0.7	0.0	0.9	0.6	0.0	2.2	0.2	0.0	9.5
Unsig. Movement Delay, s/veh												
LnGrp Delay(d),s/veh	20.1	21.7	21.1	23.7	0.0	26.3	14.4	0.0	11.6	10.1	0.0	23.7
LnGrp LOS	C	C	C	C	A	C	B	A	B	B	A	C
Approach Vol, veh/h		291			118			331				695
Approach Delay, s/veh		20.6			25.1			12.3				23.2
Approach LOS		C			C			B				C
Timer - Assigned Phs	1	2	3	4	5	6	7	8				
Phs Duration (G+Y+Rc), s	7.5	33.2	12.3	13.3	6.0	34.7	7.1	18.4				
Change Period (Y+Rc), s	4.5	4.5	4.5	4.5	4.5	4.5	4.5	4.5				
Max Green Setting (Gmax), s	4.1	37.7	9.9	20.3	4.1	37.7	4.1	26.1				
Max Q Clear Time (g_c+I1), s	3.5	24.7	7.9	4.0	2.5	7.9	3.9	4.1				
Green Ext Time (p_c), s	0.0	4.0	0.1	0.2	0.0	1.6	0.0	0.4				
Intersection Summary												
HCM 6th Ctrl Delay			20.3									
HCM 6th LOS			C									

Intersection												
Int Delay, s/veh	2.1											
Movement	EBL	EBT	EBR	WBL	WBT	WBR	NBL	NBT	NBR	SBL	SBT	SBR
Lane Configurations		↕			↕			↕			↕	
Traffic Vol, veh/h	61	362	44	5	355	15	21	0	8	10	0	39
Future Vol, veh/h	61	362	44	5	355	15	21	0	8	10	0	39
Conflicting Peds, #/hr	0	0	0	0	0	0	2	0	0	0	0	2
Sign Control	Free	Free	Free	Free	Free	Free	Stop	Stop	Stop	Stop	Stop	Stop
RT Channelized	-	-	None	-	-	None	-	-	None	-	-	None
Storage Length	-	-	-	-	-	-	-	-	-	-	-	-
Veh in Median Storage, #	-	0	-	-	0	-	-	0	-	-	0	-
Grade, %	-	0	-	-	0	-	-	0	-	-	0	-
Peak Hour Factor	90	90	90	90	90	90	90	90	90	90	90	90
Heavy Vehicles, %	15	1	0	0	3	25	5	0	0	0	0	25
Mvmt Flow	68	402	49	6	394	17	23	0	9	11	0	43

Major/Minor	Major1			Major2			Minor1			Minor2		
Conflicting Flow All	411	0	0	451	0	0	1001	986	427	982	1002	405
Stage 1	-	-	-	-	-	-	563	563	-	415	415	-
Stage 2	-	-	-	-	-	-	438	423	-	567	587	-
Critical Hdwy	4.25	-	-	4.1	-	-	7.15	6.5	6.2	7.1	6.5	6.45
Critical Hdwy Stg 1	-	-	-	-	-	-	6.15	5.5	-	6.1	5.5	-
Critical Hdwy Stg 2	-	-	-	-	-	-	6.15	5.5	-	6.1	5.5	-
Follow-up Hdwy	2.335	-	-	2.2	-	-	3.545	4	3.3	3.5	4	3.525
Pot Cap-1 Maneuver	1081	-	-	1120	-	-	219	250	632	230	244	599
Stage 1	-	-	-	-	-	-	506	512	-	619	596	-
Stage 2	-	-	-	-	-	-	592	591	-	512	500	-
Platoon blocked, %		-	-		-	-						
Mov Cap-1 Maneuver	1081	-	-	1120	-	-	189	227	632	211	222	598
Mov Cap-2 Maneuver	-	-	-	-	-	-	189	227	-	211	222	-
Stage 1	-	-	-	-	-	-	463	468	-	566	592	-
Stage 2	-	-	-	-	-	-	544	587	-	462	458	-

Approach	EB			WB			NB			SB		
HCM Control Delay, s	1.1			0.1			22.8			14.5		
HCM LOS							C			B		

Minor Lane/Major Mvmt	NBLn1	EBL	EBT	EBR	WBL	WBT	WBR	SBLn1
Capacity (veh/h)	234	1081	-	-	1120	-	-	435
HCM Lane V/C Ratio	0.138	0.063	-	-	0.005	-	-	0.125
HCM Control Delay (s)	22.8	8.6	0	-	8.2	0	-	14.5
HCM Lane LOS	C	A	A	-	A	A	-	B
HCM 95th %tile Q(veh)	0.5	0.2	-	-	0	-	-	0.4

Intersection	
Intersection Delay, s/veh	28.6
Intersection LOS	D

Movement	EBL	EBT	EBR	WBL	WBT	WBR	NBL	NBT	NBR	SBL	SBT	SBR
Lane Configurations	↶	↷		↶	↷		↶	↷		↶	↷	
Traffic Vol, veh/h	57	292	47	68	286	65	30	91	78	113	154	74
Future Vol, veh/h	57	292	47	68	286	65	30	91	78	113	154	74
Peak Hour Factor	0.90	0.90	0.90	0.90	0.90	0.90	0.90	0.90	0.90	0.90	0.90	0.90
Heavy Vehicles, %	0	2	2	2	3	5	0	3	0	0	1	0
Mvmt Flow	63	324	52	76	318	72	33	101	87	126	171	82
Number of Lanes	1	1	0	1	1	0	1	1	0	1	1	0

Approach	EB	WB	NB	SB
Opposing Approach	WB	EB	SB	NB
Opposing Lanes	2	2	2	2
Conflicting Approach Left	SB	NB	EB	WB
Conflicting Lanes Left	2	2	2	2
Conflicting Approach Right	NB	SB	WB	EB
Conflicting Lanes Right	2	2	2	2
HCM Control Delay	34.4	36.3	17.1	19.3
HCM LOS	D	E	C	C

Lane	NBLn1	NBLn2	EBLn1	EBLn2	WBLn1	WBLn2	SBLn1	SBLn2
Vol Left, %	100%	0%	100%	0%	100%	0%	100%	0%
Vol Thru, %	0%	54%	0%	86%	0%	81%	0%	68%
Vol Right, %	0%	46%	0%	14%	0%	19%	0%	32%
Sign Control	Stop	Stop	Stop	Stop	Stop	Stop	Stop	Stop
Traffic Vol by Lane	30	169	57	339	68	351	113	228
LT Vol	30	0	57	0	68	0	113	0
Through Vol	0	91	0	292	0	286	0	154
RT Vol	0	78	0	47	0	65	0	74
Lane Flow Rate	33	188	63	377	76	390	126	253
Geometry Grp	7	7	7	7	7	7	7	7
Degree of Util (X)	0.086	0.442	0.149	0.824	0.177	0.847	0.309	0.571
Departure Headway (Hd)	9.277	8.473	8.458	7.877	8.449	7.817	8.851	8.115
Convergence, Y/N	Yes	Yes	Yes	Yes	Yes	Yes	Yes	Yes
Cap	386	424	424	460	425	464	407	446
Service Time	7.032	6.227	6.205	5.623	6.195	5.562	6.6	5.863
HCM Lane V/C Ratio	0.085	0.443	0.149	0.82	0.179	0.841	0.31	0.567
HCM Control Delay	12.9	17.8	12.7	38.1	13	40.8	15.5	21.2
HCM Lane LOS	B	C	B	E	B	E	C	C
HCM 95th-tile Q	0.3	2.2	0.5	7.9	0.6	8.5	1.3	3.5

HCM 6th Signalized Intersection Summary
6: Parkway Ave & Boeckman Rd

Frog Pond Oaks
Existing PM + Stage II



Movement	EBL	EBT	EBR	WBL	WBT	WBR	NBL	NBT	NBR	SBL	SBT	SBR
Lane Configurations												
Traffic Volume (veh/h)	117	263	181	81	283	31	141	171	68	42	329	212
Future Volume (veh/h)	117	263	181	81	283	31	141	171	68	42	329	212
Initial Q (Qb), veh	0	0	0	0	0	0	0	0	0	0	0	0
Ped-Bike Adj(A_pbT)	1.00		1.00	1.00		1.00	1.00		1.00	1.00		1.00
Parking Bus, Adj	1.00	1.00	1.00	1.00	1.00	1.00	1.00	1.00	1.00	1.00	1.00	1.00
Work Zone On Approach		No			No			No			No	
Adj Sat Flow, veh/h/ln	1870	1870	1870	1856	1841	1781	1885	1870	1900	1856	1885	1885
Adj Flow Rate, veh/h	123	277	163	85	298	29	148	180	56	44	346	196
Peak Hour Factor	0.95	0.95	0.95	0.95	0.95	0.95	0.95	0.95	0.95	0.95	0.95	0.95
Percent Heavy Veh, %	2	2	2	3	4	8	1	2	0	3	1	1
Cap, veh/h	337	315	185	235	439	43	291	538	167	500	396	224
Arrive On Green	0.07	0.29	0.29	0.05	0.27	0.27	0.08	0.39	0.39	0.03	0.35	0.35
Sat Flow, veh/h	1781	1102	649	1767	1650	161	1795	1368	425	1767	1129	640
Grp Volume(v), veh/h	123	0	440	85	0	327	148	0	236	44	0	542
Grp Sat Flow(s),veh/h/ln	1781	0	1751	1767	0	1811	1795	0	1793	1767	0	1769
Q Serve(g_s), s	3.5	0.0	17.2	2.5	0.0	11.6	3.6	0.0	6.6	1.1	0.0	20.6
Cycle Q Clear(g_c), s	3.5	0.0	17.2	2.5	0.0	11.6	3.6	0.0	6.6	1.1	0.0	20.6
Prop In Lane	1.00		0.37	1.00		0.09	1.00		0.24	1.00		0.36
Lane Grp Cap(c), veh/h	337	0	500	235	0	482	291	0	705	500	0	621
V/C Ratio(X)	0.37	0.00	0.88	0.36	0.00	0.68	0.51	0.00	0.33	0.09	0.00	0.87
Avail Cap(c_a), veh/h	408	0	598	341	0	618	356	0	812	639	0	801
HCM Platoon Ratio	1.00	1.00	1.00	1.00	1.00	1.00	1.00	1.00	1.00	1.00	1.00	1.00
Upstream Filter(I)	1.00	0.00	1.00	1.00	0.00	1.00	1.00	0.00	1.00	1.00	0.00	1.00
Uniform Delay (d), s/veh	18.0	0.0	24.5	19.5	0.0	23.6	16.2	0.0	15.2	14.1	0.0	21.8
Incr Delay (d2), s/veh	0.7	0.0	12.5	0.9	0.0	2.0	1.4	0.0	0.3	0.1	0.0	8.6
Initial Q Delay(d3),s/veh	0.0	0.0	0.0	0.0	0.0	0.0	0.0	0.0	0.0	0.0	0.0	0.0
%ile BackOfQ(50%),veh/ln	4	0.0	8.4	1.0	0.0	5.0	1.4	0.0	2.6	0.4	0.0	9.3
Unsig. Movement Delay, s/veh												
LnGrp Delay(d),s/veh	18.7	0.0	37.0	20.4	0.0	25.6	17.5	0.0	15.5	14.2	0.0	30.4
LnGrp LOS	B	A	D	C	A	C	B	A	B	B	A	C
Approach Vol, veh/h		563			412			384			586	
Approach Delay, s/veh		33.0			24.6			16.3			29.2	
Approach LOS		C			C			B			C	
Timer - Assigned Phs	1	2	3	4	5	6	7	8				
Phs Duration (G+Y+Rc), s	9.4	29.7	7.7	25.0	6.3	32.7	9.1	23.6				
Change Period (Y+Rc), s	4.0	4.5	4.0	4.5	4.0	4.5	4.0	4.5				
Max Green Setting (Gmax), s	30.0	32.5	8.0	24.5	8.0	32.5	8.0	24.5				
Max Q Clear Time (g_c+1/6), s	15.6	22.6	4.5	19.2	3.1	8.6	5.5	13.6				
Green Ext Time (p_c), s	0.1	2.6	0.0	1.3	0.0	1.4	0.1	1.4				
Intersection Summary												
HCM 6th Ctrl Delay												26.7
HCM 6th LOS												C

Synchro ID	Control Type	Intersection	Control Type	LOS	Delay	V/C Ratio
	3 Signal	Wilsonville Rd/Stafford Rd & Boeckman R	Signal	C	20.3	0.70
	6 Signal	Parkway Ave & Boeckman Rd	Signal	C	26.7	0.85

F. HCM REPORTS – EXISTING + PROJECT + STAGE II

Intersection						
Int Delay, s/veh	1.2					
Movement	EBL	EBR	NBL	NBT	SBT	SBR
Lane Configurations	T		T		T	
Traffic Vol, veh/h	34	15	18	422	713	58
Future Vol, veh/h	34	15	18	422	713	58
Conflicting Peds, #/hr	0	0	2	0	0	2
Sign Control	Stop	Stop	Free	Free	Free	Free
RT Channelized	-	None	-	None	-	None
Storage Length	0	-	-	-	-	-
Veh in Median Storage, #	0	-	-	0	0	-
Grade, %	0	-	-	0	0	-
Peak Hour Factor	92	92	92	92	92	92
Heavy Vehicles, %	0	0	0	0	2	50
Mvmt Flow	37	16	20	459	775	63

Major/Minor	Minor2	Major1	Major2			
Conflicting Flow All	1308	809	840	0	-	0
Stage 1	809	-	-	-	-	-
Stage 2	499	-	-	-	-	-
Critical Hdwy	6.4	6.2	4.1	-	-	-
Critical Hdwy Stg 1	5.4	-	-	-	-	-
Critical Hdwy Stg 2	5.4	-	-	-	-	-
Follow-up Hdwy	3.5	3.3	2.2	-	-	-
Pot Cap-1 Maneuver	178	384	804	-	-	-
Stage 1	441	-	-	-	-	-
Stage 2	614	-	-	-	-	-
Platoon blocked, %				-	-	-
Mov Cap-1 Maneuver	171	383	803	-	-	-
Mov Cap-2 Maneuver	171	-	-	-	-	-
Stage 1	426	-	-	-	-	-
Stage 2	613	-	-	-	-	-

Approach	EB	NB	SB
HCM Control Delay, s	28.5	0.4	0
HCM LOS	D		

Minor Lane/Major Mvmt	NBL	NBT	EBLn1	SBT	SBR
Capacity (veh/h)	803	-	206	-	-
HCM Lane V/C Ratio	0.024	-	0.259	-	-
HCM Control Delay (s)	9.6	0	28.5	-	-
HCM Lane LOS	A	A	D	-	-
HCM 95th %tile Q(veh)	0.1	-	1	-	-

Intersection						
Int Delay, s/veh	0.8					
Movement	EBL	EBR	NBL	NBT	SBT	SBR
Lane Configurations						
Traffic Vol, veh/h	22	11	11	418	700	28
Future Vol, veh/h	22	11	11	418	700	28
Conflicting Peds, #/hr	0	0	2	0	0	2
Sign Control	Stop	Stop	Free	Free	Free	Free
RT Channelized	-	None	-	None	-	None
Storage Length	0	-	-	-	-	-
Veh in Median Storage, #	0	-	-	0	0	-
Grade, %	0	-	-	0	0	-
Peak Hour Factor	92	92	92	92	92	92
Heavy Vehicles, %	0	0	25	0	2	0
Mvmt Flow	24	12	12	454	761	30

Major/Minor	Minor2	Major1		Major2	
Conflicting Flow All	1256	778	793	0	0
Stage 1	778	-	-	-	-
Stage 2	478	-	-	-	-
Critical Hdwy	6.4	6.2	4.35	-	-
Critical Hdwy Stg 1	5.4	-	-	-	-
Critical Hdwy Stg 2	5.4	-	-	-	-
Follow-up Hdwy	3.5	3.3	2.425	-	-
Pot Cap-1 Maneuver	191	400	735	-	-
Stage 1	456	-	-	-	-
Stage 2	628	-	-	-	-
Platoon blocked, %				-	-
Mov Cap-1 Maneuver	186	399	734	-	-
Mov Cap-2 Maneuver	186	-	-	-	-
Stage 1	445	-	-	-	-
Stage 2	627	-	-	-	-

Approach	EB	NB	SB
HCM Control Delay, s	23.9	0.3	0
HCM LOS	C		

Minor Lane/Major Mvmt	NBL	NBT	EBLn1	SBT	SBR
Capacity (veh/h)	734	-	226	-	-
HCM Lane V/C Ratio	0.016	-	0.159	-	-
HCM Control Delay (s)	10	0	23.9	-	-
HCM Lane LOS	A	A	C	-	-
HCM 95th %tile Q(veh)	0.1	-	0.6	-	-

HCM 6th Signalized Intersection Summary
 3: Wilsonville Rd/Stafford Rd & Boeckman Rd/Advance Rd

Frog Pond Oaks
 Existing PM + Project + Stage II



Movement	EBL	EBT	EBR	WBL	WBT	WBR	NBL	NBT	NBR	SBL	SBT	SBR
Lane Configurations												
Traffic Volume (veh/h)	195	70	116	56	55	25	77	209	53	27	440	244
Future Volume (veh/h)	195	70	116	56	55	25	77	209	53	27	440	244
Initial Q (Qb), veh	0	0	0	0	0	0	0	0	0	0	0	0
Ped-Bike Adj(A_pbT)	0.93		0.91	0.90		0.88	1.00		0.97	1.00		1.00
Parking Bus, Adj	1.00	1.00	1.00	1.00	1.00	1.00	1.00	1.00	1.00	1.00	1.00	1.00
Work Zone On Approach		No			No			No			No	
Adj Sat Flow, veh/h/ln	1885	1870	1885	1826	1900	1900	1885	1885	1870	1826	1885	1856
Adj Flow Rate, veh/h	197	71	24	57	56	5	78	211	45	27	444	226
Peak Hour Factor	0.99	0.99	0.99	0.99	0.99	0.99	0.99	0.99	0.99	0.99	0.99	0.99
Percent Heavy Veh, %	1	2	1	5	0	0	1	1	2	5	1	3
Cap, veh/h	448	394	305	327	225	20	260	682	146	551	510	259
Arrive On Green	0.12	0.21	0.21	0.04	0.13	0.13	0.05	0.46	0.46	0.02	0.43	0.43
Sat Flow, veh/h	1795	1870	1448	1739	1697	152	1795	1498	320	1739	1177	599
Grp Volume(v), veh/h	197	71	24	57	0	61	78	0	256	27	0	670
Grp Sat Flow(s),veh/h/ln	1795	1870	1448	1739	0	1849	1795	0	1818	1739	0	1776
Q Serve(g_s), s	5.9	2.1	0.9	1.9	0.0	2.0	1.6	0.0	5.9	0.6	0.0	22.8
Cycle Q Clear(g_c), s	5.9	2.1	0.9	1.9	0.0	2.0	1.6	0.0	5.9	0.6	0.0	22.8
Prop In Lane	1.00		1.00	1.00		0.08	1.00		0.18	1.00		0.34
Lane Grp Cap(c), veh/h	448	394	305	327	0	245	260	0	828	551	0	769
V/C Ratio(X)	0.44	0.18	0.08	0.17	0.00	0.25	0.30	0.00	0.31	0.05	0.00	0.87
Avail Cap(c_a), veh/h	505	736	569	367	0	566	289	0	1033	617	0	1009
HCM Platoon Ratio	1.00	1.00	1.00	1.00	1.00	1.00	1.00	1.00	1.00	1.00	1.00	1.00
Upstream Filter(I)	1.00	1.00	1.00	1.00	0.00	1.00	1.00	0.00	1.00	1.00	0.00	1.00
Uniform Delay (d), s/veh	19.5	21.5	21.0	23.5	0.0	25.8	13.8	0.0	11.4	10.1	0.0	17.1
Incr Delay (d2), s/veh	0.7	0.2	0.1	0.3	0.0	0.5	0.6	0.0	0.2	0.0	0.0	6.7
Initial Q Delay(d3),s/veh	0.0	0.0	0.0	0.0	0.0	0.0	0.0	0.0	0.0	0.0	0.0	0.0
%ile BackOfQ(50%),veh/ln	2.4	0.9	0.3	0.8	0.0	0.9	0.6	0.0	2.2	0.2	0.0	9.6
Unsig. Movement Delay, s/veh												
LnGrp Delay(d),s/veh	20.2	21.7	21.1	23.8	0.0	26.4	14.4	0.0	11.7	10.1	0.0	23.8
LnGrp LOS	C	C	C	C	A	C	B	A	B	B	A	C
Approach Vol, veh/h		292			118			334				697
Approach Delay, s/veh		20.6			25.1			12.3				23.3
Approach LOS		C			C			B				C
Timer - Assigned Phs	1	2	3	4	5	6	7	8				
Phs Duration (G+Y+Rc), s	7.5	33.2	12.3	13.3	6.1	34.7	7.1	18.5				
Change Period (Y+Rc), s	4.5	4.5	4.5	4.5	4.5	4.5	4.5	4.5				
Max Green Setting (Gmax), s	4.1	37.7	9.9	20.3	4.1	37.7	4.1	26.1				
Max Q Clear Time (g_c+I1), s	3.6	24.8	7.9	4.0	2.6	7.9	3.9	4.1				
Green Ext Time (p_c), s	0.0	3.9	0.1	0.2	0.0	1.6	0.0	0.4				
Intersection Summary												
HCM 6th Ctrl Delay			20.4									
HCM 6th LOS			C									

Intersection												
Int Delay, s/veh	2.3											
Movement	EBL	EBT	EBR	WBL	WBT	WBR	NBL	NBT	NBR	SBL	SBT	SBR
Lane Configurations		↕			↕			↕			↕	
Traffic Vol, veh/h	70	362	44	5	355	16	21	0	8	11	0	44
Future Vol, veh/h	70	362	44	5	355	16	21	0	8	11	0	44
Conflicting Peds, #/hr	0	0	0	0	0	0	2	0	0	0	0	2
Sign Control	Free	Free	Free	Free	Free	Free	Stop	Stop	Stop	Stop	Stop	Stop
RT Channelized	-	-	None	-	-	None	-	-	None	-	-	None
Storage Length	-	-	-	-	-	-	-	-	-	-	-	-
Veh in Median Storage, #	-	0	-	-	0	-	-	0	-	-	0	-
Grade, %	-	0	-	-	0	-	-	0	-	-	0	-
Peak Hour Factor	90	90	90	90	90	90	90	90	90	90	90	90
Heavy Vehicles, %	15	1	0	0	3	25	5	0	0	0	0	25
Mvmt Flow	78	402	49	6	394	18	23	0	9	12	0	49

Major/Minor	Major1			Major2			Minor1			Minor2		
Conflicting Flow All	412	0	0	451	0	0	1025	1007	427	1002	1022	405
Stage 1	-	-	-	-	-	-	583	583	-	415	415	-
Stage 2	-	-	-	-	-	-	442	424	-	587	607	-
Critical Hdwy	4.25	-	-	4.1	-	-	7.15	6.5	6.2	7.1	6.5	6.45
Critical Hdwy Stg 1	-	-	-	-	-	-	6.15	5.5	-	6.1	5.5	-
Critical Hdwy Stg 2	-	-	-	-	-	-	6.15	5.5	-	6.1	5.5	-
Follow-up Hdwy	2.335	-	-	2.2	-	-	3.545	4	3.3	3.5	4	3.525
Pot Cap-1 Maneuver	1080	-	-	1120	-	-	211	243	632	223	238	599
Stage 1	-	-	-	-	-	-	493	502	-	619	596	-
Stage 2	-	-	-	-	-	-	589	590	-	499	489	-
Platoon blocked, %		-	-		-	-						
Mov Cap-1 Maneuver	1080	-	-	1120	-	-	178	218	632	202	213	598
Mov Cap-2 Maneuver	-	-	-	-	-	-	178	218	-	202	213	-
Stage 1	-	-	-	-	-	-	445	453	-	559	592	-
Stage 2	-	-	-	-	-	-	536	586	-	444	442	-

Approach	EB			WB			NB			SB		
HCM Control Delay, s	1.3			0.1			24			14.8		
HCM LOS							C			B		

Minor Lane/Major Mvmt	NBLn1	EBL	EBT	EBR	WBL	WBT	WBR	SBLn1
Capacity (veh/h)	222	1080	-	-	1120	-	-	430
HCM Lane V/C Ratio	0.145	0.072	-	-	0.005	-	-	0.142
HCM Control Delay (s)	24	8.6	0	-	8.2	0	-	14.8
HCM Lane LOS	C	A	A	-	A	A	-	B
HCM 95th %tile Q(veh)	0.5	0.2	-	-	0	-	-	0.5

Intersection	
Intersection Delay, s/veh	30.2
Intersection LOS	D

Movement	EBL	EBT	EBR	WBL	WBT	WBR	NBL	NBT	NBR	SBL	SBT	SBR
Lane Configurations	↶	↷		↶	↷		↶	↷		↶	↷	
Traffic Vol, veh/h	57	299	47	69	289	66	30	91	79	114	154	74
Future Vol, veh/h	57	299	47	69	289	66	30	91	79	114	154	74
Peak Hour Factor	0.90	0.90	0.90	0.90	0.90	0.90	0.90	0.90	0.90	0.90	0.90	0.90
Heavy Vehicles, %	0	2	2	2	3	5	0	3	0	0	1	0
Mvmt Flow	63	332	52	77	321	73	33	101	88	127	171	82
Number of Lanes	1	1	0	1	1	0	1	1	0	1	1	0

Approach	EB	WB	NB	SB
Opposing Approach	WB	EB	SB	NB
Opposing Lanes	2	2	2	2
Conflicting Approach Left	SB	NB	EB	WB
Conflicting Lanes Left	2	2	2	2
Conflicting Approach Right	NB	SB	WB	EB
Conflicting Lanes Right	2	2	2	2
HCM Control Delay	37.1	38.2	17.3	19.6
HCM LOS	E	E	C	C

Lane	NBLn1	NBLn2	EBLn1	EBLn2	WBLn1	WBLn2	SBLn1	SBLn2
Vol Left, %	100%	0%	100%	0%	100%	0%	100%	0%
Vol Thru, %	0%	54%	0%	86%	0%	81%	0%	68%
Vol Right, %	0%	46%	0%	14%	0%	19%	0%	32%
Sign Control	Stop	Stop	Stop	Stop	Stop	Stop	Stop	Stop
Traffic Vol by Lane	30	170	57	346	69	355	114	228
LT Vol	30	0	57	0	69	0	114	0
Through Vol	0	91	0	299	0	289	0	154
RT Vol	0	79	0	47	0	66	0	74
Lane Flow Rate	33	189	63	384	77	394	127	253
Geometry Grp	7	7	7	7	7	7	7	7
Degree of Util (X)	0.087	0.448	0.15	0.846	0.181	0.862	0.314	0.576
Departure Headway (Hd)	9.351	8.544	8.505	7.925	8.502	7.869	8.919	8.182
Convergence, Y/N	Yes	Yes	Yes	Yes	Yes	Yes	Yes	Yes
Cap	383	421	422	457	422	462	403	441
Service Time	7.107	6.299	6.253	5.673	6.251	5.617	6.67	5.933
HCM Lane V/C Ratio	0.086	0.449	0.149	0.84	0.182	0.853	0.315	0.574
HCM Control Delay	13	18.1	12.8	41.1	13.1	43.1	15.7	21.5
HCM Lane LOS	B	C	B	E	B	E	C	C
HCM 95th-tile Q	0.3	2.3	0.5	8.4	0.7	8.8	1.3	3.5

HCM 6th Signalized Intersection Summary
6: Parkway Ave & Boeckman Rd

Frog Pond Oaks
Existing PM + Project + Stage II



Movement	EBL	EBT	EBR	WBL	WBT	WBR	NBL	NBT	NBR	SBL	SBT	SBR
Lane Configurations												
Traffic Volume (veh/h)	117	268	181	82	284	32	141	171	69	43	329	212
Future Volume (veh/h)	117	268	181	82	284	32	141	171	69	43	329	212
Initial Q (Qb), veh	0	0	0	0	0	0	0	0	0	0	0	0
Ped-Bike Adj(A_pbT)	1.00		1.00	1.00		1.00	1.00		1.00	1.00		1.00
Parking Bus, Adj	1.00	1.00	1.00	1.00	1.00	1.00	1.00	1.00	1.00	1.00	1.00	1.00
Work Zone On Approach		No			No			No			No	
Adj Sat Flow, veh/h/ln	1870	1870	1870	1856	1841	1781	1885	1870	1900	1856	1885	1885
Adj Flow Rate, veh/h	123	282	163	86	299	30	148	180	57	45	346	196
Peak Hour Factor	0.95	0.95	0.95	0.95	0.95	0.95	0.95	0.95	0.95	0.95	0.95	0.95
Percent Heavy Veh, %	2	2	2	3	4	8	1	2	0	3	1	1
Cap, veh/h	340	322	186	236	445	45	287	532	168	495	394	223
Arrive On Green	0.07	0.29	0.29	0.05	0.27	0.27	0.08	0.39	0.39	0.03	0.35	0.35
Sat Flow, veh/h	1781	1110	642	1767	1645	165	1795	1361	431	1767	1129	640
Grp Volume(v), veh/h	123	0	445	86	0	329	148	0	237	45	0	542
Grp Sat Flow(s),veh/h/ln	1781	0	1752	1767	0	1810	1795	0	1792	1767	0	1769
Q Serve(g_s), s	3.5	0.0	17.5	2.5	0.0	11.7	3.7	0.0	6.7	1.2	0.0	20.8
Cycle Q Clear(g_c), s	3.5	0.0	17.5	2.5	0.0	11.7	3.7	0.0	6.7	1.2	0.0	20.8
Prop In Lane	1.00		0.37	1.00		0.09	1.00		0.24	1.00		0.36
Lane Grp Cap(c), veh/h	340	0	507	236	0	490	287	0	700	495	0	616
V/C Ratio(X)	0.36	0.00	0.88	0.36	0.00	0.67	0.52	0.00	0.34	0.09	0.00	0.88
Avail Cap(c_a), veh/h	410	0	618	340	0	638	351	0	780	632	0	770
HCM Platoon Ratio	1.00	1.00	1.00	1.00	1.00	1.00	1.00	1.00	1.00	1.00	1.00	1.00
Upstream Filter(I)	1.00	0.00	1.00	1.00	0.00	1.00	1.00	0.00	1.00	1.00	0.00	1.00
Uniform Delay (d), s/veh	17.9	0.0	24.5	19.4	0.0	23.5	16.4	0.0	15.5	14.3	0.0	22.1
Incr Delay (d2), s/veh	0.6	0.0	11.7	0.9	0.0	1.8	1.4	0.0	0.3	0.1	0.0	9.7
Initial Q Delay(d3),s/veh	0.0	0.0	0.0	0.0	0.0	0.0	0.0	0.0	0.0	0.0	0.0	0.0
%ile BackOfQ(50%),veh/ln	1.4	0.0	8.4	1.0	0.0	5.0	1.5	0.0	2.6	0.4	0.0	9.6
Unsig. Movement Delay, s/veh												
LnGrp Delay(d),s/veh	18.6	0.0	36.2	20.4	0.0	25.3	17.9	0.0	15.8	14.4	0.0	31.8
LnGrp LOS	B	A	D	C	A	C	B	A	B	B	A	C
Approach Vol, veh/h		568			415			385			587	
Approach Delay, s/veh		32.4			24.3			16.6			30.5	
Approach LOS		C			C			B			C	
Timer - Assigned Phs	1	2	3	4	5	6	7	8				
Phs Duration (G+Y+Rc), s	9.4	29.7	7.7	25.4	6.4	32.8	9.1	24.1				
Change Period (Y+Rc), s	4.0	4.5	4.0	4.5	4.0	4.5	4.0	4.5				
Max Green Setting (Gmax), s	30.0	31.5	8.0	25.5	8.0	31.5	8.0	25.5				
Max Q Clear Time (g_c+1/3), s	15.0	22.8	4.5	19.5	3.2	8.7	5.5	13.7				
Green Ext Time (p_c), s	0.1	2.4	0.0	1.5	0.0	1.4	0.1	1.5				
Intersection Summary												
HCM 6th Ctrl Delay												27.0
HCM 6th LOS												C

Synchro ID	Control Type	Intersection	Control Type	LOS	Delay	V/C Ratio
	3 Signal	Wilsonville Rd/Stafford Rd & Boeckman R	Signal	C	20.4	0.70
	6 Signal	Parkway Ave & Boeckman Rd	Signal	C	27.0	0.85

G. SITE PLAN



STAMP
WEST HILLS
LAND DEVELOPMENT
CONSULTANT

FROG POND OAKS
41 DETACHED SINGLE FAMILY LOTS
CITY OF WILSONVILLE, OREGON

PRELIMINARY SITE PLAN

TITLE

#	DATE	DESCRIPTION

REVISIONS

NAVD88	DATUM	
OTAK CAD		KJB
DRAWN BY		CHECKED BY
LAND USE SUBMITTAL		STATUS
TBD	DATE	
20141	PROJECT NUMBER	

P2.00

© 2021 OTAK, INC.
If this drawing is not 22" x 34", it has been reduced/enlarged. Scale accordingly.

LEGEND

- PROPERTY LINE
- CENTER LINE
- LOT LINE
- LOT SETBACK
- LOT NUMBER / NAME 16
- EASEMENT LINE
- STANDARD CURB
- SIDEWALK
- RETAINING WALL
- INTERSECTION SIGHT DISTANCE [x]
x=DESIGN SPEED(MPH)x10/MPH
- TYPICAL STREET CROSS SECTION (SEE SHEET P2.10)
- PUBLIC RAIN GARDEN
- DRIVEWAY
- CURB RAMP

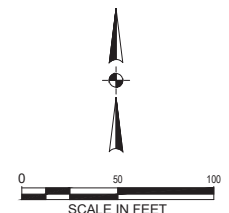
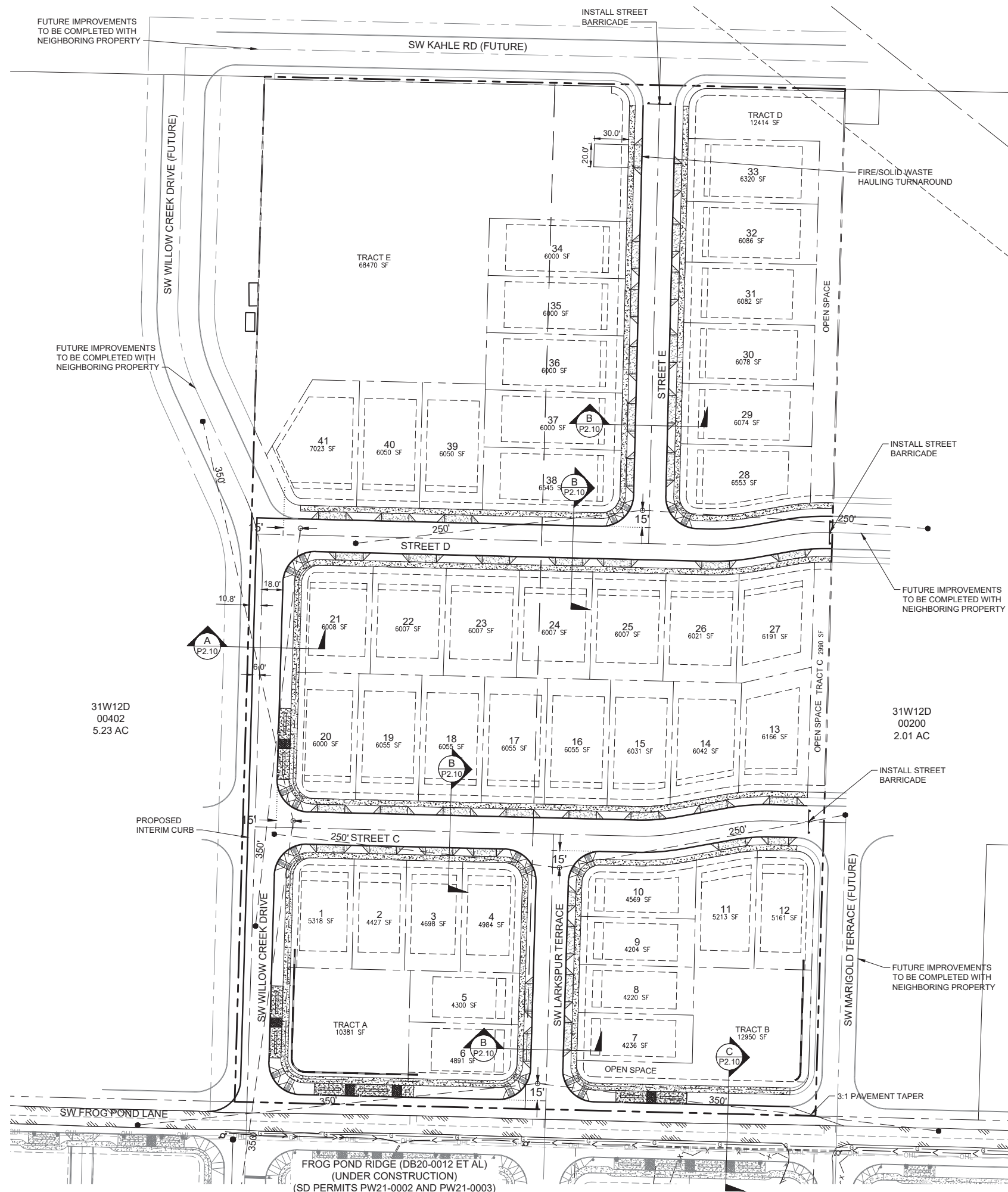
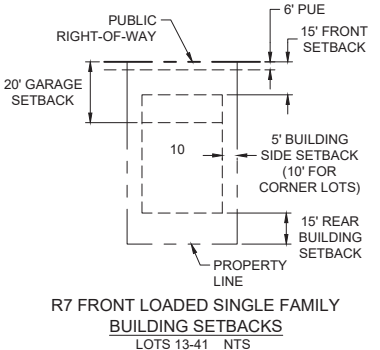
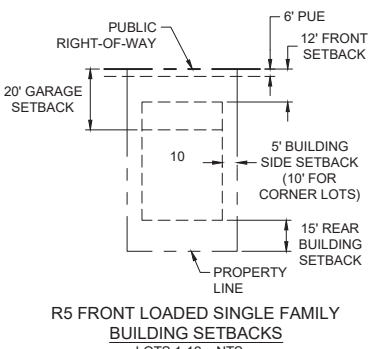

Plotted: Oct 28, 2021 - 9:47am - ush, Mathiasen - L:\Projects\2010020141\1\ADD\CAD\Draw\Print\Print - Otak\20141P200.dwg - Layout Name: P2.00

Appendix D

Frog Pond Oaks Significant Resource Overlay Zone (SROZ) Map Verification dated
October 2021 by AKS Engineering & Forestry, LLC



Frog Pond Oaks Significant Resource Overlay Zone (SROZ) Map Verification

Date: October 2021

Prepared for: West Hills Land Development
3330 NW Yeon, Suite 200
Portland, OR 97210

Prepared by: AKS Engineering & Forestry, LLC
Sonya Templeton, Natural Resource Specialist
Stacey Reed, PWS, Senior Wetland Scientist
503-563-6151 | staceyr@aks-eng.com

Site Information: Tax Lots 401 and 402
Clackamas County Assessor's Map 3 1W 12D
Wilsonville, Clackamas County, Oregon

AKS Job Number: 7005



12965 SW Herman Road, Suite 100
Tualatin, OR 97062
(503) 563-6151

Table of Contents

Introduction.....	1
Background Mapping and Site Information	1
Wetlands and Waters Mapping	2
Wetland Delineation.....	2
Wetlands	2
Adding Wetlands to SROZ	3
Report Preparer and Qualifications.....	4
Literature Cited and Referenced	5

Figures

- Figure 1:** USGS Vicinity Map
- Figure 2:** Tax Map
- Figure 3:** NRCS Soils Map
- Figure 4:** National Wetlands Inventory (NWI) Map
- Figure 5:** PHS Frog Pond UGB Area Planning Map
- Figure 6:** Natural Resources Existing Conditions Map

Appendices

- Appendix A:** Site Representative Photos
 - Appendix B:** OFWAM Assessment for Water Quality and Hydrologic Control Functions
-

Introduction

AKS Engineering & Forestry, LLC (AKS) was contracted by West Hills Land Development to prepare a Significant Resource Overlay Zone (SROZ) Map Verification for the Frog Pond Oaks residential development project located on Tax Lots 401 and 402 of Clackamas County Assessor's Map 3 1W 12D in Wilsonville, Clackamas County, Oregon (Figures 1 and 2). The project site is located within the Frog Pond West Neighborhood of the Frog Pond Plan Area and was added to the City of Wilsonville Urban Growth Boundary (UGB) in 2002.

The on-site boundary of one isolated, palustrine emergent wetland (referred to as PEM Wetland) was delineated within the study area. Wetland conditions do not extend off-site. The wetland is likely to be determined jurisdictional to the Oregon Department of State Lands (DSL). The wetland delineation report was submitted on September 14, 2021 and is currently under review by DSL per File WD#2021-0509. The on-site wetland is likely to be considered non-jurisdictional to the U.S. Army Corp of Engineers (USACE).

The PEM Wetland is not mapped as a Significant Natural Resource on the City of Wilsonville's (City) 2009 Significant Resource Overlay Zone (SROZ) Map and the PEM Wetland delineated on the project site does not meet any of the criteria listed under Section 4.139.10(.02) of the City of Wilsonville's (City) SROZ ordinance and is therefore not required to be added to the SROZ map as a significant wetland and do not require a vegetated corridor buffer.

The project will require complete fill to the on-site PEM Wetland for the construction of a single family residential subdivision. All work within the potentially jurisdictional wetland will require a removal-fill permit from DSL for removal and/or fill within the wetland exceeding 50 cubic yards.

This report documents the PEM Wetland delineated on the project site does not meet requirements listed under Section 4.139.10(.02)A-D and therefore should not be added to the SROZ maps.

Background Mapping and Site Information

The study area consists of an open field, with a home and detached buildings in the southern portion of the site adjacent to SW Frog Pond Road. The surrounding land use is residential. Topography in the study area is generally flat with a subtle southerly slope (less than 5 percent) towards SW Frog Pond Lane. A roadside ditch is present along the north side of SW Frog Pond Lane. The ditch continues off-site to the west. The ditch does not drain wetland and is not contiguous with wetland conditions.

The field is dominated by field meadow foxtail (*Alopecurus pratensis*, FAC), bentgrass (*Agrostis species*, FAC), and bluegrass (*Poa species*, FAC). Ponderosa pine (*Pinus ponderosa*, FAC) and Oregon white oak (*Quercus garryana*, FACU) trees are present in the northwestern portion of the study area.

According to the Natural Resources Conservation Service (NRCS) Clackamas County Area Soil Survey Map, the following soil units are mapped within the study area, (Figure 3):

- (Unit 1A) Aloha silt loam, 0 to 3 percent slopes; Non-hydric, with 3% hydric Huberly and 2% hydric Dayton inclusions in depressions.
- (Unit 91B) Woodburn silt loam, 3 to 85 percent slopes; Non-hydric, with 2% hydric Huberly inclusions in depression, 1% hydric Aquolls inclusions in floodplains, and 1% hydric Dayton inclusions in terraces.

Wetlands and Waters Mapping

Wilsonville DSL Approved Local Wetland and Riparian Inventory Maps: The project site is not within the City of Wilsonville's 1998 Local Wetland or Riparian Corridor Inventory map boundaries.

National Wetland Inventory Map: According to the US Fish and Wildlife Service (USFWS) National Wetland Inventory (NWI) map, no wetlands are mapped in the project area (Figure 4).

City of Wilsonville Significant Resource Overlay Zone (SROZ) Map: There are no Significant Natural Resources mapped within the project site according to the City's 2009 SROZ Map.

Frog Pond and Advance Road Urban Growth (UGB) Areas: According to Pacific Habitat Services (PHS) 2017 study for the Frog Pond and Advance Road UGB, three wetlands (identified as Wetlands 7A, 7B, and 7C) are mapped on project site (Figure 5). Our study determined one large polygon of wetland is present on the site.

Metro's UGMFP Title 3 Water Quality Resource and Title 13 Habitat Conservation Area Maps: According to Metro's mapping, no Title 3 or Title 13 resources are mapped on the site or immediately adjacent to the site.

Wetland Delineation

AKS delineated the boundary of one PEM wetland polygon on the project site on March 31, 2021 by Senior Wetland Scientist Stacey Reed, PWS, and Natural Resource Specialist Sonya Templeton. The boundary of the PEM wetland delineated on the project site is shown on Figure 6, Natural Resources Existing Conditions Map. Site Representative Photos are included in Appendix A. The wetland delineation report is currently under review at DSL per DSL File WD2021-0509. The Non-Jurisdictional Determination is currently under review by the USACE.

Wetlands

A palustrine emergent (PEM) wetland was delineated in the central portion of the study area. The wetland is isolated and does not have a surface water connection to other on-site wetlands or the roadside ditch. Wetland conditions do not extend off site. The wetland gently slopes to the south and receives hydrology from upslope runoff, a seasonally high groundwater table, and precipitation; therefore, the wetland belongs to the Slope hydrogeomorphic (HGM) subclassification.

Vegetation within the wetland was mainly dominated by meadow foxtail (FAC) with lesser amounts of a bluegrass species (FAC), a bentgrass species (FAC), and weedy upland forbs. Vegetation in the wetland is mowed regularly.

Soils in the wetland contained depleted matrix within the surface 12 inches, meeting hydric indicator A11 Depleted Below Dark Surface. A groundwater table and saturation were observed with 12 inches of the surface at all wetland plots during the March 2021 site visit.

The wetland boundary was delineated based on a slight change in landform, from a subtle concave depression in the wetland to a slightly higher elevation with convex landform in the upland. Several unrecorded test pits were dug to determine the wetland boundary. Lack of hydric soil indicators were heavily relied upon to determine the wetland boundary.

Adding Wetlands to SROZ

The PEM Wetland delineated on the project site is not mapped on the City's SROZ Map and does not meet any of the criteria listed under Section 4.139.10(.02)A-D of Wilsonville's SROZ ordinance:

Wilsonville Development Code

Section 4.139.10 Development Review Board (DRB) Process

(.02) Adding Wetlands. Except for water quality or storm water detention facilities, the City shall initiate amendments to the Significant Resource Overlay Zone maps to add wetlands when the City receives significant evidence that a wetland meets any one of the following criteria:

A. The wetland is fed by surface flows, sheet flows or precipitation, and has evidence of flooding during the growing season, and has 60 percent or greater vegetated cover, and is over one-half acre in size; or the wetland qualifies as having intact water quality function under the 1996 Oregon Freshwater Wetland Assessment Methodology; or

Response: Wetland on the site totals 0.80 acres in size. The wetland is primarily fed by subsurface lateral flow and is not fed by surface or sheet flows. The wetland does not flood during the growing season; it is only seasonally saturated. There was no evidence of inundation (no algal matting, unvegetated bare areas, or soil cracking) during our early springtime site visit (March 2021). Under the 1996 Oregon Freshwater Assessment Methodology (OFWAM), the wetland does not have an intact water quality control function (OFWAM worksheets included in Appendix B).

B. The wetland is in the Metro Title 3 Flood Management Area as corrected by the most current FEMA Flood Insurance Rate Maps, and has evidence of flooding during the growing season, and is five acres or more in size, and has a restricted outlet or no outlet; or the wetland qualifies as having intact hydrologic control function under the 1996 Oregon Freshwater Wetland Assessment Methodology; or

Response: Wetland delineated on the site is not mapped within a current Federal Emergency Management Agency (FEMA) Flood Management Area. According to OFWAM, the wetland does not have an intact hydrologic control function (see OFWAM worksheets included in Appendix B). There was no evidence of flooding during the growing season, the wetland area is less than 5 acres in size and lacks an outlet to waters.

C. The wetland or a portion of the wetland is within a horizontal distance of less than one - fourth mile from a water body which meets the Department of Environmental Quality definition of water quality limited water body in OAR Chapter 340, Division 41 (1996).

Response: Wetland on the project site is located greater than ¼-mile from an Oregon Department of Environmental Quality (DEQ) water-quality limited listed water body. The Willamette River is the closest water-quality limited water body, which is located over 1 mile from the project site.

D. Created or restored wetlands that meet the requirements of Section 4.139.10(.02) shall be added to the Significant Resource Overlay Zone. [Added by Ord. # 674 11/16/09]

Response: Wetland on the project site was not created or restored under requirements of Section 4.139.10 (.02) of City's SROZ ordinance.

Since the PEM Wetland delineated on the site does not meet any of the above criteria, it is locally non-significant and does not require Vegetated Corridor or Impact Area setbacks.

Report Preparer and Qualifications



Sonya Templeton
Natural Resource Specialist
Fieldwork, Report Preparation



Stacey Reed, PWS
Senior Wetland Scientist
Fieldwork, Report QA/QC

Stacey Reed is a certified Professional Wetland Scientist (PWS) with more than 20 years of experience delineating wetlands and waters, conducting wetland and stream function and value assessments and prepare natural resource assessments throughout Oregon.

Literature Cited and Referenced

- Adams, P.R. 2001. *Guidebook for Hydrogeomorphic (HGM)-based Assessment of Oregon Wetland and Riparian Sites: Statewide Classification and Profiles*. Salem (OR): Oregon Division of State Lands. Available at: http://www.oregon.gov/dsl/WW/Documents/hydro_guide_class.pdf. [Accessed September 2021].
- Cowardin, L.M. 1979. *Classification of Wetland and Deepwater Habitats of the United States*. Jamestown (ND): Northern Prairie Wildlife Research Center, US Fish and Wildlife Service.
- Natural Resources Conservation Service (NRCS). 2006. *Hydric Soils List: Clackamas County, Oregon*. Washington (DC): US Department of Agriculture.
- Natural Resources Conservation Service (NRCS). 2014a. *Official soil series descriptions*. Washington (DC): US Department of Agriculture. Available at: http://www.nrcs.usda.gov/wps/portal/nrcs/detailfull/soils/home/?cid=nrcs142p2_053587. [Accessed September 2021].
- Natural Resources Conservation Service (NRCS). 2014b. *Web soil survey*. Washington (DC): US Department of Agriculture. Available at: <http://websoilsurvey.nrcs.usda.gov/app/>. [Accessed September 2021].
- Oregon Map. 2019. Clackamas County Assessor's Map 3 1 W 12D. Oregon: State of Oregon. Available at: <http://www.ormap.net/>. [Accessed September 2021].
- Roth, E.M., R.D. Olsen, P.L. Snow, and R.R. Sumner. April 1996. *Oregon Freshwater Wetland Assessment Methodology*, Ed. By S.G. McCannell. Oregon Division of State Lands. Salem. OR.
- Wakeley, J.S., R.W. Lichvar, and C.V. Noble, eds. 2010. *Regional Supplement to the Corps of Engineers Wetland Delineation Manual: Western Mountains, Valleys, and Coast Region (Version 2.0)*. ERDC/EL TR-10-3. Vicksburg (MS): US Army Engineer Research and Development Center, US Army Corps of Engineers.
- Wilsonville. 2018. *January 2015 Development Code (as amended through October 2018)*. Wilsonville (OR): City of Wilsonville. Available at: <https://www.ci.wilsonville.or.us/planning/page/development-code> [Accessed September 2021].

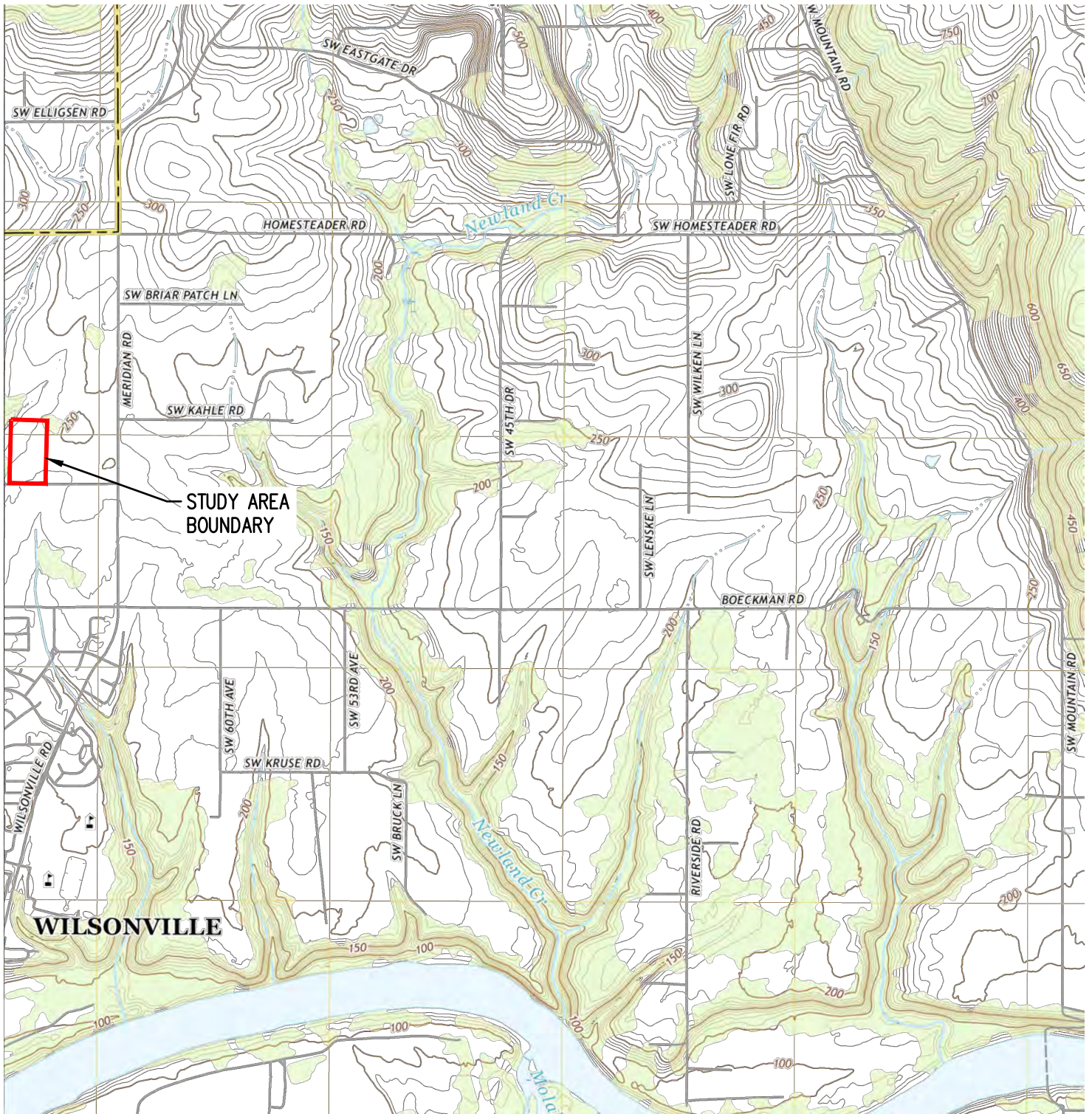

USGS 7.5' TOPOGRAPHIC SERIES
 QUADRANGLE: CANBY, OR (2020)

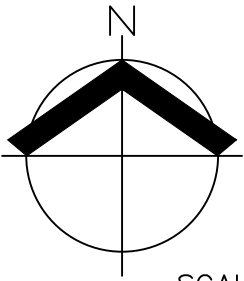

SCALE: 1" = 2000 FEET

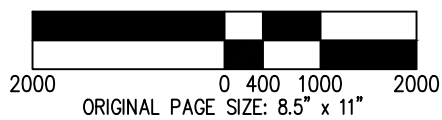

DATE: 09/29/2021

**USGS VICINITY MAP
 FROG POND OAKS SROZ MAP VERIFICATION**

AKS ENGINEERING & FORESTRY, LLC
 12965 SW HERMAN RD, STE 100
 TUALATIN, OR 97062
 503.563.6151 WWW.AKS-ENG.COM

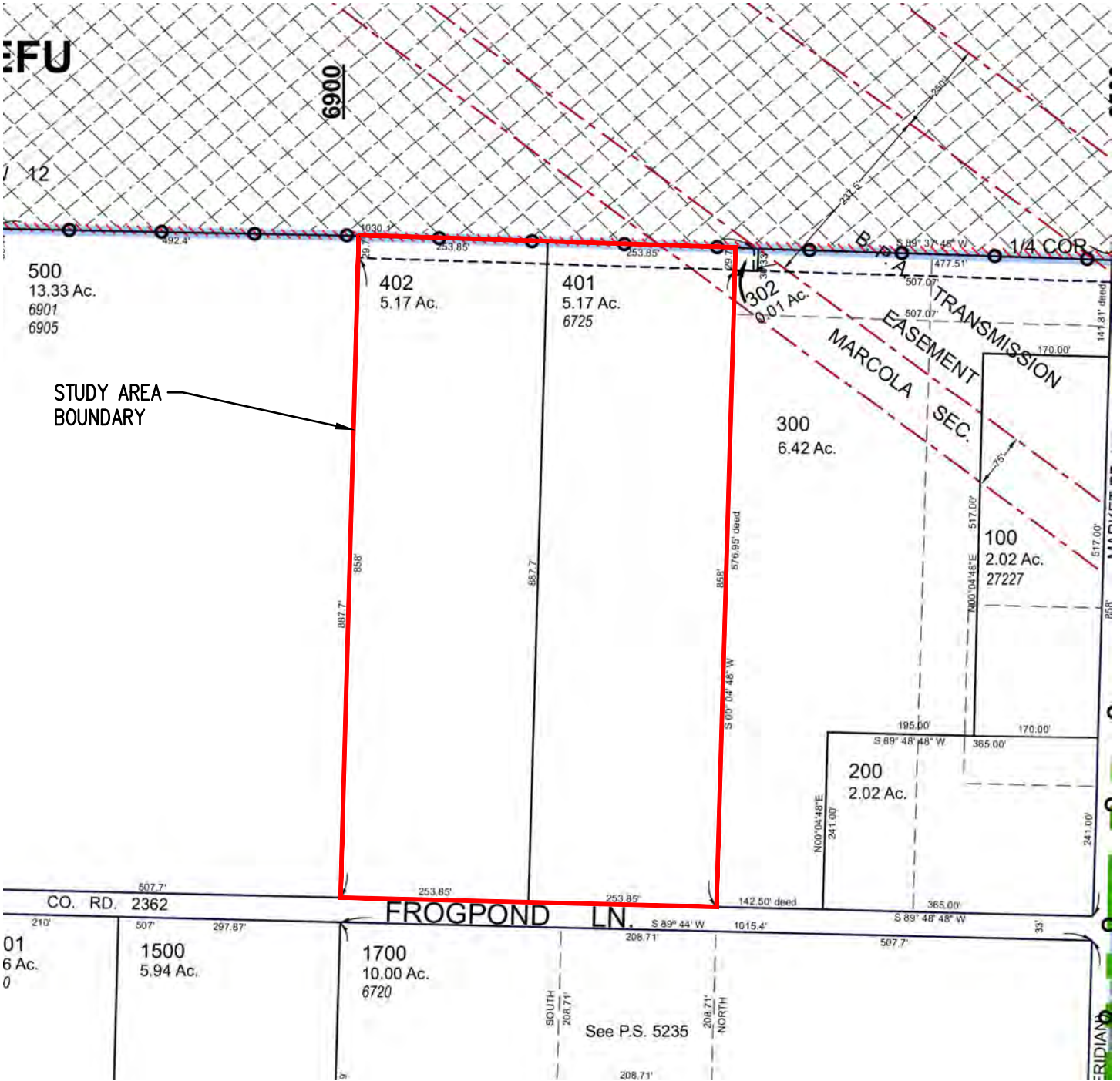

FIGURE
1

DRWN: SKT
 CHKD: SAR
 AKS JOB:
 7005

EFU

12



CLACKAMAS COUNTY
 TAX LOTS 401 & 402
 TAX MAP 3 1W 12D

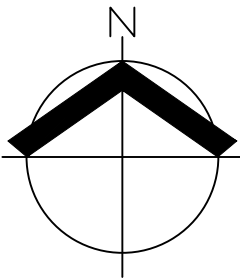

SCALE: 1" = 200 FEET

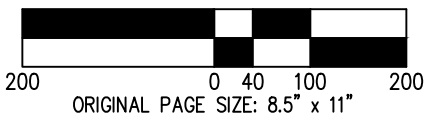

DATE: 09/29/2021

TAX MAP (MAP 3 1W 12D)
FROG POND OAKS SROZ MAP VERIFICATION

AKS ENGINEERING & FORESTRY, LLC
 12965 SW HERMAN RD, STE 100
 TUALATIN, OR 97062
 503.563.6151 WWW.AKS-ENG.COM

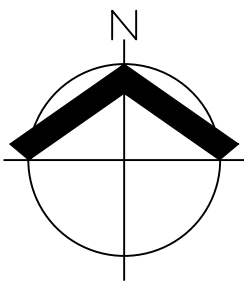

FIGURE
2
 DRWN: SKT
 CHKD: SAR
 AKS JOB:
 7005



MAP UNIT SYMBOL	MAP UNIT NAME
1A	ALOHA SILT LOAM, 0% TO 3% SLOPES; NON-HYDRIC
91B	WOODBURN SILT LOAM, 3% TO 85% SLOPES; NON-HYDRIC

NRCS WEB SOIL SURVEY FOR
CLACKAMAS COUNTY



SCALE: 1" = 200 FEET

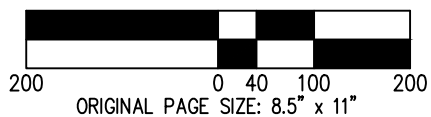









DATE: 09/29/2021

NRCS SOIL SURVEY MAP FROG POND OAKS SROZ MAP VERIFICATION		FIGURE 3
AKS ENGINEERING & FORESTRY, LLC 12965 SW HERMAN RD, STE 100 TUALATIN, OR 97062 503.563.6151 WWW.AKS-ENG.COM		DRWN: SKT CHKD: SAR AKS JOB: 7005





STUDY AREA BOUNDARY

Wetlands		
	Estuarine and Marine Deepwater	 Freshwater Emergent Wetland
	Estuarine and Marine Wetland	 Freshwater Forested/Shrub Wetland
		 Freshwater Pond
		 Lake
		 Other
		 Riverine

US FISH & WILDLIFE SERVICE
NATIONAL WETLANDS INVENTORY

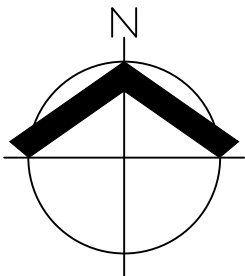

SCALE: 1" = 250 FEET

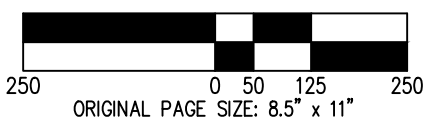

DATE: 09/29/2021

NATIONAL WETLANDS INVENTORY MAP FROG POND OAKS SROZ MAP VERIFICATION		FIGURE 4
AKS ENGINEERING & FORESTRY, LLC 12965 SW HERMAN RD, STE 100 TUALATIN, OR 97062 503.563.6151 WWW.AKS-ENG.COM		DRWN: SKT CHKD: SAR AKS JOB: 7005



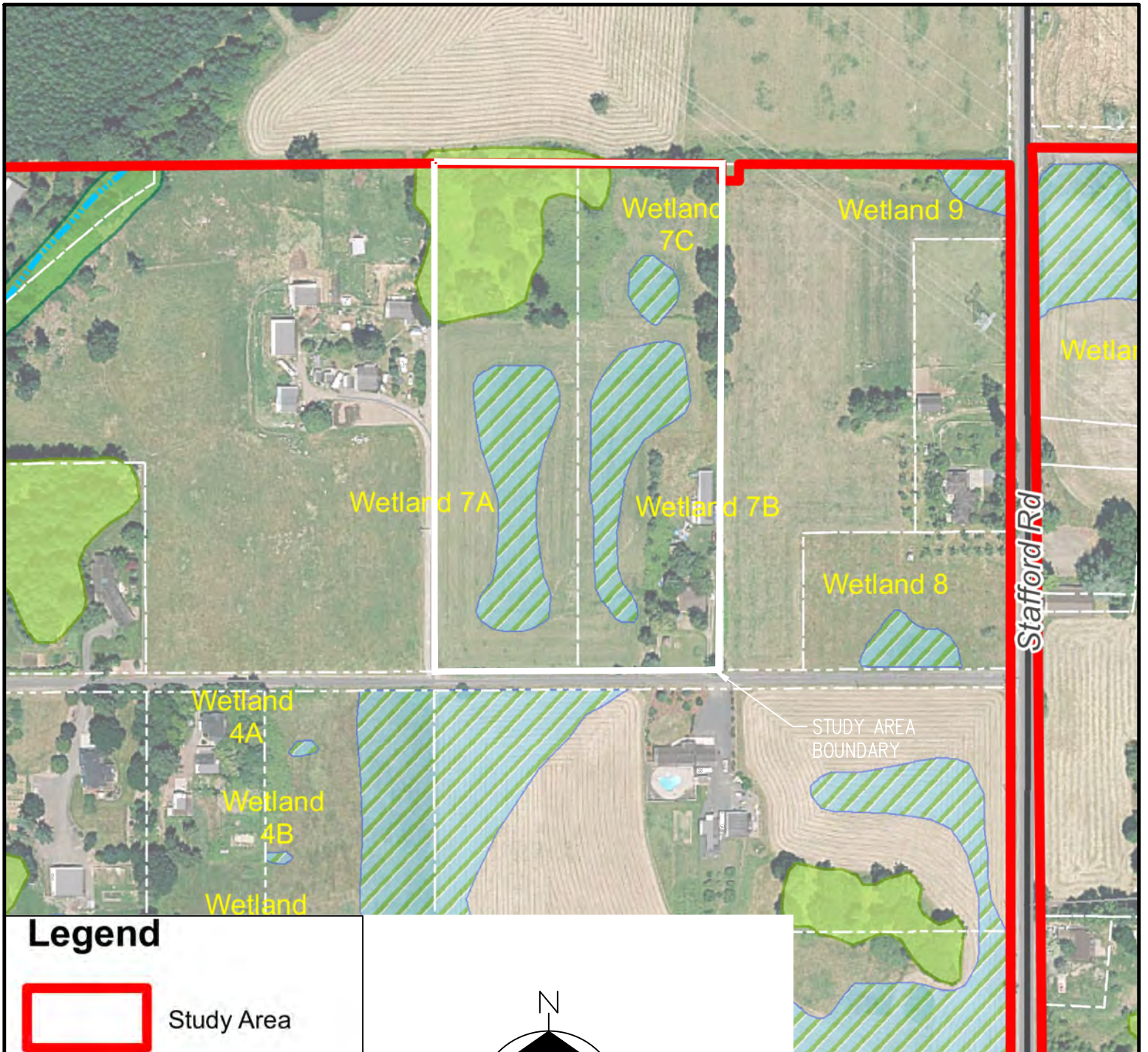

Legend

-  Study Area
-  Streams
-  Tree Groves
-  Wetlands
-  Riparian Areas

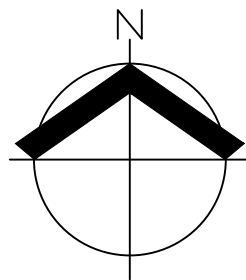

SCALE: 1" = 250 FEET

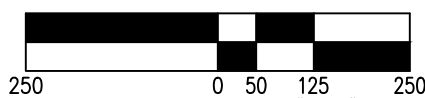

ORIGINAL PAGE SIZE: 8.5" x 11"

PACIFIC HABITAT SERVICES FROG POND AND
ADVANCE ROAD URBAN GROWTH AREAS
NATURAL RESOURCE INVENTORY (2014)

DATE: 09/29/2021

**PHS FROG POND UGB AREA PLANNING MAP
FROG POND OAKS SROZ MAP VERIFICATION**

FIGURE
5

AKS ENGINEERING & FORESTRY, LLC
12965 SW HERMAN RD, STE 100
TUALATIN, OR 97062
503.563.6151 WWW.AKS-ENG.COM



DRWN: SKT
CHKD: SAR
AKS JOB:
7005

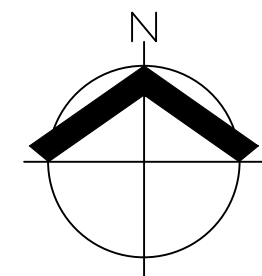
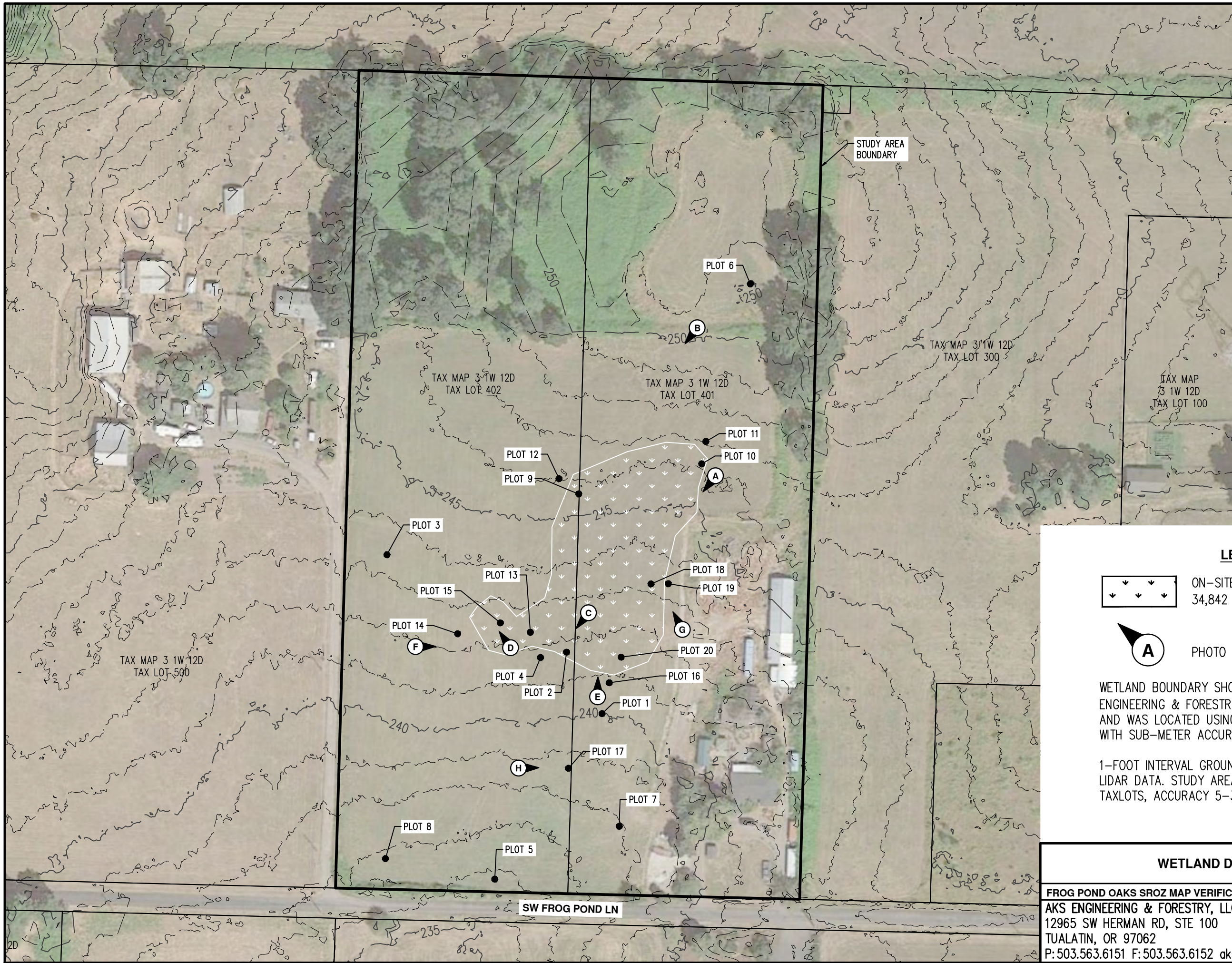

SCALE: 1" = 100 FEET

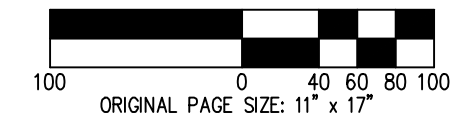

LEGEND

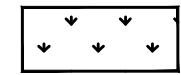

ON-SITE PEM/SLOPE WETLAND AREA:
34,842 SF± (0.80 ACRES±)



PHOTO LOCATION & ORIENTATION

WETLAND BOUNDARY SHOWN WAS DELINEATED BY AKS ENGINEERING & FORESTRY, LLC (AKS) ON MARCH 31, 2021 AND WAS LOCATED USING A HANDHELD GEO7X GPS RECEIVER WITH SUB-METER ACCURACY.

1-FOOT INTERVAL GROUND CONTOURS DERIVED FROM NOAA LIDAR DATA. STUDY AREA BOUNDARY DERIVED FROM GIS TAXLOTS, ACCURACY 5-3 FEET±.

DATE: 09/29/2021

WETLAND DELINEATION	FIGURE
FROG POND OAKS SROZ MAP VERIFICATION	6
AKS ENGINEERING & FORESTRY, LLC 12965 SW HERMAN RD, STE 100 TUALATIN, OR 97062 P: 503.563.6151 F: 503.563.6152 aks-eng.com	DRWN: SKT CHKD: SAR AKS JOB: 7005



Appendix A: Site Representative Photos



Photo A. View south of wetland.



Photo B. View south of wetland in background.



Photo C. View southwest of wetland.



Photo D. View northwest of wetland.



Photo E. View north of wetland. Upland Plot 16 in foreground.



Photo F. View east of wetland.

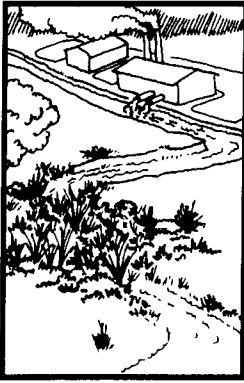

Photo G. View north of eastern wetland boundary.



Photo H. View of east of upland. Plot 17 in photo.

Appendix B: OFWAM Assessment for Water Quality and Hydrologic Control Functions



Water quality (pollutant removal)

Sediment trapping

During periods of heavy rainfall, water runoff may cause erosion and increase solids suspended in receiving surface waters. The excess sediment entering water systems can damage aquatic ecosystems. For example, sediment accumulation in stream bottoms can smother spawning areas and kill aquatic insect larvae. It can also reduce the storage capacity of downstream water supply reservoirs.

Wetlands perform an important function by trapping sediment from waters that pass through them. As water flows through wetlands, it is slowed by vegetation, and sediment settles to the bottom before the water moves farther downstream. As much as 90% of the solids suspended in the water may be removed as the water moves through wetlands, resulting in cleaner water entering streams, rivers, lakes and estuaries.

Nutrient attenuation

Nitrogen and phosphorus are the two nutrients most often associated with water pollution. They are also main ingredients of fertilizers used on agricultural fields and lawns, and both are found in high concentrations in discharges from sewage treatment plants and livestock operations. Excessive amounts of nitrogen and phosphorus in lakes and slow-moving streams can cause algal blooms and subsequent oxygen deficiencies, which may kill fish and reduce water quality. The processes that occur as a result of excess nutrients are lumped together under the term “eutrophication.” Within limits, wetlands can reduce nutrient levels so that the effects of eutrophication on downstream areas are prevented or reduced. This index considers only point and non-point pollutant sources that are due to land uses in the watershed.

Assessment questions

Question 1

What is the wetland’s primary source of water?

- a. Surface flow, including streams and ditches.
- b. Precipitation or sheet flow.
- c. Groundwater, including seeps and springs.

Directions

See question 36 in the Wetland Characterization.

Rationale

Wetlands bordering a perennial or intermittent stream or lake are areas into which floodwaters spread during periods of high runoff, enabling the wetlands to remove pollutants.

Notes

Question 2

- Is there evidence of flooding or ponding during a portion of the growing season?
- a. Yes.
 - b. Unable to determine or not applicable.
 - c. No.

Directions

See question 37 in the Wetland Characterization.

Rationale

Water level fluctuation in the wetland indicates the ability to retain water. Impounded or standing water acts as a sediment trap because it greatly slows the flow of the incoming water, allowing suspended solids to settle out. Additionally, the slower velocity increases the contact time of the water with vegetation, resulting in uptake of nutrients by the vegetation. These actions function to reduce pollutant loads.

Question 3

- What is the degree of wetland vegetation cover?
- a. High (greater than 60%).
 - b. Moderate (approximately 60%).
 - c. Low (less than 60%).

Directions

See question 21 in the Wetland Characterization. Add the lower end of the ranges for forest, scrub-shrub and emergent vegetation to get the result. If the result is 60% or more, answer "high." If the result is 60%, answer "moderate." Answer "low" for other results.

Rationale

The more dense the vegetation, the greater the wetland's ability to take up nutrients. A dense stand of persistent emergent plants (such as cattail and rush) along with floating and submerged aquatics would tend to provide maximum nutrient uptake during the growing season. Wooded and scrub-shrub wetlands remove nutrients mainly through settling of suspended solids in runoff and flood waters.

Notes

Question 4

What is the wetland's area in acres?

Directions

See questions 17 and 27 in the Wetland Characterization.

- a. More than 5 acres.
- b. Between 0.5 acres and 5 acres; or wetland area is less than 0.5 acres, and the wetland is connected to other wetlands within a 3-mile radius by a perennial or intermittent stream, irrigation or drainage ditch, canal or lake.
- c. Less than 0.5 acres, and the wetland is not connected to other wetlands within a 3-mile radius by a perennial or intermittent stream, irrigation or drainage ditch, canal or lake.

Rationale

The larger the wetland, the greater its capacity and ability to filter pollutants. Small wetlands connected by surface water act as a series of filters and thus function similarly to a larger wetland.

Question 5

What is the dominant, existing land use within 500 feet of the wetland's edge?

Directions

Refer to the directions for question 8 of the wildlife habitat assessment questions.

- a. Developed uses.
- b. Agriculture.
- c. Exclusive Forest Use or Open Space.

Rationale

Urbanized areas have more impervious surface areas and concentrate pollution sources. Wetlands in urban areas are important for filtering the runoff water before it enters a stream.

Notes

Question 6

What is the water quality condition of stream reaches in the watershed upstream of the wetland or adjacent to the wetland?

Directions

See questions 7 and 8 in the Wetland Characterization. If both “a” and “b” apply, choose “a.”

- a. One or more upstream or adjacent reaches are listed as *water quality limited* or in *severe* water quality condition for nonpoint source pollutants.
- b. One or more upstream or adjacent reaches are listed in *moderate* water quality condition for nonpoint source pollutants.
- c. No upstream or adjacent reaches are listed as *water quality limited*, and all upstream or adjacent reaches are listed as *no problem* (or no data available) for nonpoint source pollutants.

Notes

Rationale

A watershed with upstream pollutant loading sources needs wetlands to reduce pollutant levels in water before it is delivered downstream.

Water quality: assessment criteria

A wetland’s water-quality function is intact if:

Question 1 is answered “a” or “b,” questions 2 and 3 are answered “a,” and any other question is answered “a” or “b.”

A wetland’s water-quality function is impacted or degraded if:

Answers do not satisfy the above- or below-listed criteria.

A wetland’s water-quality function is lost or not present if:

Four out of six questions are answered “c.”



Frog Pond Oaks- PEM
Wetland

Hydrologic control (flood control & water supply)

Wetlands function as natural water-storage areas during periods of high runoff and stream flooding.

At times they act as flood regulators by holding floodwater then slowly releasing it downstream. This temporary storage reduces the amount of water downstream during floods, thereby reducing peak flows. Through this flood storage mechanism, wetlands associated with tributaries of streams or rivers can prevent water from all tributaries reaching the stream or river at the same time (this is called desynchronization). Wetlands can also act as floodwater “brakes.” For example, water flowing through riverine wetlands during floods is slowed by trees, shrubs, reeds, rushes and other wetland vegetation. Wetlands acting as brakes can reduce flood peaks and thereby reduce flood damage, bank and bed erosion, and other adverse effects caused by fast moving water.

Wetlands also have long-term water holding abilities. Wetlands may store water for longer periods, sometimes for months. The slow draining of these wetlands to surface water or ground water as the water level in the wetland recedes may contribute to maintenance of baseflows in streams hydrologically connected to the wetland. The ability of this long-term water storage to maintain stream flows is called “flow conservation.”

Assessment questions

Question 1

Is all or part of the wetland located within the 100-year floodplain or within an enclosed basin? a. Yes. b. No.

Directions

See question 19 in the Wetland Characterization.

Rationale

Wetlands located within a floodplain or enclosed basin have a greater opportunity to receive and store water from surface flows and to release it slowly downstream or into the groundwater.

Notes

Question 2

- Is there evidence of flooding or ponding during a portion of the growing season?
- a. Yes.
 - b. Unable to determine or not applicable.
 - c. No.

Directions

See question 37 in the Wetland Characterization.

Rationale

Water marks are valid indicators of seasonal and episodic stage fluctuations in wetlands and, as such, are strong indicators of storage function.

Question 3

- What is the wetland's area in acres?
- a. More than 5 acres.
 - b. Between .5 acres and 5 acres.
 - c. Less than .5 acres.

Directions

See question 17 in the Wetland Characterization.

Rationale

Generally, the larger the wetland, the greater its ability to store and attenuate flood flows.

Question 4

- Is waterflow out of the wetland restricted (e.g., beaver dam, concrete structure, undersized culvert)?
- a. Yes, the outlet is restricted or the wetland has no outlet.
 - b. Minor restrictions slow down the water (i.e., undersized culvert.)
 - c. No, the outlet has unrestricted flow.

Directions

See question 38 in the Wetland Characterization.

Rationale

Wetlands with no outlets or with restricted or controlled outlets generally will store greater amounts of water than wetlands with unrestricted flow outlets. Also, the wetland can store water for slower release into the water system.

Question 5

What is the dominant wetland vegetation cover type?

- a. Woody vegetation.
- b. Emergent vegetation and ponding, or open water only.
- c. Emergent vegetation or wet meadow.

Directions

See question 23 in the Wetland Characterization.

Rationale

Densely vegetated wetlands with vegetation greater than 6 feet tall are better able to control flood flows than wetlands dominated by open water or low growing vegetation, which generally offers little resistance.

Question 6

What is the dominant existing land use, within 500 feet of the wetland on the downstream or down-slope edge of the wetland?

- a. Developed uses.
- b. Agriculture.
- c. Exclusive Forest Use and Open Space.

Directions

See question 16 in the Wetland Characterization.

Rationale

If the wetland is upstream from developed areas, its ability to control floods becomes more important.

Question 7

What is the dominant land use in the watershed upstream from the assessment area?

- a. Urban or urbanizing.
- b. Agriculture.
- c. Forested or natural area.

Directions

See question 6 in the Wetland Characterization.

Rationale

Runoff volume is directly related to the level of development in the watershed: The more development, the more runoff. The opportunity for the wetland to provide flood control and flow conservation to a community is greater where runoff is greater.

Notes

Notes

Hydrologic control: assessment criteria

A wetland's hydrologic control function is intact if: Four or more questions are answered "a."

A wetland's hydrologic control function is impacted or degraded if: Answers do not satisfy the above- or below-listed criteria.

A wetland's hydrologic control function is lost or not present if: Four or more questions are answered "c."

Appendix E

Arborist Report dated January 7, 2022, by Portland Tree Consulting



Frog Pond Oaks (Miller Property) Arborist Report

This Tree Plan is required by Section 4.610.40. Type C Permit as part of the site development application for the Miller Property subdivision in Wilsonville, Oregon. Trees were measured by a licensed surveyor and seven of them were inventoried by an ISA Certified Arborist. The attached Tree Table includes all trees that are 6 inches in diameter and larger. There are one hundred-four trees and the Tree Table delineates those to be protected and those to be removed. Root protection zones (RPZs) for protected trees are listed in the tree table.

A tree easement will be placed on Lots 28, 29, 30, 31, 33 and 40 to preserve the root crowns of protected trees that will be in the backyards of these lots. Landscape plans not covered here must be approved by and an ISA Certified Arborist. Following are the requirements and restrictions of the easement:

1. The top organic layer (turf layer) of soil may be removed to facilitate landscape construction.
2. A layer of geo-textile fabric shall be applied to the native soil to provide a barrier between the root zone and landscaping.
3. Mulch and native plantings are encouraged.
4. Impermeable paving within the easement is prohibited.
5. Lawns/turf may be installed on grade on top of the geo-textile fabric. The lawn/turf area must be three feet away from the southern lot line or backyard fence. This three-foot wide area bordering the south lot line must be mulched three inches to four inches deep with woodchips or similar organic material. This area may be used as a planting bed for flowers, woody shrubs, or understory trees. Holes in the landscaping fabric may be cut and the appropriate, sized hole dug for the intended planting. Trees must be installed by a certified landscape professional who will avoid damaging roots.
6. Patios must be constructed on grade and be paved with permeable pavers or permeable concrete to allow water to percolate into the root zone. Patios will not exceed 400 square feet.
7. Tilling of the native soil is not allowed.
8. Raised bed gardens or planting containers may be installed and will not exceed 64 square feet.
9. Play structures and sandboxes are allowed.

The purpose of the tree easement is to preserve the native root zones of the adjacent trees being preserved. The geo-textile fabric provides a barrier between landscaping activities and the root zones beneath, reduces soil compaction during regular use of the backyards, and allows stormwater to pass through to the roots of preserved trees. The preserved trees are currently adapted to competition from a hearty grassland; therefore, the installation of lawns and other plantings is not a concern. The use of chemical fertilizers and herbicides is discouraged. When necessary, the use of chemical agents should be conservative and targeted.

The seventy-six trees being preserved during development will be cordoned off with fencing built at the edge of root protection zones before construction activity begins. Fencing will consist of 6-foot high metal chain link secured with 8-foot metal posts. Without authorization, none of the following is allowed within a root protection zone:

1. New buildings;
2. Grade change or cut and fill, during or after construction;
3. New impervious surfaces;
4. Utility or drainage field placement;
5. Staging or storage of materials and equipment during construction;
6. Vehicle maneuvering during construction.

The northwest portion of the property includes a grove of mature native trees. Site design elements preserve these trees as a group and maintain the character of this native grove. The landscape architect and I will determine the location of the sidewalk in the grove by walking the optimal route through trees and mapping this route in real time using global positioning satellite technology. The finished sidewalk location within the grove will be somewhat flexible to allow the project arborist and construction crew to preserve large roots that may be encountered. The sidewalk will be built on-grade according to the following construction plan:

1. A small sized backhoe on rubber tracks and using a flat bucket, will gradually scrape away the first layer of soil. The project arborist will supervise this work and will advise on root pruning and preservation.
2. A layer of geo-textile fabric will be applied to the native soil where the sidewalk is within the RPZs of protected trees.
3. A two-inch to four-inch layer of crushed rock will be placed on the fabric. This layer of rock will be lightly compacted using a hand operated, motorized compactor.
4. Concrete forms may be installed before or after the crushed rock is added.
5. Concrete will be poured. Concrete will be piped into the grove by a concrete truck that will remain outside of the RPZs of protected trees. Concrete may also be brought into the grove using a power wheelbarrow, skid-steer on rubber tracks, bobcat, or similar piece of equipment.

The project arborist must be onsite during grading for the sidewalk. The above grade work of setting forms installing gravel and pouring concrete will not require arborist oversight. At no time may large trucks or steel-tracked equipment enter the grove. Rock and gravel must be piped or ferried in using the smaller sized equipment described above. This construction plan avoids unnecessary soil compaction within the RPZs of protected trees.

There will be twenty-eight trees removed from the site. Section 4.620.00. requires that each removed tree be replaced with a 2-inch caliper tree within one year of removal. Replacement trees shall be chosen for the site from an approved tree species list supplied by the City and shall be state Department of Agriculture Nursery Grade No. 1 or better. The trees must be staked,

fertilized, and mulched, and shall be guaranteed by the permit grantee for two years after the planting date. The species and locations will be determined by the landscape designer. Alternatively, the owner may invoke Section 4.629.00.(06.) and will pay into the City Tree Fund the value of the replacement trees that cannot be planted at the site.

The goal of this Tree Plan is to meet the requirements of the tree preservation code and to observe all laws, rules, and regulations. All trees to be removed should be verified and marked and all tree protection measures should be inspected and approved before any clearing or grading work begins. It is the owner's responsibility to implement this tree plan and to monitor the construction process to its conclusion. Deviations can result in tree damage, liability, and violations of the City Code.

Portland Tree Consulting PO Box 19042 Portland, OR 97280
503.421.3883 peterortoresusa@gmail.com CCB 230301

1. Client warrants any legal description provided to the Consultant is correct and titles and ownerships to property are good and marketable. Consultant shall not be responsible for incorrect information provided by Client.
2. Consultant can neither guarantee nor be responsible for the accuracy of information provided by others.
3. The Consultant shall not be required to give testimony or attend court or hearings unless subsequent contractual arrangements are made, including additional fees.
4. The report and any values expressed therein represent the opinion of the Consultant, and the Consultant's fee is in no way contingent upon the reporting of a specified value, a stipulated result, the occurrence of a subsequent event, nor upon any finding to be reported.
5. Sketches, drawings and photographs in the report are intended as visual aids and may not be to scale. The reproduction of information generated by others will be for coordination and ease of reference. Inclusion of such information does not warrant the sufficiency or accuracy of the information by the Consultant.
6. Unless expressed otherwise, information in the report covers only items that were examined and reflects the condition at the time of inspection. The inspection is limited to visual examination of accessible items without laboratory analysis, dissection, excavation, probing, or coring, unless otherwise stated.
7. There is no warranty or guarantee, expressed or implied, that problems or deficiencies of the plants or property in question may not arise in the future.
8. The report is the completed work product. Any additional work, including production of a site plan, addenda and revisions, construction of tree protection measures, tree work, or inspection of tree protection measures, for example, must be contracted separately. Loss or alteration of any part of the report invalidates the entire report.
9. Any action or proceeding seeking to enforce any provision of this Agreement shall be brought against any of the parties in Multnomah County Circuit Court of the State of Oregon, or, when applicable, in the United States District Court for the District of Oregon. Each party consents to the jurisdiction of such courts (and of the appropriate appellate courts) and waives any objection to such venue.

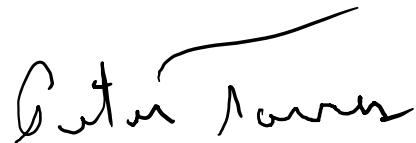

Peter Torres

Master of Forestry ASCA RCA 372 ISA Certified Arborist PN-0650B TRAQ

Appendix F

Geotechnical Report dated December 10, 2021, by
Hardman Geotechnical Services, Inc.



July 17, 2018 (updated December 10, 2021)
HGSI Project No. 18-2338

Dan Grimberg / Kristi Hosea
West Hills Land Development
3330 NW Yeon Avenue, Suite 200
Portland, Oregon 97210

Via e-mail (pdf format); hard copies can be mailed on request

**Subject: GEOTECHNICAL ENGINEERING REPORT
MILLER PROPERTY
6725 SW FROG POND LANE
WILSONVILLE, CLACKAMAS COUNTY, OREGON**

This report presents the results of a geotechnical engineering study conducted by Hardman Geotechnical Services Inc. (HGSI) for the property at 6720 SW Frog Pond Lane in Wilsonville, Oregon (Figure 1). The purpose of this study was to evaluate subsurface conditions at the site and to provide geotechnical recommendations for site development. This geotechnical study was performed in accordance with HGSI Proposal No. 18-763, dated July 2, 2018, and your subsequent authorization of our proposal and *General Conditions for Geotechnical Services*.

SITE DESCRIPTION AND PROPOSED DEVELOPMENT

Our understanding of the site and project conditions is based on a review of information provided, and property data obtained online from Clackamas County. The project consists of two contiguous tax lots, totaling about 10.4 acres, as summarized below. Please note that the parcel addresses and acreages were taken from the Clackamas County GIS website and may not be completely accurate.

Tax Lot No.	Address	Acreage	House Constructed Date
31W12D 00401	Miller Property 6725 SW Frog Pond Lane	5.20	1960
31W12D 00402	No Address	5.22	N/A

The southeast corner of the property has an existing house, and several outbuildings ranging from a small shed to a large barn/shop structure north of the house. Site vegetation consists of lawn, landscaping shrubs and trees around the existing home. The majority of the property is grass field or pasture, with a treed area in the northwest corner. Site slopes are gentle, generally down toward the south. The site is within an area of rural residential properties.

The proposed development includes grading the site to support residential lots, with associated underground utilities, roadways and water quality facilities. Details of the planned lot and street layout, and proposed grading, have been developed and are illustrated on the project plans by Otak. HGSI should review the

grading plan when available to verify consistency with the geotechnical recommendations, and to provide any supplemental or revised input to the design needed based on geotechnical considerations.

REGIONAL GEOLOGY AND SEISMIC SETTING

The subject site lies within the Portland Basin, a broad structural depression situated between the Coast Range on the west and the Cascade Range on the east. The Portland Basin is a northwest-southwest trending structural basin produced by broad regional downwarping of the area. The Portland Basin is approximately 20 miles wide and 45 miles long and is filled with consolidated and unconsolidated sedimentary rocks of late Miocene, Pliocene and Pleistocene age.

The subject site is underlain by Quaternary age (last 1.6 million years) loess, a windblown silt deposit that mantles older deposits and basalt bedrock in the Portland Hills (Madin, 1990). The loess generally consists of massive silt deposited following repeated catastrophic flooding events in the Willamette Valley, the last of which occurred about 10,000 years ago. In localized areas, the loess includes buried paleosols that developed between depositional events. Regionally, the total thickness of loess ranges from 5 feet to greater than 100 feet.

The loess is underlain by residual soil formed by in place weathering of the underlying Columbia River Basalt Formation (Madin, 1990). The Miocene aged (about 14.5 to 16.5 million years ago) Columbia River Basalts are a thick sequence of lava flows which form the crystalline basement of the Tualatin Valley. The basalts are composed of dense, finely crystalline rock that is commonly fractured along blocky and columnar vertical joints. Individual basalt flow units typically range from 25 to 125 feet thick and interflow zones are typically vesicular, scoriaceous, brecciated, and sometimes include sedimentary rocks.

At least three major fault zones capable of generating damaging earthquakes are known to exist in the region. These include the Portland Hills Fault Zone, Gales Creek-Newberg-Mt. Angel Structural Zone, and the Cascadia Subduction Zone. These potential earthquake source zones are included in the determination of seismic design values for structures, as presented in the *Seismic Design* section. None of the known faults extend beneath the site.

FIELD EXPLORATION – HAND AUGER BORINGS

The site-specific exploration for this study was conducted on July 16, 2018 and consisted of six hand auger borings (designated HA-1 through HA-6) excavated to maximum depths of approximately 8 feet below ground surface (bgs) at the approximate locations shown on Figure 2. It should be noted that exploration locations were determined in the field by pacing or taping distances from apparent property corners and other site features shown on the plans provided. As such, the locations of the explorations should be considered approximate.

Explorations were conducted under the full-time observation of HGSI personnel. Soil samples obtained from the borings were classified in the field and representative portions were placed in relatively air-tight plastic bags. These soil samples were then returned to the laboratory for further examination. Pertinent information including soil sample depths, stratigraphy, soil engineering characteristics, and groundwater occurrence was recorded. Soils were classified in general accordance with the Unified Soil Classification System.

Summary exploration logs are attached to this report. The stratigraphic contacts shown on the individual borehole logs represent the approximate boundaries between soil types. The actual transitions may be more gradual. The soil and groundwater conditions depicted are only for the specific dates and locations reported, and therefore, are not necessarily representative of other locations and times.

SUBSURFACE CONDITIONS

The following discussion is a summary of subsurface conditions encountered in our explorations. For more detailed information regarding subsurface conditions at specific exploration locations, refer to the attached hand auger logs. Also, please note that subsurface conditions can vary between exploration locations, as discussed in the *Uncertainty and Limitations* section below.

Soil

On-site soils are anticipated to consist of topsoil, clayey silt, and clay, as described below.

Topsoil – From the ground surface, all explorations encountered 1.5 to 2 feet of topsoil, comprised of moist silt. The upper about 1 foot of the topsoil was highly organic.

Clayey Silt to Silty Clay – Beneath the topsoil in the hand augers, we encountered stiff to very stiff, moist to wet, brown clayey silt to silty clay. The upper several feet of this unit exhibited orange and gray mottling. All of the explorations terminated in the clayey silt to silty clay unit, at maximum depth of about 5 feet bgs.

Groundwater

During the field exploration, no static groundwater table was encountered to the maximum depth of exploration at 8 feet bgs. Slight seepage was encountered in borings HA-1 and HA-4 at about 8 feet bgs. Perched groundwater conditions often occur over fine-grained native deposits such as those beneath the site, particularly during the wet season. It is anticipated that groundwater conditions will vary depending on the season, local subsurface conditions, changes in site utilization, and other factors. The groundwater conditions reported above are for the specific date and locations indicated, and therefore may not necessarily be indicative of other times and/or locations.

CONCLUSIONS AND RECOMMENDATIONS

Results of this study indicate that the proposed development is geotechnically feasible, provided that the recommendations of this report are incorporated into the design and construction phases of the project. Recommendations are presented below regarding site preparation and undocumented fill removal, engineered fill, wet weather earthwork, spread footing foundations, below grade structural retaining walls, concrete slabs-on-grade, perimeter footing drains, seismic design, excavating conditions and utility trench backfill, and erosion control considerations.

Site Preparation and Undocumented Fill Removal

The areas of the site to be graded should first be cleared of vegetation, undocumented fill, and any loose debris; and debris from clearing should be removed from the site. Organic-rich topsoil should then be removed to competent native soils. We anticipate that the average depth of topsoil stripping will be about 12 inches over most of the site, however deeper stripping may be needed in localized areas. The final depth of stripping removal may vary depending on local subsurface conditions and the contractor's methods, and should be determined on the basis of site observations after the initial stripping has been performed. Stripped organic soil should be stockpiled only in designated areas or removed from the site and stripping operations should be observed and documented by HGSI. Existing subsurface structures (tile drains, old utility lines, septic leach fields, etc.) beneath areas of proposed structures and pavement should be removed and the excavations backfilled with engineered fill.

There is potential for old fills to be present on site in areas beyond our explorations. Where encountered beneath proposed structures, pavements, or other settlement-sensitive improvements, undocumented fill

should be removed down to firm inorganic native soils and the removal area backfilled with engineered fill (see below). HGSI should observe removal excavations (if any) prior to fill placement to verify that overexcavations are adequate and an appropriate bearing stratum is exposed.

In construction areas, once stripping has been verified, the area should be ripped or tilled to a depth of 12 inches, moisture conditioned, and compacted in-place prior to the placement of engineered fill. Exposed subgrade soils should be evaluated by HGSI. For large areas, this evaluation is normally performed by proof-rolling the exposed subgrade with a fully loaded scraper or dump truck. For smaller areas where access is restricted, the subgrade should be evaluated by probing the soil with a steel probe. Soft/loose soils identified during subgrade preparation should be compacted to a firm and unyielding condition or over-excavated and replaced with engineered fill, as described below. The depth of overexcavation, if required, should be evaluated by HGSI at the time of construction.

Engineered Fill

In general, we anticipate that on-site soils will be suitable for use as engineered fill in dry weather conditions, provided they are relatively free of organics and are properly moisture conditioned for compaction. Imported fill material must be approved by the geotechnical engineer prior to being imported to the site. Oversize material greater than 6 inches in size should not be used within 3 feet of foundation footings, and material greater than 12 inches in diameter should not be used in engineered fill.

Engineered fill should be compacted in horizontal lifts not exceeding 8 inches using standard compaction equipment. We recommend that engineered fill be compacted to at least 90 percent of the maximum dry density determined by ASTM D1557 (Modified Proctor) or equivalent. On-site soils may be wet or dry of optimum; therefore, we anticipate that moisture conditioning of native soil will be necessary for compaction operations.

Proper test frequency and earthwork documentation usually requires daily observation and testing during stripping, rough grading, and placement of engineered fill. Field density testing should conform to ASTM D2922 and D3017, or D1556. Engineered fill should be periodically observed and tested by the project geotechnical engineer or his representative. Typically, one density test is performed for at least every 2 vertical feet of fill placed or every 500 yd³, whichever requires more testing.

Wet Weather Earthwork

The on-site soils are moisture sensitive and may be difficult to handle or traverse with construction equipment during periods of wet weather. Earthwork is typically most economical when performed under dry weather conditions. Earthwork performed during the wet-weather season will probably require expensive measures such as cement treatment or imported granular material to compact fill to the recommended engineering specifications. If earthwork is to be performed or fill is to be placed in wet weather or under wet conditions when soil moisture content is difficult to control, the following recommendations should be incorporated into the contract specifications.

- Earthwork should be performed in small areas to minimize exposure to wet weather. Excavation or the removal of unsuitable soils should be followed promptly by the placement and compaction of clean engineered fill. The size and type of construction equipment used may have to be limited to prevent soil disturbance. Under some circumstances, it may be necessary to excavate soils with a backhoe to minimize subgrade disturbance caused by equipment traffic;
- The ground surface within the construction area should be graded to promote run-off of surface water and to prevent the ponding of water;

- Material used as engineered fill should consist of clean, granular soil containing less than about 7 percent fines. The fines should be non-plastic. Alternatively, cement treatment of on-site soils may be performed to facilitate wet weather placement;
- The ground surface within the construction area should be sealed by a smooth drum vibratory roller, or equivalent, and under no circumstances should be left uncompacted and exposed to moisture. Soils which become too wet for compaction should be removed and replaced with clean granular materials;
- Excavation and placement of fill should be observed by the geotechnical engineer to verify that all unsuitable materials are removed and suitable compaction and site drainage is achieved; and
- Bales of straw and/or geotextile silt fences should be strategically located to control erosion.

If cement or lime treatment is used to facilitate wet weather construction, HGSI should be contacted to provide additional recommendations and field monitoring.

Spread Footing Foundations

Shallow, conventional isolated or continuous spread footings may be used to support the proposed structures, provided they are founded on competent native soils, or compacted engineered fill placed directly upon the competent native soils. We recommend a maximum allowable bearing pressure of 2,000 pounds per square foot (psf) for designing spread footings bearing on undisturbed native soils or engineered fill. The recommended maximum allowable bearing pressure may be increased by a factor of 1.33 for short term transient conditions such as wind and seismic loading. Exterior footings should be founded at least 18 inches below the lowest adjacent finished grade. Minimum footing widths should be determined by the project engineer/architect in accordance with applicable design codes.

Assuming construction is accomplished as recommended herein, and for the foundation loads anticipated, we estimate total settlement of spread foundations of less than about 1 inch and differential settlement between two adjacent load-bearing components supported on competent soil of less than about ½ inch. We anticipate that the majority of the estimated settlement will occur during construction, as loads are applied.

Wind, earthquakes, and unbalanced earth loads will subject the proposed structure to lateral forces. Lateral forces on a structure will be resisted by a combination of sliding resistance of its base or footing on the underlying soil and passive earth pressure against the buried portions of the structure. For use in design, a coefficient of friction of 0.5 may be assumed along the interface between the base of the footing and subgrade soils. Passive earth pressure for buried portions of structures may be calculated using an equivalent fluid weight of 390 pounds per cubic foot (pcf), assuming footings are cast against dense, natural soils or engineered fill. The recommended coefficient of friction and passive earth pressure values do not include a safety factor. The upper 12 inches of soil should be neglected in passive pressure computations unless it is protected by pavement or slabs on grade.

Footing excavations should be trimmed neat and the bottom of the excavation should be carefully prepared. Loose, wet or otherwise softened soil should be removed from the footing excavation prior to placing reinforcing steel bars. HGSI should observe foundation excavations prior to placing crushed rock, to verify that adequate bearing soils have been reached. Due to the high moisture sensitivity of on-site soils, construction during wet weather may require overexcavation of footings and backfill with compacted, crushed aggregate.

Below-Grade Structural Retaining Walls

Lateral earth pressures against below-grade retaining walls will depend upon the inclination of any adjacent slopes, type of backfill, degree of wall restraint, method of backfill placement, degree of backfill compaction, drainage provisions, and magnitude and location of any adjacent surcharge loads. At-rest soil pressure is

exerted on a retaining wall when it is restrained against rotation. In contrast, active soil pressure will be exerted on a wall if its top is allowed to rotate or yield a distance of roughly 0.001 times its height or greater. If the subject retaining walls will be free to rotate at the top, they should be designed for an active earth pressure equivalent to that generated by a fluid weighing 35 pcf for level backfill against the wall. For restrained walls, an at-reset equivalent fluid pressure of 54 pcf should be used in design, again assuming level backfill against the wall. These values assume that the recommended drainage provisions are incorporated, and hydrostatic pressures are not allowed to develop against the wall.

During a seismic event, lateral earth pressures acting on below-grade structural walls will increase by an incremental amount that corresponds to the earthquake loading. Based on the Mononobe-Okabe equation and peak horizontal accelerations appropriate for the site location, seismic loading should be modeled using the active or at-rest earth pressures recommended above, plus an incremental rectangular-shaped seismic load of magnitude $5H$, where H is the total height of the wall.

We assume relatively level ground surface below the base of the walls. As such, we recommend passive earth pressure of 390 pcf for use in design, assuming wall footings are cast against competent native soils or engineered fill. If the ground surface slopes down and away from the base of any of the walls, a lower passive earth pressure should be used and HGSI should be contacted for additional recommendations.

A coefficient of friction of 0.5 may be assumed along the interface between the base of the wall footing and subgrade soils. The recommended coefficient of friction and passive earth pressure values do not include a safety factor, and an appropriate safety factor should be included in design. The upper 12 inches of soil should be neglected in passive pressure computations unless it is protected by pavement or slabs on grade.

The above recommendations for lateral earth pressures assume that the backfill behind the subsurface walls will consist of properly compacted structural fill, and no adjacent surcharge loading. If the walls will be subjected to the influence of surcharge loading within a horizontal distance equal to or less than the height of the wall, the walls should be designed for the additional horizontal pressure. For uniform surcharge pressures, a uniformly distributed lateral pressure of 0.3 times the surcharge pressure should be added.

The recommended equivalent fluid densities assume a free-draining condition behind the walls so that hydrostatic pressures do not build up. This can be accomplished by placing a 12-inch wide zone of crushed drain rock containing less than 5 percent fines against the walls. A 3-inch minimum diameter perforated, plastic drain pipe should be installed at the base of the walls and connected to a sump to remove water from the crushed drain rock zone. The drain pipe should be wrapped in filter fabric (Mirafi 140N or other as approved by the geotechnical engineer) to minimize clogging. The above drainage measures are intended to remove water from behind the wall to prevent hydrostatic pressures from building up. Additional drainage measures may be specified by the project architect or structural engineer, for damp-proofing or other reasons.

HGSI should be contacted during construction to verify subgrade strength in wall keyway excavations, to verify that backslope soils are in accordance with our assumptions, and to take density tests on the wall backfill materials.

Concrete Slabs-on-Grade

Preparation of areas beneath concrete slab-on-grade floors should be performed as recommended in the *Site Preparation* section. Care should be taken during excavation for foundations and floor slabs, to avoid disturbing subgrade soils. If subgrade soils have been adversely impacted by wet weather or otherwise disturbed, the surficial soils should be scarified to a minimum depth of 8 inches, moisture conditioned to within about 3 percent of optimum moisture content, and compacted to engineered fill specifications. Alternatively, disturbed soils may be removed and the removal zone backfilled with additional crushed rock.

For evaluation of the concrete slab-on-grade floors using the beam on elastic foundation method, a modulus of subgrade reaction of 200 kcf (115 pci) should be assumed for the soils anticipated at subgrade depth. This value assumes the concrete slab system is designed and constructed as recommended herein, with a minimum thickness of crushed rock of 8 inches beneath the slab.

Interior slab-on-grade floors should be provided with an adequate moisture break. The capillary break material should consist of ODOT open graded aggregate per ODOT Standard Specifications 02630-2. The minimum recommended thickness of capillary break materials on re-compacted soil subgrade is 8 inches. The total thickness of crushed aggregate will be dependent on the subgrade conditions at the time of construction, and should be verified visually by proof-rolling. Under-slab aggregate should be compacted to at least 90% of its maximum dry density as determined by ASTM D1557 or equivalent.

In areas where moisture will be detrimental to floor coverings or equipment inside the proposed structure, appropriate vapor barrier and damp-proofing measures should be implemented. A commonly applied vapor barrier system consists of a 10-mil polyethylene vapor barrier placed directly over the capillary break material. With this type of system, an approximately 2-inch thick layer of sand is often placed over the vapor barrier to protect it from damage, to aid in curing of the concrete, and also to help prevent cement from bleeding down into the underlying capillary break materials. Other damp/vapor barrier systems may also be feasible. Appropriate design professionals should be consulted regarding vapor barrier and damp proofing systems, ventilation, building material selection and mold prevention issues, which are outside HGSI's area of expertise.

Perimeter Footing Drains

Due to the potential for perched surface water above fine grained deposits such as those encountered at the site, we recommend the outside edge of perimeter footings be provided with a drainage system consisting of 3-inch minimum diameter perforated PVC pipe embedded in a minimum of 1 ft³ per lineal foot of clean, free-draining sand and gravel or 1"- 1/4" drain rock. The drain pipe and surrounding drain rock should be wrapped in non-woven geotextile (Mirafi 140N, or approved equivalent) to minimize the potential for clogging and/or ground loss due to piping. Water collected from the footing drains should be directed into the local storm drain system or other suitable outlet. A minimum 0.5 percent fall should be maintained throughout the drain and non-perforated pipe outlet. The footing drains should include clean-outs to allow periodic maintenance and inspection.

Down spouts and roof drains should collect roof water in a system separate from the footing drains in order to reduce the potential for clogging. Roof drain water should be directed to an appropriate discharge point well away from structural foundations. Grades should be sloped downward and away from buildings to reduce the potential for ponded water near structures.

Seismic Design

Structures should be designed to resist earthquake loading in accordance with the methodology described in the current Oregon Residential Specialty Code (ORSC). We recommend Site Class D (Stiff Soils) be used for design per the ORSC. Design values determined for the site using the ASCE 7-16 Hazard Tool are summarized on Table 1, for Risk Category II.

Table 1. Recommended Earthquake Ground Motion Parameters (ASCE 7-16)

Parameter	Value
Location (Lat, Long), degrees	45.3234, -122.7469
Mapped Spectral Acceleration Values (MCE, Site Class B):	
Short Period, S_s	0.821 g
1.0 Sec Period, S_1	0.381 g
Design Values for Site Class D (Stiff Soils):	
Peak Ground Acceleration PGA_M	0.458
F_a	1.172
$SD_s = 2/3 \times F_a \times S_s$	0.641 g
Seismic Design Category (2021 ORSC)	D ₀

Potential seismic impacts also include secondary effects such as soil liquefaction, fault rupture potential, and other hazards as discussed below:

- **Soil Liquefaction Potential** – Soil liquefaction is a phenomenon wherein saturated soil deposits temporarily lose strength and behave as a liquid in response to earthquake shaking. Soil liquefaction is generally limited to loose, granular soils located below the water table. Following development, on-site soils will consist predominantly of engineered fill or stiff clayey native soils above the water table, which are not considered susceptible to liquefaction. Therefore, it is our opinion that special design or construction measures are not required to mitigate the effects of liquefaction.
- **Fault Rupture Potential** – Based on our review of available geologic literature, we are not aware of any mapped active (demonstrating movement in the last 10,000 years) faults on the site. During our field investigation, we did not observe any evidence of surface rupture or recent faulting. Therefore, we conclude that the potential for fault rupture on site is low.
- **Seismic Induced Landslide** – Topography in the vicinity of the subject site is generally flat to gently sloping. The potential for slope instability and seismic induced landslide on site is considered very low.
- **Effects of Local Geology and Topography** – In our opinion, no additional seismic hazard will occur due to local geology or topography. The site is expected to have no greater seismic hazard than surrounding properties and the Wilsonville area in general.

Excavating Conditions and Utility Trench Backfill

We anticipate that on-site soils can be excavated using conventional heavy equipment such as scrapers and trackhoes to a depth of 8 feet and likely greater. Maintenance of safe working conditions, including temporary excavation stability, is the responsibility of the contractor. Actual slope inclinations at the time of construction should be determined based on safety requirements and actual soil and groundwater conditions. All temporary cuts in excess of 4 feet in height should be sloped in accordance with U.S. Occupational Safety and Health Administration (OSHA) regulations (29 CFR Part 1926), or be shored. The existing native soils classify as Type B Soil and temporary excavation side slope inclinations as steep as 1H:1V may be assumed for planning purposes. This cut slope inclination is applicable to excavations above the water table only.

Perched groundwater conditions often occur over fine-grained native deposits such as those beneath the site, particularly during the wet season. If encountered, the contractor should be prepared to implement an appropriate dewatering system for installation of the utilities. At this time, we anticipate that dewatering systems consisting of ditches, sumps and pumps would be adequate for control of groundwater where encountered during construction conducted during the dry season. Regardless of the dewatering system used, it should be installed and operated such that in-place soils are prevented from being removed along with the groundwater.

Vibrations created by traffic and construction equipment may cause some caving and raveling of excavation walls. In such an event, lateral support for the excavation walls should be provided by the contractor to prevent loss of ground support and possible distress to existing or previously constructed structural improvements.

Utility trench backfill should consist of ¾"-0 crushed rock, compacted to at least 90% of the maximum dry density obtained by Modified Proctor (ASTM D1557) or equivalent. Initial backfill lift thicknesses for a ¾"-0 crushed aggregate base may need to be as great as 4 feet to reduce the risk of flattening underlying flexible pipe. Subsequent lift thickness should not exceed 1 foot. If imported granular fill material is used, then the lifts for large vibrating plate-compaction equipment (e.g. hoe compactor attachments) may be up to 2 feet, provided that proper compaction is being achieved and each lift is tested. Use of large vibrating compaction equipment should be carefully monitored near existing structures and improvements due to the potential for vibration-induced damage.

Adequate density testing should be performed during construction to verify that the recommended relative compaction is achieved. Typically, one density test is taken for every 4 vertical feet of backfill on each 200-lineal-foot section of trench.

Erosion Control Considerations

During our field exploration program, we did not observe soil types that would be considered highly susceptible to erosion. Erosion at the site during construction can be minimized by implementing the project erosion control plan, which should include judicious use of straw, bio-bags, silt fences, or other appropriate technology. Where used, erosion control devices should be in place and remain in place throughout site preparation and construction. Areas of exposed soil requiring immediate and/or temporary protection against exposure should be covered with either mulch or erosion control netting/blankets.

UNCERTAINTIES AND LIMITATIONS

We have prepared this report for the owner and his/her consultants for use in design of this project only. This report should be provided in its entirety to prospective contractors for bidding and estimating purposes; however, the conclusions and interpretations presented in this report should not be construed as a warranty of the subsurface conditions. Experience has shown that soil and groundwater conditions can vary significantly over small distances. Inconsistent conditions can occur between explorations that may not be detected by a geotechnical study. If, during future site operations, subsurface conditions are encountered which vary appreciably from those described herein, HGSI should be notified for review of the recommendations of this report, and revision of such if necessary.

Sufficient geotechnical monitoring, testing and consultation should be provided during construction to confirm that the conditions encountered are consistent with those indicated by explorations. Recommendations for design changes will be provided should conditions revealed during construction differ from those anticipated, and to verify that the geotechnical aspects of construction comply with the contract plans and specifications.

July 17, 2018 (updated December 10, 2021)

HGSI Project No. 18-2338

Within the limitations of scope, schedule and budget, HGSI executed these services in accordance with generally accepted professional principles and practices in the field of geotechnical engineering at the time the report was prepared. No warranty, expressed or implied, is made. The scope of our work did not include environmental assessments or evaluations regarding the presence or absence of wetlands or hazardous or toxic substances in the soil, surface water, or groundwater at this site.



We appreciate this opportunity to be of service.

Sincerely,

HARDMAN GEOTECHNICAL SERVICES INC.



EXPIRES: 06-30-2023

Scott L. Hardman, P.E., G.E.
Geotechnical Engineer

- Attachments: References
- Figure 1 – Vicinity Map
- Figure 2 – Site Plan
- Logs of Hand Auger Borings HA-1 through HA-6
- ASCE 7-16 Seismic Hazard Tool Output (3 Sheets)



REFERENCES

Beeson, M.H., Tolan, T.L., and Madin, I.P., 1991, Geologic map of the Portland Quadrangle, Multnomah, and Washington Counties, Oregon: Oregon Department of Geology and Mineral Industries Geological Map Series GMS-75, scale 1:24,000.

Madin, I.P., 1990, Earthquake hazard geology maps of the Portland metropolitan area, Oregon: Oregon Department of Geology and Mineral Industries Open-File Report 0-90-2, scale 1:24,000, 22 p.

Snyder, D.T., 2008, Estimated Depth to Ground Water and Configuration of the Water Table in the Portland, Oregon Area: U.S. Geological Survey Scientific Investigations Report 2008–5059, 41 p., 3 plates.

Yeats, R.S., Graven, E.P., Werner, K.S., Goldfinger, C., and Popowski, T., 1996, Tectonics of the Willamette Valley, Oregon: in Assessing earthquake hazards and reducing risk in the Pacific Northwest, Vol. 1: U.S. Geological Survey Professional Paper 1560, P. 183-222, 5 plates, scale 1:100,000.

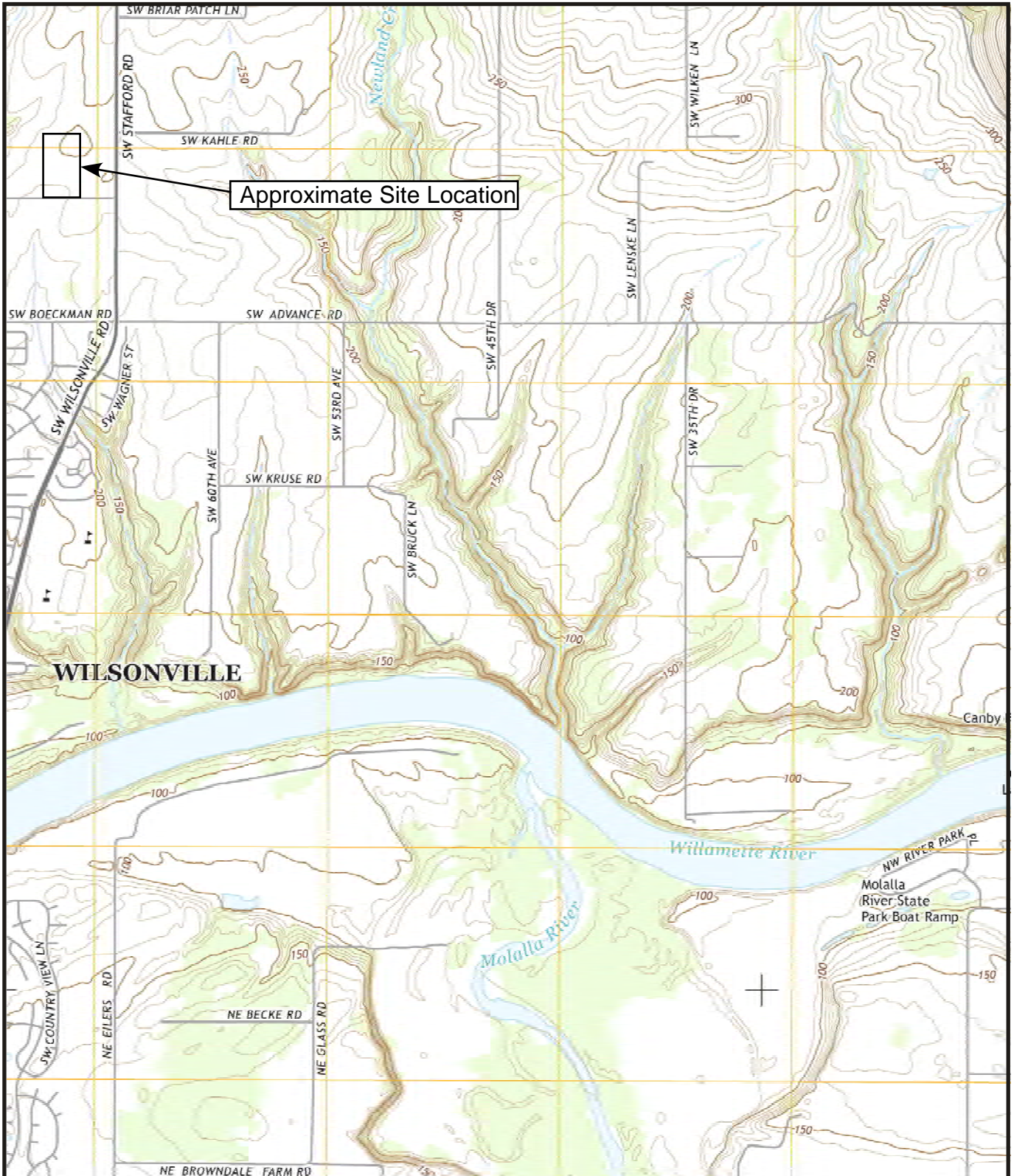

Project: Miller Property
Wilsonville, Oregon

Project No. 18-2338

FIGURE 1



**HARDMAN
GEOTECHNICAL
SERVICES INC.**

Practical, Cost-Effective Geotechnical Solutions

SITE PLAN



Legend



Approximate Site Location



Approximate Location of Hand Auger Boring

Base map provided by Google Earth

Project: Miller Property
Wilsonville, Oregon

Project No. 18-2338

FIGURE 2

HAND AUGER BORING LOG

Project: Frog Pond - Miller Properties
Wilsonville, Oregon

Project No. 18-2338

Boring No. HA- 1

Depth (ft)	Sample Interval	Sample Designation	Pocket Penetrometer (tons/ft ²)	Moisture Content (%)	Groundwater	Material Description
1						Soft, highly organic SILT (OH), dark brown, moist (Topsoil)
2						Medium stiff, silty CLAY (CL), greyish brown with orange and gray mottling, moist (Willamette Formation)
3						
4						
5	☒					Very stiff, clayey SILT (MH), light brown with orange and gray mottling, slightly moist (Willamette Formation)
6						
7						
8					▽	Slight seepage at about 8 feet
9						Boring terminated at 8 feet
10						
11						
12						
13						
14						
15						

HGSI HARDMAN
GEOTECHNICAL
SERVICES INC.
Practical Cost-Effective Geotechnical Solutions
10110 SW Nimbus Avenue, Suite B-5
Portland, Oregon 97223
(503) 530-8076

LEGEND

▽
Observed seepage
at time of excavation

☒
Sample Depth

Date Excavated: 7/16/18
Logged By: CSH

HAND AUGER BORING LOG

Project: Frog Pond - Miller Properties
Wilsonville, Oregon

Project No. 18-2338

Boring No. HA- 2

Depth (ft)	Sample Interval	Sample Designation	Pocket Penetrometer (tons/ft ²)	Moisture Content (%)	Groundwater	Material Description
1						Soft, highly organic (grass roots) SILT (OH), dark brown, moist (Topsoil)
2						Soft, clayey SILT (MH), light brown with orange and gray mottling, slightly moist (Till zone / disturbed native soil)
3						
4						
5						Very stiff, clayey SILT (MH), light brown with orange and gray mottling, slightly moist (Willamette Formation)
6						Boring terminated at 6 feet No groundwater encountered
7						
8						
9						
10						
11						
12						
13						
14						
15						

HGSI HARDMAN
GEOTECHNICAL
SERVICES INC.
Practical Cost-Effective Geotechnical Solutions
10110 SW Nimbus Avenue, Suite B-5
Portland, Oregon 97223
(503) 530-8076

LEGEND

Observed seepage
at time of excavation

Sample Depth

Date Excavated: 7/16/18
Logged By: CSH

HAND AUGER BORING LOG

Project: Frog Pond - Miller Properties
Wilsonville, Oregon

Project No. 18-2338

Boring No. HA- 3

Depth (ft)	Sample Interval	Sample Designation	Pocket Penetrometer (tons/ft ²)	Moisture Content (%)	Groundwater	Material Description
1						Soft, highly organic (grass roots) SILT(OL), light brown, dessicated
2						Very stiff, SILT (ML), light brown with orange and gray mottling, slightly moist (Willamette Formation)
3						Very stiff, clayey SILT (MH), light brown with orange and gray mottling, slightly moist (Willamette Formation)
4						
5						
6						
7						
8						Boring terminated at 8 feet No groundwater encountered
9						
10						
11						
12						
13						
14						
15						

HGSI HARDMAN
GEOTECHNICAL
SERVICES INC.
Practical Cost-Effective Geotechnical Solutions
10110 SW Nimbus Avenue, Suite B-5
Portland, Oregon 97223
(503) 530-8076

LEGEND

 Observed seepage at time of excavation

 Sample Depth

Date Excavated: 7/16/18
Logged By: CSH

HAND AUGER BORING LOG

Project: Frog Pond - Miller Properties
Wilsonville, Oregon

Project No. 18-2338

Boring No. HA- 4

Depth (ft)	Sample Interval	Sample Designation	Pocket Penetrometer (tons/ft ²)	Moisture Content (%)	Groundwater	Material Description
1						Soft, highly organic (grass roots) SILT(OL), light brown, dessicated
2						Very stiff, SILT (ML), light brown with orange and gray mottling, slightly moist (Willamette Formation)
3						
4						Very stiff, clayey SILT (MH), light brown with orange and gray mottling, moist (Willamette Formation)
5						
6	☒					Material moistening with depth
7						
8					▽	Slight seepage at 8 feet
9						Boring terminated at 8 feet
10						
11						
12						
13						
14						
15						

HGSI HARDMAN
GEOTECHNICAL
SERVICES INC.
Practical Cost-Effective Geotechnical Solutions
10110 SW Nimbus Avenue, Suite B-5
Portland, Oregon 97223
(503) 530-8076

LEGEND

▽
Observed seepage
at time of excavation

☒
Sample Depth

Date Excavated: 7/16/18
Logged By: CSH

HAND AUGER BORING LOG

Project: Frog Pond - Miller Properties
Wilsonville, Oregon

Project No. 18-2338

Boring No. HA- 5

Depth (ft)	Sample Interval	Sample Designation	Pocket Penetrometer (tons/ft ²)	Moisture Content (%)	Groundwater	Material Description
1						Soft, highly organic (grass roots) SILT(OL), light brown, dessicated
2						Very stiff, SILT (ML), light brown with orange and gray mottling, slightly moist (Willamette Formation)
3						Very stiff, clayey SILT (MH), light brown with orange and gray mottling, slightly moist
4						(Willamette Formation)
5						
6						
7						
8						Boring terminated at 8 feet No groundwater encountered
9						
10						
11						
12						
13						
14						
15						

HGSI HARDMAN
GEOTECHNICAL
SERVICES INC.
Practical Cost-Effective Geotechnical Solutions
10110 SW Nimbus Avenue, Suite B-5
Portland, Oregon 97223
(503) 530-8076

LEGEND

 Observed seepage at time of excavation

 Sample Depth

Date Excavated: 7/16/18
Logged By: CSH

HAND AUGER BORING LOG

Project: Frog Pond - Miller Properties
Wilsonville, Oregon

Project No. 18-2338

Boring No. HA- 6

Depth (ft)	Sample Interval	Sample Designation	Pocket Penetrometer (tons/ft ²)	Moisture Content (%)	Groundwater	Material Description
1						Soft, highly organic (grass roots) SILT(OL), light brown, dessicated
2						Very stiff, SILT (ML), light brown with orange and gray mottling, slightly moist (Willamette Formation)
3						
4						Very stiff, clayey SILT (MH), light brown with orange and gray mottling, slightly moist (Willamette Formation)
5						
6						Boring terminated at 6 feet No groundwater encountered
7						
8						
9						
10						
11						
12						
13						
14						
15						

HGSI HARDMAN
GEOTECHNICAL
SERVICES INC.
Practical Cost-Effective Geotechnical Solutions
10110 SW Nimbus Avenue, Suite B-5
Portland, Oregon 97223
(503) 530-8076

LEGEND

 Observed seepage at time of excavation

 Sample Depth

Date Excavated: 7/16/18
Logged By: CSH

ASCE 7 Hazards Report

Address:
No Address at This
Location

Standard: ASCE/SEI 7-16
Risk Category: II
Soil Class: D - Stiff Soil

Elevation: 244.8 ft (NAVD 88)
Latitude: 45.3234
Longitude: -122.7469

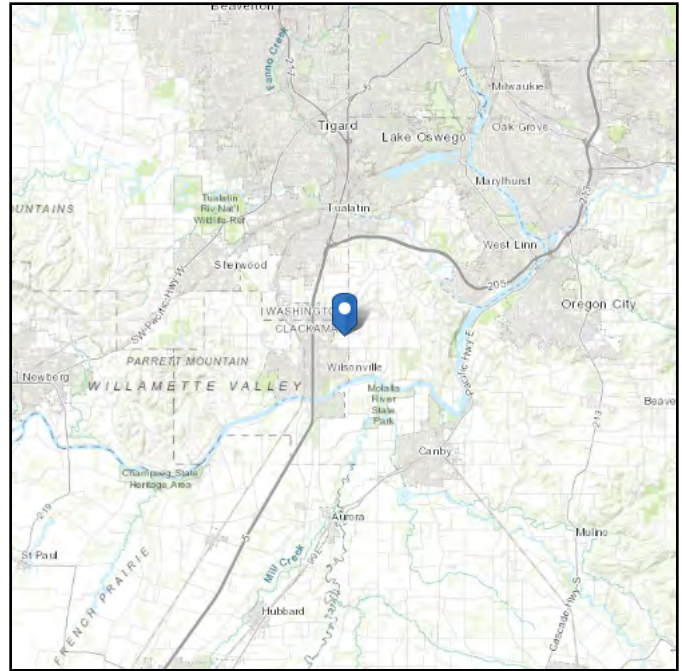
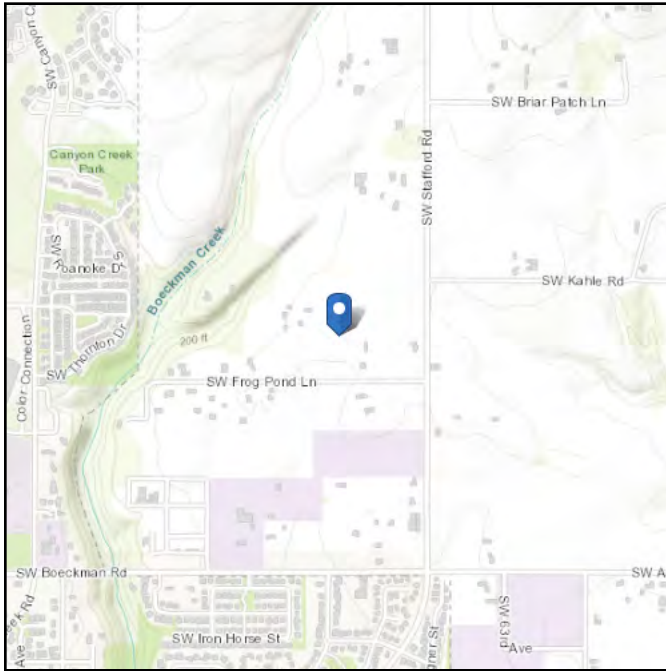

Seismic

Site Soil Class: D - Stiff Soil

Results:

S_s :	0.821	S_{D1} :	N/A
S_1 :	0.381	T_L :	16
F_a :	1.172	PGA :	0.373
F_v :	N/A	PGA _M :	0.458
S_{MS} :	0.962	F_{PGA} :	1.227
S_{M1} :	N/A	I_e :	1
S_{DS} :	0.641	C_v :	1.21

Ground motion hazard analysis may be required. See ASCE/SEI 7-16 Section 11.4.8.

Data Accessed: Fri Dec 10 2021

Date Source: [USGS Seismic Design Maps](#)

The ASCE 7 Hazard Tool is provided for your convenience, for informational purposes only, and is provided “as is” and without warranties of any kind. The location data included herein has been obtained from information developed, produced, and maintained by third party providers; or has been extrapolated from maps incorporated in the ASCE 7 standard. While ASCE has made every effort to use data obtained from reliable sources or methodologies, ASCE does not make any representations or warranties as to the accuracy, completeness, reliability, currency, or quality of any data provided herein. Any third-party links provided by this Tool should not be construed as an endorsement, affiliation, relationship, or sponsorship of such third-party content by or from ASCE.

ASCE does not intend, nor should anyone interpret, the results provided by this Tool to replace the sound judgment of a competent professional, having knowledge and experience in the appropriate field(s) of practice, nor to substitute for the standard of care required of such professionals in interpreting and applying the contents of this Tool or the ASCE 7 standard.

In using this Tool, you expressly assume all risks associated with your use. Under no circumstances shall ASCE or its officers, directors, employees, members, affiliates, or agents be liable to you or any other person for any direct, indirect, special, incidental, or consequential damages arising from or related to your use of, or reliance on, the Tool or any information obtained therein. To the fullest extent permitted by law, you agree to release and hold harmless ASCE from any and all liability of any nature arising out of or resulting from any use of data provided by the ASCE 7 Hazard Tool.

Appendix G

Stafford Meadows PUD recorded CC&Rs and Bylaws



AFTER RECORDING, RETURN TO:

52p

Michelle D. Da Rosa LLC
Attorney at Law
205 SE Spokane Street, Suite 300
Portland, OR 97202

Clackamas County Official Records
Sherry Hall, County Clerk

2019-002161



\$358.00

02201725201900021610520524

01/15/2019 09:08:53 AM

PD-COV Cnt=3 Stn=2 COUNTER3
\$260.00 \$10.00 \$16.00 \$62.00 \$10.00

**DECLARATION OF PROTECTIVE COVENANTS, CONDITIONS,
RESTRICTIONS AND EASEMENTS
FOR STAFFORD MEADOWS**

WEST HILLS LAND DEVELOPMENT LLC

Declarant

TABLE OF CONTENTS

	Page
ARTICLE 1 DEFINITIONS	1
1.1 “Additional Property”	1
1.2 “Architectural Review Committee” or “the Committee”	1
1.3 “Assessments”	1
1.4 “Association”	1
1.5 “Board of Directors” or “the Board”	2
1.6 “Bylaws”	2
1.7 “City of Wilsonville Development Agreements”	2
1.8 “Common Areas”	2
1.9 “Common Easement Areas”	2
1.10 “Common Maintenance Areas”	2
1.11 “Declarant”	2
1.12 “Design Guidelines”	3
1.13 “Emergency Assessments”	3
1.14 “Front Yard”	3
1.15 “General Assessments”	3
1.16 “General Plan of Development”	3
1.17 “Home”	3
1.18 “Improvement”	3
1.19 “Individual Assessments”	3
1.20 “Initial Property”	3
1.21 “Limited Common Areas”	3
1.22 “Limited Common Area Assessments”	3
1.23 “Limited Common Easement Areas”	3
1.24 “Lot”	3
1.25 “Mortgage”	3
1.26 “Occupant”	4
1.27 “Operations Fund”	4

1.28	“Owner”	4
1.29	“Person”	4
1.30	“Plat”	4
1.31	“Public Areas”	4
1.32	“Reserve Fund”	4
1.33	“Rules and Regulations”	4
1.34	“Sold”	4
1.35	“Special Assessments”	4
1.36	“Stafford Meadows”	4
1.37	“The Property”	4
1.38	“This Declaration”	4
1.39	“Turnover Meeting”	5
1.40	“Working Fund Assessments”	5
ARTICLE 2 PROPERTY SUBJECT TO THIS DECLARATION.....		5
2.1	Initial Property.	5
2.2	Annexation of Additional Property.	5
2.3	Improvements.	6
2.4	Withdrawal of Property.....	6
2.5	Dedications.....	6
2.6	Conversion of Lots to Common Areas.....	6
2.7	Subdivisions.....	7
2.8	Consolidations.....	7
ARTICLE 3 LAND CLASSIFICATIONS		7
3.1	Land Classifications Within Initial Property.	7
3.2	Conversion of Lots to Common Areas.....	8
3.3	Subdivisions.....	8
3.4	Consolidations.....	8
ARTICLE 4 PROPERTY RIGHTS IN COMMON AREAS		8
4.1	Owners’ Easements of Enjoyment.	8
4.2	Title to Common Areas.	9
4.3	Extent of Owners’ Rights.	9
(a)	Association Easements.....	9

(b)	Public and Utility Easements.....	9
(c)	Use of the Common Areas.....	10
(d)	Alienation of the Common Areas.....	10
(e)	Leases, Easements, Rights-of-Way, Licenses and Similar Interests and Vacations of Roadways.....	10
(f)	Limitations on Use.....	10
4.4	Delegation of Use.....	11
4.5	Easements Reserved by Declarant.....	11
4.6	Easement to Serve Other Property.....	12
4.7	Limited Common Areas.....	12
ARTICLE 5 PROPERTY RIGHTS IN LOTS		12
5.1	Use and Occupancy.....	12
5.2	Easements Reserved.....	12
(a)	Adjacent Common Maintenance Area.....	12
(b)	Utility Easements.....	13
(c)	Construction on Adjoining Lot.....	13
(d)	Utility Inspection and Repairs.....	13
(e)	Easements for Encroachments.....	13
(f)	Easements for Maintenance, Emergency and Enforcement.....	13
(g)	Future Easements.....	14
ARTICLE 6 GENERAL USE RESTRICTIONS		14
6.1	Structures Permitted.....	14
6.2	Residential Use.....	14
6.3	Offensive or Unlawful Activities.....	14
6.4	Animals.....	15
6.5	Maintenance of Structures.....	15
6.6	Landscape Installation.....	15
6.7	Maintenance of Landscaping.....	15
6.8	Boundary Fences.....	16
6.9	Fences, Hedges and Walls.....	16
6.10	Pest and Weed Control.....	16
6.11	Parking.....	16

6.12	Vehicles in Disrepair.....	16
6.13	Signs.....	16
6.14	Rubbish, Trash and Outside Storage.....	17
6.15	Construction.....	17
6.16	Temporary Structures.....	17
6.17	Recreational Equipment.....	17
6.18	Service Facilities.....	18
6.19	Antennas and Satellite Dishes.....	18
6.20	Exterior Lighting or Noisemaking Devices.....	18
6.21	Subdividing or Partitioning Lots.....	18
6.22	Grades, Slopes and Drainage.....	18
6.23	Garages.....	18
6.24	Windows, Decks, Porches and Outside Walls.....	19
6.25	Air Conditioning Units.....	19
6.26	Firearms and Fireworks.....	19
6.27	Nonbiodegradable Substances.....	19
6.28	Leasing and Rental of Homes.....	19
6.29	Rules and Regulations.....	19
ARTICLE 7 ARCHITECTURAL REVIEW COMMITTEE.....		19
7.1	Architectural Review.....	19
7.2	Committee Decision.....	20
7.3	Committee Discretion.....	20
7.4	Design Guidelines.....	20
	(a) Adoption of Design Guidelines.....	20
	(b) Publication of Design Guidelines.....	21
	(c) Amendment of Design Guidelines.....	21
7.5	Membership: Appointment and Removal.....	21
7.6	Majority Action.....	22
7.7	Liability.....	22
7.8	Nonwaiver.....	22
7.9	Appeal.....	22
7.10	Effective Period of Consent.....	22

7.11	Estoppel Certificate.....	22
7.12	Enforcement.....	22
ARTICLE 8 ASSOCIATION.....		23
8.1	Organization.....	23
8.2	Membership.....	23
8.3	Voting Rights.....	23
8.4	General Powers and Obligations.....	24
8.5	Specific Powers and Duties.....	24
(a)	Maintenance and Services.....	24
(b)	Insurance.....	24
(c)	Rulemaking.....	24
(d)	Assessments.....	24
(e)	Enforcement.....	24
(f)	Employment of Agents, Advisers and Contractors.....	25
(g)	Borrow Money.....	25
(h)	Acquire and Hold Title to Property.....	25
(i)	Transfers, Dedications, Encumbrances and Easements.....	25
(j)	Create Classes of Service and Make Appropriate Charges.....	25
(k)	Restoring Damaged Improvements.....	25
(l)	Security.....	26
(m)	Services.....	26
(n)	Implied Rights and Obligations.....	26
8.6	Liability.....	26
8.7	Interim Board; Turnover Meeting.....	26
8.8	Contracts Entered into by Declarant or Before Turnover Meeting.....	27
8.9	Bylaws.....	27
ARTICLE 9 MAINTENANCE.....		27
9.1	Common Maintenance Areas.....	27
9.2	Maintenance and Lighting of Common Maintenance Areas.....	27
9.3	Maintenance of Utilities.....	28
9.4	Owner's Responsibility.....	28
9.5	Damage Liability.....	28

9.6	Maintenance Plan	29
ARTICLE 10 ASSESSMENTS		29
10.1	Purpose of Assessments.	29
10.2	When Lots Become Subject to Assessment.	29
10.3	Allocation of Assessments.	29
10.4	Type of Assessments.....	30
(a)	General Assessments.	30
(b)	Special Assessments.....	30
(c)	Emergency Assessments.	30
(d)	Limited Common Area Assessments.....	30
(e)	Individual Assessments.	31
(f)	Working Fund Assessments.....	31
10.5	Assessment of Additional Property.....	31
10.6	Operations Fund.	31
10.7	Reserve Fund.....	32
(a)	Establishment of Account.	32
(b)	Funding of Reserve Fund.	32
(c)	Reserve Studies.	32
(d)	Use of Reserve Fund.....	33
10.8	Declarant's Subsidy.....	33
10.9	Commencement of Assessment Obligation; Time of Payment.	33
10.10	Payment of Assessments.	33
10.11	Creation of Lien and Personal Obligation of Assessments.	33
10.12	Voluntary Conveyance.	33
10.13	No Waiver.....	34
10.14	No Option to Exempt.....	34
10.15	Certificate.....	34
ARTICLE 11 ENFORCEMENT		34
11.1	Violation of General Protective Covenants.	34
11.2	Default in Payment of Assessments; Enforcement of Lien.	35
11.3	Interest, Late Charges and Expenses.....	35
11.4	Costs and Attorneys' Fees.	36

11.5	Assignment of Rents.....	36
11.6	Nonexclusiveness and Accumulation of Remedies.....	36
11.7	Enforcement by Clackamas County.....	36
ARTICLE 12 DISPUTE RESOLUTION		37
12.1	Mediation.....	37
12.2	Arbitration.....	37
12.3	Selection of Arbitrator.....	38
12.4	Consolidated Arbitration.....	38
12.5	Discovery.....	38
12.6	Evidence.....	38
12.7	Excluded Matters.....	38
12.8	Costs and Attorneys' Fees.....	38
12.9	Survival.....	39
ARTICLE 13 MORTGAGEES.....		39
13.1	Subordination of Lien to Mortgages.....	39
13.2	Reimbursement of First Mortgagees.....	39
13.3	Notification of First Mortgagee.....	39
13.4	Notice to Association.....	39
ARTICLE 14 AMENDMENT AND REPEAL		40
14.1	How Proposed.....	40
14.2	Approval Required.....	40
14.3	Recordation.....	40
14.4	Regulatory Amendments.....	40
ARTICLE 15 MISCELLANEOUS PROVISIONS		41
15.1	No Implied Obligations.....	41
15.2	Right to Approve Additional Covenants.....	41
15.3	Notice of Sale or Transfer of Title.....	41
15.4	Exclusive Rights to Use Name of Development.....	41
15.5	Lessees and Other Invitees.....	41
15.6	Nonwaiver.....	41
15.7	Construction and Severability.....	41
15.8	Terminology and Captions.....	42

15.9	Notices.....	42
15.10	Private Agreement.....	42

**DECLARATION OF PROTECTIVE COVENANTS,
CONDITIONS, RESTRICTIONS AND EASEMENTS
FOR STAFFORD MEADOWS**

THIS DECLARATION is made this 15 day of January, 2019 by WEST HILLS LAND DEVELOPMENT LLC, an Oregon limited liability company ("Declarant").

RECITALS

A. Declarant has recorded the plat of "Stafford Meadows" in the plat records of Clackamas County, Oregon as Plat No. 4558. Declarant is the only owner of the land so platted.

B. Declarant desires to subject the Lots and Tracts described in Section 2.1 to the conditions, restrictions and charges set forth in this instrument for the benefit of such property, and its present and subsequent owners, and to establish such property under the Oregon Planned Community Act, ORS 94.550 to 94.783, as the first phase of a Class I planned development to be known as Stafford Meadows.

NOW, THEREFORE, Declarant hereby declares that the property described in Section 2.1 will be held, sold and conveyed subject to the following easements, covenants, restrictions and charges, which run with such property and are binding on all parties having or acquiring any right, title, or interest in such property or any part thereof, unless otherwise provided herein, and inure to the benefit of all such persons.

Article 1

DEFINITIONS

As used in this Declaration, the terms set forth below have the following meanings:

1.1 "**Additional Property**" means any land, whether or not owned by Declarant, that is made subject to this Declaration as provided in Section 2.2.

1.2 "**Architectural Review Committee**" or "**the Committee**" means the committee appointed pursuant to Article 7.

1.3 "**Assessments**" means all assessments and other charges, fines and fees imposed by the Association on an Owner in accordance with this Declaration, the Bylaws of the Association, or the provisions of the Oregon Planned Community Act, including, without limitation, General Assessments, Special Assessments, Emergency Assessments, Limited Common Area Assessments, Working Fund Assessments and Individual Assessments as described in Article 10.

1.4 "**Association**" means the nonprofit corporation formed to serve as the Owners association as provided in Article 8, and its successors and assigns.

1.5 **“Board of Directors” or “the Board”** means the duly appointed or elected board of directors of the Association, which is invested with the authority to operate the Association and to appoint the officers of the Association. Prior to the Turnover Meeting, Declarant will appoint the Board of Directors. After the Turnover Meeting, the Board will be elected by the Owners.

1.6 **“Bylaws”** means the duly adopted bylaws of the Association as the same may hereafter be amended or replaced.

1.7 **“City of Wilsonville Development Agreements”** mean the following agreements between Declarant and the City of Wilsonville dated effective the same date as this Declaration and recorded in the Records of Clackamas County, Oregon:

-Sanitary Sewer Pipeline Easement Agreement (Tracts “B” and “C”, Plat of “Stafford Meadows”);

-Stormwater Pipeline Easement Agreement (Tracts “B”, “C”, and “D”, Portions of Tracts “F” and “G”, Portion of Lot 11, Plat of “Stafford Meadows”);

-Conservation Easement, which affects a portion of Tract F as legally described in the exhibits in the Conservation Easement);

-Storm Drainage Easement Agreement (Tract “G”, Plat of “Stafford Meadows”);

-Water Pipeline Easement Agreement (Tract “I”, Portion of Tract “H”, Plat of “Stafford Meadows”);

-Public Access Easement Agreement (Tracts “A”, “B”, “C”, “D”, “E”, “H”, “I”, AND “J”, Portions of Lots 1-6, Plat of “Stafford Meadows”).

1.8 **“Common Areas”** means those lots or tracts designated as such on any plat of the Property, or in this Declaration or any declaration annexing Additional Property to Stafford Meadows, including any Improvements thereon, and also includes Limited Common Areas, Common Easement Areas, Limited Common Easement Areas, and any Lots converted to Common Areas as provided in Section 3.2.

1.9 **“Common Easement Areas”** means the easements established for the benefit of all property within Stafford Meadows pursuant to this Declaration or any plat or declaration annexing Additional Property to Stafford Meadows.

1.10 **“Common Maintenance Areas”** means the Common Areas and any other areas designated as such in Section 9.1 of this Declaration or in any declaration annexing Additional Property to Stafford Meadows as being maintained by the Association.

1.11 **“Declarant”** means West Hills Land Development LLC, and its successors and assigns if such successor or assignee should acquire Declarant’s interest in the remainder of the Property, or less than all of such property if a recorded instrument executed by Declarant assigns to the transferee all of Declarant’s rights under this Declaration, and any member or affiliate of West Hills Land Development LLC. Any such successor declarant will succeed to all of the rights and

obligations of the Declarant under this Declaration, including, without limitation, the obligation to complete any Improvements required by City of Wilsonville as part of its subdivision approval.

1.12 "**Design Guidelines**" means the guidelines adopted from time to time by the Architectural Review Committee pursuant to Article 7.

1.13 "**Emergency Assessments**" means the Assessments described in Section 10.4(c).

1.14 "**Front Yard**" means the front yards and side yards of Lots, which are not enclosed by a fence and street frontage planter strips for all Lots, street trees and entry monuments, if any.

1.15 "**General Assessments**" means the Assessments described in Section 10.4(a).

1.16 "**General Plan of Development**" means Declarant's general plan of development of the Property as approved by Clackamas County, as the same may be amended from time to time.

1.17 "**Home**" means a building or a portion of a building located upon a Lot within the Property and designated for separate residential occupancy together with any permitted accessory dwelling unit.

1.18 "**Improvement**" means every structure or improvement of any kind, including, but not limited to, a fence, wall, driveway, swimming pool, storage shelter, mailbox and newspaper receptacle, landscaping and any other product of construction efforts on or in respect to the Property.

1.19 "**Individual Assessments**" means the Assessments described in Section 10.4(d).

1.20 "**Initial Property**" means the real property referred to in Section 2.1.

1.21 "**Limited Common Areas**" means those Common Areas established for the exclusive use or enjoyment of certain Lots as designated in this Declaration or in any declaration annexing property to Stafford Meadows including Limited Common Easement Areas.

1.22 "**Limited Common Area Assessments**" means the Assessments described in Section 10.4(d).

1.23 "**Limited Common Easement Areas**" means those Limited Common Area easements established for the exclusive use or enjoyment of certain Lots as designated in this Declaration or in the Plat or any declaration annexing property to Stafford Meadows.

1.24 "**Lot**" means a platted or partitioned lot within the Property, with the exception of any lot marked on the Plat as being common or open space or so designated in this Declaration or the declaration annexing such property to Stafford Meadows. Lots do not include Common Areas or Public Areas.

1.25 "**Mortgage**" means a mortgage or a trust deed, "**Mortgagee**" means a mortgagee or a beneficiary of a trust deed, and "**Mortgagor**" means a mortgagor or a grantor of a trust deed.

1.26 “**Occupant**” means the occupant of a Home who is the Owner, lessee or any other Person authorized by the Owner to occupy the premises.

1.27 “**Operations Fund**” means the fund described in Section 10.6.

1.28 “**Owner**” means the Person or Persons, including Declarant, owning any Lot in the Property, but does not include a tenant or holder of a leasehold interest or a contract vendor or other Person holding only a security interest in a Lot. If a Lot is Sold under a recorded real estate installment sale contract, the purchaser (rather than the seller) will be considered the Owner unless the contract specifically provides to the contrary. If a Lot is subject to a written lease with a term in excess of one year and the lease specifically so provides, then upon filing a copy of the lease with the Board of Directors, the lessee (rather than the fee owner) will be considered the Owner during the term of the lease for the purpose of exercising any rights related to such Lot under this Declaration. The rights, obligations and other status of being an Owner commence upon acquisition of the ownership of a Lot and terminate upon disposition of such ownership, but termination of ownership does not discharge an Owner from obligations incurred prior to termination.

1.29 “**Person**” means a human being, a corporation, partnership, limited liability company, trustee or other legal entity.

1.30 “**Plat**” means the plat of Stafford Meadows recorded in the plat records of Clackamas County, Oregon as Document No. _____ and any annexation plat, as the same may be amended.

1.31 “**Public Areas**” means areas or easement areas dedicated to the public or established for public use in any plat of the Property, or so designated in this Declaration or the declaration annexing such property to Stafford Meadows.

1.32 “**Reserve Fund**” means the fund described in Section 10.7.

1.33 “**Rules and Regulations**” means those policies, procedures, rules and regulations adopted by the Association pursuant to the authority granted in this Declaration, as the same may be amended from time to time.

1.34 “**Sold**” means that legal title has been conveyed or that a contract of sale has been executed and recorded under which the purchaser has obtained the right to possession.

1.35 “**Special Assessments**” means the Assessments described in Section 10.4(b)

1.36 “**Stafford Meadows**” means the Initial Property and any Additional Property annexed to this Declaration.

1.37 “**The Property**” means Stafford Meadows.

1.38 “**This Declaration**” means all of the easements, covenants, restrictions and charges set forth in this instrument, together with any rules or regulations promulgated hereunder, as the same may be amended or supplemented from time to time in accordance with the provisions hereof, including the provisions of any supplemental declaration annexing property to Stafford Meadows.

1.39 “**Turnover Meeting**” means the meeting called by Declarant pursuant to Section 8.7, at which Declarant will turn over administrative responsibility for the Property to the Association.

1.40 “**Working Fund Assessments**” means the Assessments described in Section 10.4(f).

Article 2

PROPERTY SUBJECT TO THIS DECLARATION

2.1 **Initial Property.** Declarant hereby declares that all of the real property located in the City of Wilsonville described below is owned and will be owned, conveyed, hypothecated, encumbered, used, occupied and improved subject to this Declaration:

All real property within that certain plat entitled “**Stafford Meadows,**” filed in the plat records of Clackamas County, Oregon, as Document No. 2019-002153, except Lot 24 and Tracts A, K and L.

2.2 **Annexation of Additional Property.** Declarant may from time to time and in its sole discretion annex to Stafford Meadows as “Additional Property” any real property now or hereafter acquired by it and may also from time to time and in its sole discretion permit other holders of real property to annex the real property owned by them to Stafford Meadows. The annexation of such Additional Property is accomplished as follows:

(a) The Owner or Owners of such real property will record a declaration that is executed by or bear the approval of Declarant and will, among other things, describe the real property to be annexed; establish land classifications for the Additional Property; establish any additional limitations, uses, restrictions, covenants and conditions that are intended to be applicable to such Additional Property; and declare that such property is held and will be held, conveyed, hypothecated, encumbered, used, occupied and improved subject to this Declaration.

(b) The Additional Property described in any such annexation thereby becomes a part of Stafford Meadows and subject to this Declaration, and the Declarant and the Association will have and accept and exercise administration of this Declaration with respect to such Additional Property.

(c) Notwithstanding any provision apparently to the contrary, a declaration with respect to any Additional Property may:

(1) modify or exclude any then-existing restrictions and establish such new land classifications and such limitations, uses, restrictions, covenants and conditions with respect to such Additional Property as Declarant may deem to be appropriate for the development of the Additional Property; and

(2) with respect to existing land classifications, modify or exclude any then-existing restrictions and establish additional or different limitations, uses, restrictions, covenants and conditions with respect to such property as Declarant may deem to be appropriate for the development of such Additional Property.

(d) There is no limitation on the number of Lots or Homes that Declarant may create or annex to Stafford Meadows except as may be established by applicable ordinances of Clackamas County. Similarly, there is no limitation on the right of Declarant to annex common property, except as may be established by Clackamas County.

(e) Declarant does not agree to build any specific future Improvement but does not choose to limit Declarant's right to add additional Improvements.

(f) Nothing in this Declaration establishes any duty or obligation on Declarant to annex any property to this Declaration, and no owner of property excluded from this Declaration has any right to have such property annexed to this Declaration or Stafford Meadows.

(g) Upon annexation to Stafford Meadows, additional Lots so annexed will be entitled to voting rights as set forth in Section 8.3.

(h) The formula to be used for reallocating the common expenses if additional Lots are annexed and the manner of reapportioning the common expenses if additional Lots are annexed during a fiscal year are set forth in Section 10.5.

2.3 **Improvements.** Declarant does not agree to build any Improvements on the Property other than as required by City of Wilsonville, but may elect, at Declarant's option, to build additional Improvements.

2.4 **Withdrawal of Property.** Property may be withdrawn from Stafford Meadows only by duly adopted amendment to this Declaration, except that Declarant may withdraw all or a portion of the Initial Property or any Additional Property annexed pursuant to a declaration described in Section 2.2 at any time prior to the sale of the first Lot in the plat of the Initial Property or, in the case of Additional Property, prior to the sale of the first Lot in the property annexed by the supplemental declaration, subject to the prior approval of City of Wilsonville. Such withdrawal will be by a declaration executed by Declarant and recorded in the deed records of Clackamas County, Oregon. If a portion of the Property is withdrawn, all voting rights otherwise allocated to Lots being withdrawn will be eliminated, and the common expenses will be reallocated among the remaining Lots.

2.5 **Dedications.** Declarant reserves the right to dedicate any portions of the Property then owned by Declarant to any governmental authority, quasi-governmental entity or entity qualifying under Section 501(c)(3) of the Internal Revenue Code or similar provisions, from time to time, for such purposes as Declarant may deem to be appropriate, including, without limitation, for utility stations, equipment, fixtures and lines; streets and roads; sidewalks; trails; open space; recreational facilities; schools; fire, police, security, medical and similar services; and such other purposes as Declarant and such governmental authority or quasi-governmental entity determine to be appropriate from time to time. Any consideration received by Declarant as a result of such dedication or by reason of any condemnation or any conveyance in lieu of condemnation will belong solely to Declarant.

2.6 **Conversion of Lots to Common Areas.** Declarant may elect to build common facilities on one or more Lots and designate such Lots, or any portion thereof, as Common Areas by a supplemental declaration recorded in the deed records of Clackamas County, Oregon. The supplemental declaration must be executed by Declarant. Additionally, Declarant reserves the right over the Common Areas (excluding the Common Easement Areas) to make boundary line

adjustments between any Lot (before the Lot has been sold to someone other than the Declarant or a successor declarant) and an adjacent Common Area by a supplemental declaration and plat recorded in the deed records of Clackamas County, Oregon, notwithstanding that such an adjustment may convert a Lot or a portion thereof to Common Area, or a Common Area, or portion thereof, into a Lot or portion of a Lot. This reserved conversion right will expire upon turnover of the Association to the members by the Declarant as provided for in the Bylaws.

2.7 **Subdivisions.** Declarant reserves the right to subdivide any Lots in the Additional Property then owned by it upon receiving all required approvals from the applicable governing authority. If any two or more Lots are so subdivided or subject to condominium ownership, they will be deemed separate Lots for the purposes of allocating assessments under the Declaration. No other Owner of any Lot in the Additional Property may subdivide any Lot without the prior written approval of Declarant prior to the Turnover Meeting and thereafter by the Architectural Review Committee, which consent may be granted or denied at the sole discretion of Declarant or the Committee, as applicable.

2.8 **Consolidations.** Declarant has the right to consolidate any two or more Lots in the Additional Property then owned by it upon receipt of any required approvals from the applicable governing authority. No other Owner may consolidate any Lots without the prior written approval of Declarant before the Turnover Meeting and thereafter by the Architectural Review Committee, which may be granted or denied at the sole discretion of Declarant or the Committee, as applicable. An approved consolidation will be effected by the recording of a supplemental declaration stating that the affected Lots are consolidated, which declaration must be executed by the Owner(s) of the affected Lots and by the chairperson of the Association. Once so consolidated, the consolidated Lot may not thereafter be partitioned, nor may the consolidation be revoked except as provided in Section 2.7 above. Any Lots consolidated pursuant to this section will be considered one Lot thereafter for the purposes of the Declaration, including voting rights and allocation of Assessments.

Article 3

LAND CLASSIFICATIONS

3.1 **Land Classifications Within Initial Property.** All land within the Initial Property is included in one or another of the following classifications:

(a) Lots, which consist of Lots 1 through 23 and Lots 25 through 44, inclusive, of the plat of the Initial Property.

(b) Common Areas, including the areas marked as Tracts D, E, F, G, H, I, and J, on the plat of the Initial Property, plus the Limited Common Areas, Common Easement Areas, and Limited Common Easement Areas, all of which are to be owned and maintained by the Association pursuant to the terms and conditions of this Declaration. Tract D is a pedestrian, bicycle, and emergency vehicular access area; Tract F is a natural resource area; Tract G is a stormwater treatment area subject to an easement in favor of the City of Wilsonville; Tracts E, H, I and J are open space areas that are subject to public pedestrian and bicycle access easements, with E and H being landscape buffers along S.W. Boeckman Road.

(c) Common Easement Areas, inclusive, public pedestrian access easements, public utility easements, storm drainage easements, clean water service and storm facility easement areas, sight distance easements, wall maintenance easements in favor of the Association, and any other easements established on the plat of the Initial Property or in any recorded document for entrance signage, monuments, or landscaping over Lots.

(d) Tract B is a Limited Common Area for ingress and egress over a shared driveway to and from Lots 1 and 6, which is subject to a wall maintenance; Tract C is a Limited Common Area for ingress and egress over a shared driveway to and from Lots 2, 3, 4, and 5.

(e) There are no Limited Common Easement Areas in the Initial Property.

3.2 **Conversion of Lots to Common Areas.** Declarant may elect to build common facilities on one or more Lots and designate such Lots as Common Areas by a declaration recorded in the deed records of Clackamas County, Oregon. Such declaration must be executed by Declarant as Owner of the Lots.

3.3 **Subdivisions.** Declarant reserves the right to subdivide any Lots then owned by it upon receiving all required approvals from City of Wilsonville. If a Lot or Lots are so subdivided, the new lots will be deemed separate Lots for the purposes of allocating Assessments under this Declaration. No other Owner of any Lot in the Property may subdivide any Lot without the prior written approval of the Declarant prior to the Turnover Meeting, and thereafter, by the Architectural Review Committee, which consent may be granted or denied at the sole discretion of the Declarant or the Committee, as applicable.

3.4 **Consolidations.** Declarant has the right to consolidate any two or more Lots then owned by it upon receipt of any required approvals from City of Wilsonville. No other Owner may consolidate any Lots without the prior written approval of the Declarant prior to the Turnover Meeting and thereafter by the Architectural Review Committee, which may be granted or denied at the sole discretion of the Declarant or Committee, as applicable. An approved consolidation will be effected by the recording of a supplemental declaration stating that the affected Lots are consolidated, which declaration must be executed by the Owner(s) of the affected Lots and by the president of the Association. Once so consolidated, the consolidated Lot may not thereafter be partitioned, nor may the consolidation be revoked except as provided in Section 3.3. Any Lots consolidated pursuant to this section will be considered one Lot thereafter for the purposes of this Declaration, including voting rights and allocation of Assessments.

Article 4

PROPERTY RIGHTS IN COMMON AREAS

4.1 **Owners' Easements of Enjoyment.** Subject to the provisions of this Article 4, every Owner and his or her invitees have a right and easement of enjoyment in and to the Common Areas, which easement is appurtenant to and passes with the title to every Lot. The use of the Limited Common Easement Areas, however, are limited to the Owners and invitees of the Lots designated in the declaration establishing the Limited Common Easement Area.

4.2 **Title to Common Areas.** Except for portions dedicated to the public or any governmental authority and otherwise provided in this Section 4.2, title to the Common Areas, except the Common Easement Areas and Limited Common Easement Areas, will be conveyed to the Association by Declarant AS IS, but free and clear of monetary liens, on or before the Turnover Meeting. The Association, upon such conveyance, will assume all obligations to maintain, insure, and otherwise assume the obligations of the Declarant in respect of the Common Areas set forth in this Agreement or the Plat or any agreement entered by Declarant with City of Wilsonville in respect of such tracts. Title to Common Easement Areas and Limited Common Easement Areas, if any, subject to the easements set forth in this Declaration or the supplemental declaration creating such areas, rests in the Owners of the respective Lots within which such areas are located, or to the public if part of dedicated street rights-of-way.

4.3 **Extent of Owners' Rights.** The rights and easements of enjoyment in the Common Areas created hereby are subject to the following and to all other provisions of this Declaration:

(a) **Association Easements.** Declarant grants to the Association for the benefit of the Association and all Owners of Lots within the Property the following easements over, under and upon the Common Maintenance Areas:

(1) An easement for underground installation and maintenance of power, gas, electric, water and other utility and communication lines and services installed by Declarant or with the approval of the Board of Directors of the Association and any such easement shown on any plat of the Property.

(2) An easement for construction, maintenance, repair, and use of such areas, including any common facilities on the Common Area tracts.

(3) An easement for access for regular upkeep, maintenance, modification and replacement of the Front Yard landscaping and related irrigation equipment, including drainage systems, if any, and for making emergency repairs to the landscaping and related equipment and settings in the Front Yards of the Lots necessary for the public safety or to prevent damage to the Common Maintenance Areas or to another Lot, or to enforce this Declaration or the Rules and Regulations, or with the approval of the Board of Directors of the Association; and notwithstanding that such areas of Lots are not regular Common Maintenance Areas, an easement for access to unfenced yard landscaping and irrigation controllers on Lots to enforce this Declaration or the Rules and Regulations, including but not limited to standards for Lot maintenance thereunder.

(4) An easement for the purpose of making repairs to any existing structures on Common Areas.

(b) **Public and Utility Easements.**

The Common Areas are subject to the public and utility easements established the Plat. In addition, the public is hereby granted access easements over all sidewalks, pedestrian accesses and trails in the Common Areas within the Property as designated on the Plat. In addition, Declarant or the Association may (and, to the extent required by law will) grant or assign such easements to municipalities or other utilities performing utility services and to communication

companies, and the Association may grant free access thereon to police, fire and other public officials, and to employees of utility companies and communications companies serving the Property.

(c) **Use of the Common Areas.** The Common Areas will be used for the purposes set forth in any plat of the Property; Common Area tracts identified on any plat of the Property may not be partitioned or otherwise divided into parcels for residential use; and, no private structure of any type will be constructed on the Common Areas. Except as otherwise provided in this Declaration, the Common Areas are reserved for the use and enjoyment of all Owners. No private use may be made of the Common Areas except as otherwise provided in this Declaration. No Owner may place or cause to be placed on the Common Areas any trash, structure, equipment, furniture, package, or object of any kind. Nothing in this Declaration prevents the placing of a sign or signs upon the Common Areas by Declarant or the Association identifying the Property or identifying pathways or items of interest, signs restricting certain uses, or warning, traffic or directional signs, provided that such signs are approved by the Architectural Review Committee and comply with any applicable sign ordinances. The Board of Directors has authority to abate any trespass or encroachment upon the Common Areas at any time, by any reasonable means and with or without having to bring legal proceedings. A declaration annexing Additional Property may provide that the Owners of such Additional Property do not have the right to use a particular Common Area or facility located on such Common Area, in which event such Common Area will automatically become a "Limited Common Area" assigned to the Lots that have access thereto.

(d) **Alienation of the Common Areas.** The Association may not by act or omission seek to abandon, partition, subdivide, encumber as security for a debt, sell, transfer or convey the Common Areas owned directly or indirectly by the Association for the benefit of the Lots unless the holders of at least 80 percent of the Class A voting rights and the Class B Member (as defined in Section 8.3), if any, have given their prior written approval and unless approved by City of Wilsonville. Such approvals will not be required for dedications under Section 2.5. The Association, upon approval in writing of at least two-thirds of the Class A voting rights and the Class B Member, if any, and if approved by order or resolution of City of Wilsonville, may dedicate or convey any portion of the Common Areas to a park district or other public body. Any sale, transfer, conveyance or encumbrance permitted by this Declaration may provide that the Common Area may be released from any restrictions imposed by this Declaration if the request for approval of the action also includes approval of the release.

(e) **Leases, Easements, Rights-of-Way, Licenses and Similar Interests and Vacations of Roadways.** Notwithstanding the provisions of Section 4.3(d), the Association may execute, acknowledge and deliver leases, easements, rights-of-way, licenses and other similar interests affecting the Common Areas and consent to vacation of roadways within and adjacent to the Common Areas, subject to such approvals as are required by ORS 94.665(4) and (5).

(f) **Limitations on Use.** Use of the Common Areas is subject to the following:

- (1) The provisions of this Declaration and any applicable supplemental declaration;
- (2) Any restrictions or limitations contained in any deed or other instrument conveying such property to the Association;

(3) Easements reserved or granted in this Declaration or any supplemental declaration;

(4) The Common Areas may not be used for the construction of residential structures at any time.

(5) The Board's right to:

(A) adopt Rules and Regulations regulating use and enjoyment of the Common Areas, including rules limiting the number of guests who may use the Common Areas;

(B) suspend the right of an Owner to use the Common Areas as provided in this Declaration;

(C) dedicate or transfer all or any part of the Common Areas, subject to such approval requirements as may be set forth in this Declaration;

(D) impose reasonable membership requirements and charge reasonable admission or other use fees for the use of any recreational facility situated upon the Common Areas;

(E) permit use of any recreational facilities situated on the Common Areas by Persons other than Owners, their families, lessees and guests with or without payment of use fees established by the Board;

(F) designate areas and facilities of Common Areas as Public Areas; and

(G) provide certain Owners the rights to the exclusive use of those portions of the Common Areas designated as Limited Common Areas.

4.4 **Delegation of Use.** Any Owner may extend the Owner's right of use and enjoyment of the Common Areas to the members of the Owner's family, lessees and social invitees, as applicable, subject to reasonable regulation by the Board of Directors. An Owner who leases the Owner's Home will be deemed to have assigned all such rights to the lessee of such Home for the period of the lease.

4.5 **Easements Reserved by Declarant.** So long as Declarant owns any Lot, Declarant reserves an easement for itself and its successor and assigns (including any builder who purchased more than one Lot from Declarant for purposes of development), over, under and across the Common Areas to carry out sales and rental activities necessary or convenient for the sale or rental of Lots, including, without limitation, advertising and "For Sale" signs. Declarant, for itself and its successors and assigns, hereby retains a right and easement of ingress and egress over, in, upon, under and across the Common Areas and the right to store materials thereon and to make such other use thereof as may be reasonably necessary or incident to the construction of the Improvements on the Property or other real property owned by Declarant; provided, however, that no such rights may be exercised by Declarant in such a way as to unreasonably interfere with the occupancy of, use of, enjoyment of or access to an Owner's Lot by the Owner or the Owner's family, tenants, employees, guests, or invitees.

4.6 **Easement to Serve Other Property.** Declarant reserves for itself and its duly authorized agents, successors, assigns and Mortgagees, and the developers of Improvements in all future phases of Stafford Meadows, a perpetual easement over the Common Areas for the purposes of enjoyment, use, access and development of the property, even if such property is never made subject to this Declaration, including but not limited to, reservations for the benefit of real property in the vicinity of the Property that is owned by or that may be owned in the future by West Hills Land Development LLC, its successors and assigns, for so long as the same reserves annexation rights to the Property. This easement includes, but is not limited to, a right of ingress and egress over the Common Areas for construction, utilities, water and sanitary sewer lines, communication lines, drainage facilities, irrigation systems and signs, and ingress and egress for the benefit of other portions of Stafford Meadows and any Additional Property that becomes subject to this Declaration or any property in the vicinity of the Property or Additional Property that is then owned by Declarant or an affiliate thereof. Declarant agrees that such users are responsible for any damage caused to the Common Areas resulting from their actions in connection with development of such property. If the easement is exercised for permanent use by such property and such property or any portion thereof benefiting from such easement is not made subject to this Declaration, Declarant, its successors or assigns will enter a reasonable agreement with the Association to share the cost of any maintenance of such facilities. The allocation of costs in any such agreement will be based on the relative extent of use of such facilities and the number of dwelling units in such property compared to the number of Homes in the Property.

4.7 **Limited Common Areas.** If any Limited Common Areas are included in an annexation declaration, the respective Limited Common Areas will be subject to a reciprocal access easement for the use by the Owners of the benefited Lots for vehicular access and utilities and communication lines serving such Lots. Such areas will be operated, maintained, replaced, and improved by the Association, but the entire cost thereof, including reserves for future maintenance, repairs, and replacements, will be assessed on an equal basis as Limited Common Area Assessments to the Owners of Lots to which such Limited Common Areas pertain.

Article 5

PROPERTY RIGHTS IN LOTS

5.1 **Use and Occupancy.** The Owner of a Lot in the Property is entitled to the exclusive use and benefit of such Lot, except as otherwise expressly provided in this Declaration, but the Lot is bound by, and each Owner and Declarant must comply with, the restrictions contained in Article 6, all other provisions of this Declaration and the provisions of any supplement or amendment to this Declaration.

5.2 **Easements Reserved.** In addition to any utility and drainage easements shown on any recorded plat, Declarant hereby reserves the following easements for the benefit of Declarant and the Association:

(a) **Adjacent Common Maintenance Area.** The Owner of any Lot that includes a Common Maintenance Area or adjoins or blends together visually with any Common Maintenance Area must, as the Association so requires, permit the Association to enter upon the Lot to perform the maintenance of such Common Maintenance Area. The Owner and Occupant of each Lot is

responsible for controlling such Owner's or Occupant's pets so they do not harm or otherwise disturb Persons performing such maintenance on behalf of the Association.

(b) **Utility Easements.** Easements for installation and maintenance of utilities and drainage facilities may be reserved over portions of certain Lots, as shown on any recorded plat. Within the utility easement areas, the Architectural Review Committee will not permit any structure, planting or other material to be placed or permitted to remain on the easement area if such structure, planting or other material may damage or interfere with the installation or maintenance of utilities, change the direction of flow of drainage systems or drainage infiltration facilities in the easements, or obstruct or retard the flow of water through drainage channels in the easements and/or to the extent not permitted in the City of Wilsonville Development Agreements. The easement area of each Lot and all Improvements in it will be maintained continuously by the Owner of the Lot, except for those Improvements for which a public authority or utility company is responsible, and except Common Maintenance Areas, which are maintained by the Association.

(c) **Construction on Adjoining Lot.** Declarant hereby reserves for the benefit of Declarant and its assigns a temporary easement over each Lot for access to the adjoining Lot for construction purposes, including temporary placement of ladders or scaffolding. Declarant will restore the Lot to its condition as it existed prior to such access and will be responsible for any damage to the Lot. Declarant hereby reserves for the benefit of Declarant and its assigns a temporary easement over each Lot Declarant then-currently owns to accommodate uses related to portions of the Property being used for the 2019 "Street of Dreams" event.

(d) **Utility Inspection and Repairs.** Each utility and communication service provider and its agents or employees have authority to access all Lots, but not Improvements constructed thereon, and the Common Areas on which communication, power, gas, drainage, sewage or water facilities may be located for installing, operating, maintaining, improving or constructing such facilities; reading meters; inspecting the condition of pipes, lines and facilities; and completing repairs. The Owner of any such Lot will be given advance notice if possible. In the case of an emergency, as determined solely by the utility or communication service provider, no prior notice will be required.

(e) **Easements for Encroachments.** Declarant grants reciprocal appurtenant easements of encroachment, and for maintenance and use of any permitted encroachment, between each Lot and any adjacent Common Areas and between adjacent Lots due to the unintentional placement or settling or shifting of the Improvements constructed, reconstructed or altered thereon (in accordance with the terms of this Declaration and the Design Guidelines) to a distance of not more than three feet, as measured from any point on the common boundary along a line perpendicular to such boundary. However, in no event will an easement for encroachment exist if such encroachment occurred due to willful and knowing conduct on the part of, or with the knowledge and consent of, the Person claiming the benefit of such easement.

(f) **Easements for Maintenance, Emergency and Enforcement.** Upon request given to the Owner and any Occupant, any Person authorized by the Association may enter a Lot to perform necessary maintenance, repair, or replacement of any property for which the Association has maintenance, repair or replacement responsibility under this Declaration, to make emergency repairs to a Lot that are necessary for the public safety or to prevent damage to Common Areas or to another Lot, or to enforce this Declaration or the Rules and Regulations. Requests for entry must be made in advance and for a reasonable time, except in the case of any emergency, when

the right of entry is immediate. An emergency entry does not constitute a trespass or otherwise create a right of action in the Owner of the Lot.

(g) **Future Easements.** Declarant reserves the nonexclusive right and power to grant and record such specific easements as may be necessary, in the sole discretion of Declarant, in connection with the development of any of the Property. The location of any such easement is subject to the written approval of the Owner of the burdened Lot, which approval will not unreasonably be withheld, delayed or conditioned.

Article 6

GENERAL USE RESTRICTIONS

6.1 **Structures Permitted.** No structures may be erected or permitted to remain on any Lot except a single Home and structures normally accessory thereto that have been constructed by Declarant or have first been approved by the Architectural Review Committee pursuant to Article 7. A Home will be deemed a permitted improvement on a Lot under this Section 6.1 notwithstanding that a Home may include within its exterior walls an independent living area with a separate outside entrance. This provision does not exclude construction of a private greenhouse or storage unit, or an accessory dwelling unit as defined by City of Wilsonville ordinances, provided that the location, size and design of such structures are in conformity with the applicable ordinances and permit requirements of City of Wilsonville, are compatible in design and style with the Home constructed on the Lot, and have been approved by the Committee.

6.2 **Residential Use.** Lots must only be used for residential purposes. Except with the consent of the Board of Directors, no trade, craft, business, profession, commercial or similar activity of any kind will be conducted on any Lot, nor may any goods, equipment, vehicles, materials, or supplies used in connection with any trade, service or business be kept or stored on any such Lot. The mere parking on a Lot of a vehicle bearing the name of a business will not, in itself, constitute a violation of this provision. Nothing in this Section 6.2 will be deemed to prohibit (a) activities relating to the sale of Homes; (b) the right of Declarant or any contractor or home builder to construct Improvements on any Lot, to store construction materials and equipment on such Lots in the normal course of construction, and to use one or more Homes as sales offices or model homes for purposes of sales in Stafford Meadows; and (c) the right of the Owner of a Lot to maintain his or her professional personal library, keep his or her personal business or professional records or accounts, handle his or her personal business or professional telephone calls or confer with business or professional associates, clients or customers in his or her Home by appointment only or to operate a registered or certified family child care home pursuant to ORS 329A.250 to 329A.500. The Board will not approve commercial activities otherwise prohibited by this Section 6.2 unless the Board determines that only normal residential activities would be observable outside of the Home and that the activities would not be in violation of applicable law. The Board may specify acceptable activities in the Rules and Regulations.

6.3 **Offensive or Unlawful Activities.** No noxious or offensive activities may be carried out upon the Property, nor will anything be done or placed on the Property that interferes with or jeopardizes the enjoyment of the Property, or that is a source of annoyance to Owners or Occupants. Occupants will use extreme care about creating disturbances, making noises or using musical instruments, radios, televisions, amplifiers and audio equipment that may disturb other Occupants.

No unlawful use may be made of the Property or any part thereof, and all valid laws, zoning ordinances and regulations of all governmental bodies having jurisdiction over the Property must be observed. Owners and other Occupants must not engage in any abusive or harassing behavior, either verbal or physical, or any form of intimidation or aggression directed at other Owners, Occupants, guests or invitees, or directed at the managing agent, its agents or employees, or vendors.

6.4 **Animals.** No animals, livestock, or poultry of any kind may be raised, bred, kept or permitted within any Lot other than seeing eye horses and a reasonable number of ordinary household pets that are not kept, bred, or raised for commercial purposes and that are reasonably controlled so as not to be a nuisance. The Board of Directors has the authority to determine what is an "ordinary household pet." Any unrestrained or barking dog constitutes a nuisance. Any inconvenience, damage or unpleasantness caused by such pets are the responsibility of their respective Owners. No animal is permitted to roam the Property unattended, and each dog must be kept on a leash while outside a Lot. The construction or installation of dog-runs and doghouses are subject to prior review and approval by the Architectural Review Committee pursuant to Article 7. An Owner or Occupant may be required to remove a pet upon receipt of the third written notice from the Board of violations of any rule, regulation or restriction governing pets within the Property.

6.5 **Maintenance of Structures.** Each Owner must maintain the Owner's Lot and Improvements thereon, including sidewalks adjacent to the Owner's Lot, and walkways and the driveway, in a clean and attractive condition, in good repair and in such fashion as not to create a fire or other hazard. Such maintenance includes, without limitation, exterior painting or staining, repair, replacement and care for roofs, gutters, downspouts, exterior building surfaces, walks, lights, perimeter fences and other exterior Improvements and glass surfaces. All repainting or re-staining, any change in type of roof or roof color and any exterior remodeling or changes are subject to prior review and approval by the Architectural Review Committee. Damage caused by fire, flood, storm, earthquake, riot, vandalism or other causes are likewise the responsibility of each Owner and must be restored within a reasonable time. Any change in appearance must first be approved by the Committee.

6.6 **Landscape Installation.** All landscaping on a Lot must be completed within a reasonable time not to exceed 90 days from the date of occupancy of the Home constructed on a Lot. In the event of undue hardship due to weather conditions, this provision may be extended for a reasonable length of time upon approval of the Architectural Review Committee. Landscape plans will be submitted to the Committee for approval. Landscaping in the Front Yards must not be changed by an Owner without the approval of the Committee. Notwithstanding such limitations, an Owner may utilize planting pots or other free standing, movable planters within the Front Yard of his or her Lot; provided that the planters and plants growing in the planters are properly maintained. The Board of Directors may regulate the number and type of such planters.

6.7 **Maintenance of Landscaping.** In any every portion of the Owner's Lot other than the Front Yard, the Owner will keep all shrubs, trees, grass and plantings of every kind on the Owner's Lot, neatly trimmed, properly cultivated, and free of trash, weeds and other unsightly material. Following initial installation by the Declarant or builder the Association will be responsible for maintenance and irrigation of landscaping of the Front Yard of Lots, including the irrigation equipment and controllers. No Owner or Occupant of one of these Lots may alter, change or tamper with the irrigation equipment, controllers or settings in a Front Yard the Association maintains, which settings belong to the Association.

6.8 **Boundary Fences.** The responsibility for and cost of maintenance, repair and replacement of fencing on boundary lines between Lots will be shared by the Owners on either side of the fence in accordance with ORS Chapter 96; provided, however, that the Association is responsible for the maintenance of any fencing or walls adjacent to Tracts E and H the cost of which will be a common expense.

6.9 **Fences, Hedges and Walls.** No fence, hedge, structure, wall, or retaining wall may be constructed or exist anywhere on any Lot without prior approval of the Architectural Review Committee and in accordance with its Design Guidelines. No planting or structure obstructing vision at driveways or intersections is permissible or may be maintained. Installation and maintenance of retaining walls that are required and approved by the Committee due to topographic conditions of a given Lot are the sole and absolute responsibility of the individual Lot Owner, are to be aesthetically incorporated into the landscaping of the Lot, and are not the responsibility of the Association.

6.10 **Pest and Weed Control.** No Owner will permit any thing or condition to exist upon any portion of the Property that will induce, breed or harbor infectious plant or animal diseases or noxious insects or vermin. Each Owner must control noxious weeds on the Owner's Lot.

6.11 **Parking.** Except as may otherwise be provided in the Rules and Regulations, parking in excess of 24 hours of boats, trailers, motorcycles, mobile homes, campers or other recreational vehicles or equipment, regardless of weight, are not be allowed on any part of the Property or on public streets within the Property unless within areas designated for such purposes by the Board of Directors or within the confines of an enclosed garage and approved by the Architectural Review Committee before construction or screened from view in a manner approved by the Committee. No portion of the vehicle may project beyond the screened area. If there is no rear fencing and the vehicle could be seen from outside the Lot other than from the front road, the vehicle must also be screened from view from that direction. Vehicles may not be used for storage of materials for more than 48 hours without approval from the Committee. No motor vehicle of any type may constructed, reconstructed, or repaired in such a manner as will be visible from neighboring property, nor may any vehicle be occupied for residential purposes while located within the Property. The Rules and Regulations may restrict the amount of noise vehicles may generate. The parking of vehicles is prohibited on any public or private street within the Property if posted or marked "No Parking" or if curbs are painted to restrict parking. Blocking a Common Area tract established under any plat of the Property, a roadway, Limited Common Area driveway, or alley is prohibited. No parking is permitted in Common Areas unless so posted.

6.12 **Vehicles in Disrepair.** No Owner will permit any vehicle that is in an extreme state of disrepair or not currently licensed to be abandoned or to remain parked on the Owner's Lot (unless screened from view) or on the Common Area or any street for a period in excess of 48 hours. A vehicle will be deemed in an "extreme state of disrepair" when the Board of Directors determines that its presence reasonably offends the Occupants of the area due to its appearance or continued inoperability. Should any Owner fail to remove such vehicle within five days following the date on which notice is mailed to him or her by the Association, the Association may have the vehicle removed from the Property and charge the expense of such removal to the Owner.

6.13 **Signs.** No signs may be erected or maintained on any Lot except that not more than one "For Sale" sign placed by the Owner, Declarant or a licensed real estate agent, not exceeding 24 inches high and 36 inches long, may be temporarily displayed within the Front Yard of any Lot or

inside of a first floor, front street facing window of a Home located on a Lot, and two such signs may be placed on a Lot during the course of initial construction of a dwelling on such Lot. "For Rent" and "For Lease" signs are prohibited. The restrictions contained in this paragraph do not prohibit the temporary placement of "political" signs on any Lot by the Owner, subject to reasonable regulations adopted by the Architectural Review Committee relating to size and length of display.

6.14 **Rubbish, Trash and Outside Storage.** No part of the Property may be used as a dumping ground for trash or rubbish of any kind, and no rubbish, refuse or garbage is allowed to accumulate. All garbage and other waste must be kept in appropriate sanitary containers for proper disposal and out of public view, except the night before and during garbage pickup days. Yard rakings, dirt, and other material resulting from landscaping work will not be dumped onto Lots, streets, or Common Maintenance Areas. Storage areas, and the storage of machinery and equipment are prohibited on any Lot, unless obscured from view of neighboring property and streets by an appropriate screen or enclosure approved by the Architectural Review Committee. Tarps and covers are prohibited except as otherwise provided in the Rules and Regulations and the Design Guidelines. Should any Owner or Occupant responsible for its generation fail to remove any such materials within 10 days following the date on which notice is mailed to the Owner or Occupant by the Board of Directors, the Association may have the materials removed and charge the expense of such removal to the Owner.

6.15 **Construction.** The construction of any building on any Lot, including painting and all exterior finish, must be completed within eight months from the beginning of construction so as to present a finished appearance when viewed from any angle, and the Home will not be occupied until so completed. In the event of undue hardship due to weather conditions or other causes beyond the reasonable control of the Owner, this time period may be extended for a reasonable length of time upon approval from the Architectural Review Committee. The building area must be kept reasonably clean and in workmanlike order, free of litter, during the construction period with a garbage can or other garbage disposal facility on the site during such period. Debris may not be deposited on any other Lot. All construction debris, stumps, trees, etc. must be periodically removed from each Lot by the builder or Owner, and such debris will not be dumped in any area within the Property unless approved by the Committee. The Rules and Regulations may impose reasonable limitations on the hours during which construction activities may take place. If construction has not commenced upon any Lot within one year after an Owner has acquired it, other than Declarant or an affiliate of Declarant, the Owner must install the sidewalk and landscape the area within 20 feet from the curb. The Owner will irrigate and maintain this area. The Committee may waive this requirement if it determines that construction will commence within a reasonable time. In any case, all unimproved or unoccupied Lots will be kept in a neat and orderly condition, free of brush, vines, weeds and other debris, and grass thereon must be cut or mowed at sufficient intervals to prevent creation of a nuisance or fire hazard.

6.16 **Temporary Structures.** No incomplete building or structure of a temporary character, nor any trailer, basement, tent, shack, garage, barn, or other outbuilding may be used on any Lot at any time as a residence either temporarily or permanently.

6.17 **Recreational Equipment.** Unless approved by the Architectural Review Committee or permitted by the Design Guidelines, no playground, athletic or recreational equipment or structures, including without limitation, permanently installed basketball backboards, hoops and related supporting structures, will be placed, installed or utilized on any Lot in view from any street,

sidewalk or Common Area within the Property. Portable basketball backboards, hoops, soccer goal nets, and related supporting structures may be used during daylight hours, so long as such equipment is stored out of view from any street, sidewalk, or Common Area within the Property.

6.18 **Service Facilities.** Service facilities (garbage containers, fuel tanks, clotheslines, etc.) will be screened so that the elements screened are not visible at any time from the street or a neighboring property. The Architectural Review Committee may develop guidelines for clotheslines that are consistent with the green sustainability objectives of Stafford Meadows. All telephone, power, natural gas, cable television and other communication lines will be placed underground, except as otherwise mandated by local jurisdictions or public utility companies.

6.19 **Antennas and Satellite Dishes.** Exterior antennas, satellite receivers, and transmission dishes are prohibited, except to the extent expressly mandated by rules adopted by the Federal Communication Commission. Specifically, ham radio antennas, cell towers, satellite dishes one meter or larger, television antennas or on masts 12 feet or higher and multi-point distribution antennas are prohibited. To the extent permitted by Federal Communication Commission rules, the Board of Directors may require all other antennas and dishes to be hidden from view from streets and adjoining dwellings. Other communication devices will not be permitted to be placed upon any Lot except in accordance with rules established by the Architectural Review Committee in accordance with Section 7.3.

6.20 **Exterior Lighting or Noisemaking Devices.** Except with the consent of the Architectural Review Committee, no exterior lighting or noisemaking devices may be installed or maintained on any Lot, other than as originally installed by the builder of the home and security alarms and fire alarms. Seasonal holiday lighting and decorations are permissible if consistent with any applicable Rules and Regulations and if installed not more than 30 days before and removed within 30 days after the celebrated holiday. The Committee may regulate the shielding or hours of use of lighting in order to reduce annoyance to neighboring properties. The location of air conditioning compressors must be approved by the Committee prior to installation.

6.21 **Subdividing or Partitioning Lots.** Except as otherwise provided in this Declaration, no Lot may be subdivided or partitioned, nor may its Lot lines be adjusted, without the approval of Clackamas County and the Architectural Review Committee.

6.22 **Grades, Slopes and Drainage.** Each Owner of a Lot accepts the burden of the established drainage pattern and grades, slopes and courses related thereto over any Lot or Common Area, and will not in any manner alter, modify or interfere with such drainage pattern, grades, slopes and courses, any public vegetated swale or rain garden, without the prior approval of the Architectural Review Committee, and then only to the extent and in the manner specifically approved. No structure, plantings or other materials may be placed or permitted to remain on or within any grades, slopes or courses, nor may any other activities be undertaken that may damage or interfere with established slope ratios, create erosion or sliding problems, or obstruct, change the direction of or retard the flow of water through drainage channels.

6.23 **Garages.** All garage doors must remain closed except to permit entrance and exit and in connection with outside activities. Garages will be used primarily for parking of vehicles, and only secondarily for storage, and must not be used as office or living space without the prior approval of the Architectural Review Committee.

6.24 **Windows, Decks, Porches and Outside Walls.** To preserve the attractive appearance of the Property, the Association may regulate the nature of items that may be placed in or on windows, decks, porches, and the outside walls so as to be visible from the street or Common Areas, including, without limitation, window air conditioners and fans. Window coverings, curtains, shutters, drapes or blinds, other than those of commercially produced quality, are not permitted to be visible from any public or private street, pathway, Common Area or adjacent property. No aluminum foil, reflective film, or similar treatment may be placed on windows or glass doors. Garments, rugs, laundry and other similar items may not be hung from windows, facades, porches or decks.

6.25 **Air Conditioning Units.** Window or portable air conditioning units are prohibited.

6.26 **Firearms and Fireworks.** Firearms may not be discharged within Stafford Meadows at any time. Firearms are to be unloaded at all times while in Stafford Meadows. Weapons including "BB" guns, pellet guns, dart guns, paint-ball guns and any other weapon capable of firing a projectile are considered firearms. Oregon statutory law prohibits the use of certain types of fireworks. Only fireworks considered legal are allowed. Owners and their guests must clean up any fireworks discharged in Stafford Meadows.

6.27 **Nonbiodegradable Substances.** No motor oil, paint or other caustic or nonbiodegradable substance may be deposited in any street drain, sewer system or on the grounds within Stafford Meadows. Any fine levied by a governmental agency and/or costs associated with the cleanup of any nonbiodegradable substance for any spill that is caused by any Owner or their guests will be the responsibility of the offending Owner.

6.28 **Leasing and Rental of Homes.** A Home may not be leased or rented for a period of less than 30 days. All leases of a Home must be by written agreement specifying that: (i) the tenant is subject to all provisions of the Declaration, Bylaws and Rules and Regulations; and (ii) failure to comply with any provision of the Declaration, Bylaws or Rules and Regulations constitutes a default under the rental agreement. The Owner must provide each tenant a copy of the Declaration, Bylaws and Rules and Regulations. The Owner is responsible for any violations by tenants and is directly responsible for either correcting or eliminating such violations or causing tenant to do the same.

6.29 **Rules and Regulations.** In addition, the Association from time to time may adopt, modify, or revoke such nondiscriminatory Rules and Regulations governing the conduct of Persons and the operation and use of the Property as it may deem necessary or appropriate to ensure the peaceful and orderly use and enjoyment of the Property. A copy of the Rules and Regulations, upon adoption, and a copy of each amendment, modification or revocation thereof, must be delivered by the Board of Directors promptly to each Owner. The Rules and Regulations may be adopted by the Board, except as may be otherwise provided in the Bylaws of the Association.

Article 7

ARCHITECTURAL REVIEW COMMITTEE

7.1 **Architectural Review.** No Improvement may be commenced, erected, placed or altered on any Lot, including without limitation re-landscaping, until the construction or landscaping plans, respectively, and specifications showing the nature, shape, heights, materials, colors and proposed location of the Improvement or landscaping, have been submitted to and approved in

writing by the Architectural Review Committee, except that construction by Declarant or any affiliate of Declarant will be presumed to have been approved and is thereby exempt from this review. Such exception for Declarant and such builders' construction will include without limitation the construction of buildings, hedges, walls, and fences. The building plans to be submitted will consist of one complete set of plans and specifications in the usual form showing insofar as appropriate, (i) size and dimensions of the Improvements; (ii) exterior design; (iii) approximate exterior color scheme; (iv) location of Improvements on the Lot, including setbacks, driveway and parking areas; and (v) location of existing trees to be removed. These plans and specifications must be left with the Committee until 60 days after notice of completion has been received by the Committee. This is for determining whether, after inspection by the Committee, the Improvement complies substantially with the plans and specifications that were submitted and approved. The Committee is not responsible for determining compliance with structural and building codes, zoning codes, or any other governmental regulations, all of which are the responsibility of the applicant. The procedure and specific requirements for review and approval of construction may be set forth in Design Guidelines adopted from time to time by the Committee. The Committee may charge a reasonable fee to cover the cost of processing an application. In all cases in which the Committee's consent is required by this Declaration, the provisions of this Article 7 apply, except that this Article 7 does not apply to construction by Declarant or any affiliate of Declarant.

7.2 **Committee Decision.** The Architectural Review Committee will render its decision with respect to a construction proposal within 30 working days after it has received all material required by it with respect to the application. In the event the Committee fails to render its approval or disapproval within 45 working days after the Committee has received all material required by it with respect to the proposal, or if no suit to enforce this Declaration has been commenced within one year after completion thereof, approval will not be required and the related provisions of this Declaration will be deemed to have been fully complied with.

7.3 **Committee Discretion.** The Architectural Review Committee may withhold consent to any proposed work if the Committee finds the proposed work would be inappropriate for the particular Lot or incompatible with the Design Guidelines or design standards that the Committee intends for Stafford Meadows. It is the intent and purpose of this Declaration to ensure quality of workmanship and materials, to ensure harmony of external design with the existing Improvements and with respect to topography and finished grade elevations, and to ensure compliance with the setback requirements contained in the conditions of approval of Clackamas County. Considerations such as siting, shape, size, color, design, materials, height, screening, impairment of the view from other Lots or other effect on the enjoyment of other Lots or the Common Area, disturbance of existing terrain and vegetation, and any other factors that the Committee reasonably believes to be relevant may be considered by the Committee in determining whether or not to consent to any proposed work. Regulations on siting of television antennas and satellite receiving dishes must be in conformance with any applicable Federal Communications Commission rules.

7.4 **Design Guidelines.**

(a) **Adoption of Design Guidelines.** Declarant or the Architectural Review Committee will prepare Design Guidelines, which may contain general provisions applicable to all of the Property as well as specific provisions that vary from Neighborhood to Neighborhood or any portions of a Neighborhood or Neighborhoods or as to types of use or Improvements. The Design Guidelines will interpret and implement the provisions of this Declaration for architectural review and

establish guidelines for architectural design, placement of buildings, color schemes, exterior finishes and materials and similar features that may be used in Stafford Meadows; provided, however that the Design Guidelines will not be in derogation of the minimum standards established by this Declaration. The Design Guidelines are not the exclusive basis for decisions of the Committee, and compliance with the Design Guidelines does not guarantee approval of any application. Regulations on siting of television antennas and satellite receiving dishes will be in conformance with any applicable Federal Communications Commission rules. The Design Guidelines may not unreasonably restrict solar energy systems in violation of ORS 105.880 or electrical vehicle charging stations in conflict with ORS 94.762.

(b) **Publication of Design Guidelines.** The Architectural Review Committee must make the Design Guidelines available to Owners and builders who seek to engage in development or construction within the Property. In Declarant's discretion, the Design Guidelines may be recorded, in which event the recorded version, as it may be amended from time to time, will control in the event of any dispute as to which version of the Design Guidelines was in effect at any particular time.

(c) **Amendment of Design Guidelines.** Declarant has sole and full authority to amend the Design Guidelines during the Development Period notwithstanding a delegation of reviewing authority to the Architectural Review Committee unless Declarant also delegates the power to amend to the Committee. Upon delegation of Declarant's right to amend, the Committee will have the authority to amend the Design Guidelines with the consent of the Board of Directors. Any amendments to the Design Guidelines will be prospective only and will not apply to require modifications to or removal of structures previously approved once the approved construction or modification has commenced. There is no limitation on the scope of amendments to the Design Guidelines, and such amendments may remove requirements previously imposed or otherwise make the Design Guidelines less restrictive.

7.5 **Membership: Appointment and Removal.** The Architectural Review Committee will consist of as many Persons as Declarant may from time to time appoint. Declarant, at its discretion, may appoint a single Person to serve as the Committee and may remove any member of the Committee from office at any time and may appoint new or additional members at any time. The Association will keep on file at its principal office a list of the names and addresses of the members of the Committee. Declarant may at any time delegate to the Board of Directors of the Association the right to appoint or remove members of the Committee. In such event, or in the event Declarant fails to appoint an Architectural Review Committee, the members of the Committee will be appointed by, and serve on behalf of, the Board, or if the Board fails to appoint such members, then the Board will serve as the Committee. The term of office for each member appointed by the Board will be one year unless lengthened by the Board at the time of appointment or unless the Board serves as the Committee, in which case the terms of the members will be the same as their terms as Board members. The Board may appoint any or all of its members to the Committee and is not required to appoint non-Board members. The Board may appoint one or more members to the Committee who are not Owners, but who have special expertise regarding the matters that come before the Committee. In the sole discretion of the Board, such non-Owner members of the Committee may be paid for such services, the cost of which may be paid by the applicants or treated as a common expense, as determined by the Board.

7.6 **Majority Action.** Except as otherwise provided in this Declaration, a majority of the members of the Architectural Review Committee has the power to act on behalf of the Committee, without the necessity of a meeting and without the necessity of consulting the remaining members of the Committee. The Committee may render its decision only by written instrument setting forth the action taken by the consenting members.

7.7 **Liability.** Neither the Architectural Review Committee nor any member thereof is liable to any Owner, Occupant, builder or developer for any damage, loss or prejudice suffered or claimed on account of any action or failure to act of the Committee or a member of the Committee, and the Association will indemnify the Committee and its members therefrom, provided only that the member has, in accordance with the actual knowledge possessed by him or her, acted in good faith.

7.8 **Nonwaiver.** Consent by the Architectural Review Committee to any matter proposed to it or within its jurisdiction will not be deemed to constitute a precedent or waiver impairing its right to withhold approval as to any similar matter thereafter proposed or submitted to it for consent.

7.9 **Appeal.** At any time after Declarant has delegated appointment of the members of the Architectural Review Committee to the Board of Directors pursuant to Section 7.5, any Owner adversely affected by action of the Committee may appeal such action to the Board. Appeals must be made in writing within 10 days of the Committee's action and must contain specific objections or mitigating circumstances justifying the appeal. If the Board is already acting as the Committee, the appeal will be treated as a request for a rehearing, in which case the Board will meet and receive evidence and argument on the matter. A final, conclusive decision will be made by the Board within 15 working days after receipt of such notification.

7.10 **Effective Period of Consent.** The Architectural Review Committee's consent to any proposed work will automatically be revoked one year after issuance unless construction of the work has been substantially commenced in the judgment of the Committee and thereafter diligently pursued, or unless the Owner has applied for and received an extension of time from the Committee.

7.11 **Estoppel Certificate.** Within 20 business days after written request is delivered to the Architectural Review Committee by any Owner, and upon payment to the Committee of a reasonable fee fixed by the Committee to cover costs, the Committee will provide such Owner with an estoppel certificate executed by a member of the Committee and acknowledged, certifying with respect to any Lot owned by the Owner, that as of the date of the certificate either (a) all Improvements made or done upon or within such Lot by the Owner comply with this Declaration or (b) such Improvements do not so comply, in which event the certificate must also identify the noncomplying Improvements and set forth with particularity the nature of such noncompliance. Any purchaser from the Owner, and any Mortgagee or other encumbrancer, is entitled to rely on such certificate with respect to the matters set forth therein, such matters being conclusive as between Declarant, the Committee, the Association and all Owners, and such purchaser or Mortgagee.

7.12 **Enforcement.** If during or after the construction the Architectural Review Committee finds that the work was not performed in substantial conformance with the approval granted, or that the required approval was not obtained, the Committee will notify the Owner in writing of the noncompliance, specifying the particulars of the noncompliance. The Committee may require conforming changes to be made or that construction be stopped. The cost of any required changes will be borne by the Owner. The Committee has the power and authority to order any manner

of changes or complete removal of any Improvement, alteration, or other activity for which prior written approval from the Committee is required and has not been obtained or waived in writing. If an Owner fails to comply with an order of the Committee, then, subject to the Owner's right of appeal under Section 7.9, either the Committee or the Board of Directors may enforce compliance in accordance with the procedures set forth in Section 11.1.

Article 8

ASSOCIATION

Declarant has organized, or before conveyance of the first Lot will organize, an association of all of the Owners within Stafford Meadows. Such Association, and its successors and assigns, will be organized as an Oregon nonprofit corporation under the name "**Stafford Meadows Homeowners Association**," and will have such property, powers and obligations as are set forth in this Declaration for the benefit of the Property and all Owners of Lots located therein.

8.1 **Organization.** Declarant will, before the first Lot is conveyed to an Owner, organize the Association as a nonprofit corporation under the general nonprofit corporation laws of the State of Oregon. The Articles of Incorporation of the Association will provide for its perpetual existence, but in the event the Association is at any time dissolved, whether inadvertently or deliberately, it will automatically be succeeded by an unincorporated association of the same name. In that event, the unincorporated association will have all the property, powers and obligations of the incorporated association existing immediately prior to dissolution. To the greatest extent possible, any successor unincorporated association will be governed by the Articles of Incorporation and Bylaws of the Association as if they had been made to constitute the governing documents of the unincorporated association and will be served by the members of the Board of Directors and the officers who served immediately prior to dissolution.

8.2 **Membership.** Every Owner of one or more Lots within the Property must, immediately upon creation of the Association and thereafter during the entire period of such Owner's ownership of one or more Lots within the Property, be a member of the Association. Such membership commences, exists, and continues simply by virtue of such ownership; expires automatically upon termination of such ownership; and need not be confirmed or evidenced by any certificate or acceptance of membership.

8.3 **Voting Rights.** The Association has two classes of voting membership:

Class A. Class A Members are all Owners with the exception of the Class B Member and are entitled to one vote for each Lot owned. When more than one Person holds an interest in any Lot, all such Persons are members. The vote for such Lot is exercised as they among themselves determine, but in no event will more than one vote be cast with respect to any Lot.

Class B. The Class B Member is Declarant, who is entitled to three votes for each Lot owned by Declarant. The Class B Membership will cease and be converted to Class A Membership on the happening of any of the following events, whichever occurs earlier:

(1) When all of the Lots in the final phase of development of Stafford Meadows have been Sold and conveyed to Owners other than a successor Declarant; or

(2) At such earlier time as Declarant may elect in writing to terminate Class B Membership.

8.4 **General Powers and Obligations.** The Association has, exercises and performs all of the following powers, duties, and obligations:

(a) The powers, duties and obligations granted to the Association by this Declaration.

(b) The powers and obligations of a nonprofit corporation pursuant to the general nonprofit corporation laws of the State of Oregon.

(c) The powers, duties and obligations of a homeowners association pursuant to the Oregon Planned Community Act.

(d) Any additional or different powers, duties and obligations necessary or desirable for carrying out the functions of the Association pursuant to this Declaration or otherwise promoting the general benefit of the Owners within the Property.

The powers and obligations of the Association may from time to time be amended, repealed, enlarged or restricted by changes in this Declaration made in accordance with the provisions of this Declaration, accompanied by any required changes in the Articles of Incorporation or Bylaws of the Association made in accordance with such instruments and with the nonprofit corporation laws of the State of Oregon.

8.5 **Specific Powers and Duties.** The powers and duties of the Association include, without limitation, all of the following:

(a) **Maintenance and Services.** The Association will provide maintenance and services for the Property as provided in Article 9 and other provisions of this Declaration.

(b) **Insurance.** The Association will obtain and maintain in force policies of insurance as determined by the Board of Directors and in accordance with any requirements in this Declaration or the Bylaws of the Association.

(c) **Rulemaking.** The Association will make, establish, promulgate, amend and repeal Rules and Regulations as provided in Section 0.

(d) **Assessments.** The Association will adopt budgets and impose and collect Assessments as provided in Article 10.

(e) **Enforcement.** The Association will perform such acts, whether or not expressly authorized by this Declaration, as may be reasonably necessary to enforce the provisions of this Declaration and the Rules and Regulations adopted by the Association, including, without limitation, enforcement of the decisions of the Architectural Review Committee. Nothing in this Declaration may be construed as requiring the Association to take any specific action to enforce violations.

(f) **Employment of Agents, Advisers and Contractors.** The Association, through its Board of Directors, may employ the services of any Person as manager; hire employees to manage, conduct and perform the business, obligations and duties of the Association; employ professional counsel and obtain advice from such Persons such as, but not limited to, landscape architects, architects, planners, attorneys and accountants; and contract for or otherwise provide for all services necessary or convenient for the management, maintenance and operation of the Property; provided, however, the Board may not incur or commit the Association to incur legal fees in excess of \$5,000 for any specific litigation or claim matter or enter into any contingent fee contract or any claim in excess of \$100,000 unless the Owners have enacted a resolution authorizing the incurring of such fees by a vote of 75 percent of the total voting rights of the Association. These limitations are not applicable to legal fees incurred in defending the Association or the Board from claims or litigation brought against them. The limitations set forth in this paragraph (f) will increase by 10 percent on each fifth anniversary of the recording of this Declaration.

(g) **Borrow Money.** The Association may borrow and repay money for the purpose of performing its duties under this Declaration; provided, however, that such borrowing in any calendar year may not exceed 20 percent of the estimated budgeted expenses of the Association for that calendar year unless the owners have enacted a resolution authorizing the project by a majority of the voting rights of the members. The Association may pledge Association income to secure such borrowing, and, subject to Section 4.3(d), encumber the Common Areas as security for the repayment of such borrowed money.

(h) **Acquire and Hold Title to Property.** The Association may acquire and hold title to real and personal property and interests therein, and must accept any real or personal property, leasehold or other property interests within Stafford Meadows conveyed to the Association by Declarant.

(i) **Transfers, Dedications, Encumbrances and Easements.** Except as otherwise provided in Sections 4.3(d) and 4.3(e), the Association may sell, transfer or encumber and grant easements upon all or any portion of the Common Area, or other real property to which it then holds title, to a Person, whether public or private, and dedicate or transfer all or any portion of such Common Area or property to any public agency, authority or utility for public purposes.

(j) **Create Classes of Service and Make Appropriate Charges.** The Association may, in its sole discretion, create various classes of service and make appropriate Individual Assessments or charges therefor to the users of such services, including, but not limited to, reasonable admission and other fees for the use of any and all recreational facilities situated on the Common Areas, without being required to render such services to those of its members who do not assent to such charges and to such related Rules and Regulations as the Board deems proper. In addition, the Board has the right to discontinue any service upon nonpayment of Assessments or to eliminate any service for which there is no demand or for which there are inadequate funds to maintain the same.

(k) **Restoring Damaged Improvements.** In the event of damage to or destruction of Common Areas or other property that the Association insures, the Board of Directors or its duly authorized agent must file and adjust all insurance claims and obtain reliable and detailed estimates of the cost of repairing or restoring the property to substantially the condition in which it existed prior to the damage, allowing for changes or Improvements necessitated by changes in

applicable building codes. If a decision is made not to restore the damaged Improvements, and no alternative Improvements are authorized, the affected property will be cleared of all debris and ruins and thereafter will be maintained by the Association in a neat and attractive, landscaped condition. If insurance proceeds are insufficient to cover the costs of reconstruction, the Board may levy Special Assessments to cover the shortfall against those Owners responsible for the premiums for the applicable insurance coverage. Any insurance proceeds remaining after paying the costs of repair or reconstruction, or after such settlement as is necessary and appropriate, will be retained by the Association for the benefit of all or some of the Owners, as appropriate, and placed in a capital Improvements account. This is a covenant for the benefit of Mortgagees and may be enforced by the Mortgagee of any affected Lot.

(l) **Security.** The Association may, but is not obligated to, maintain or support certain activities within Stafford Meadows designed to make the Property more enjoyable or safer than it otherwise might be. **Neither the Association, Declarant nor any managing agent will be considered insurers or guarantors of security or safety within the Property, nor will either be held liable for any loss or damage by reason of failure to provide adequate security or ineffectiveness of security or safety measures undertaken. No representation or warranty is made that any system or measure, including any mechanism or system for limiting access to the Property, cannot be compromised or circumvented, nor that any such system or measure undertaken will in all cases prevent loss or provide the detection or protection for which it is designed or intended. Each Owner acknowledges and agrees that the Association, the Board of Directors and any managing agent are not insurers and that each Person using the Property assumes all risks for personal injury and loss or damage to property resulting from acts of third parties.**

(m) **Services.** The Association may provide or contract for such services as the Board of Directors may reasonably deem to be of benefit to the Property, including, without limitation, landscape services, garbage and trash removal and security services.

(n) **Implied Rights and Obligations.** The Association may exercise any other right or privilege reasonably to be inferred from the existence of any right or privilege expressly given to the Association under this Declaration or reasonably necessary to effectuate any such right or privilege.

8.6 **Liability.** Neither a member of the Board of Directors nor an officer of the Association or member of the Architectural Review Committee or any other committee established by the Board will be liable to the Association, any Owner or any third party for any damage, loss or prejudice suffered or claimed on account of any action or failure to act in the performance of his or her duties, so long as the individual acted in good faith; believed that the conduct was in the best interests of the Association, or at least was not opposed to its best interests; and, in the case of criminal proceedings, had no reason to believe the conduct was unlawful. In the event any member of the Board or any officer or committee member of the Association is threatened with or made a party to any proceeding because the individual was or is a director, officer, or committee member of the Association, the Association will defend the individual against such claims and indemnify the individual against liability and expenses incurred to the maximum extent permitted by law.

8.7 **Interim Board; Turnover Meeting.** Declarant has the right to appoint an interim board of one to three directors, who will serve as the Board of Directors of the Association until

replaced by Declarant or until their successors take office at the Turnover Meeting following termination of Class B Membership. Declarant will call a meeting of the Association for the purpose of turning over administrative responsibility for the Property to the Association not later than 90 days after termination of the Class B Membership in accordance with Section 8.3. At the Turnover Meeting the interim directors will resign and their successors will be elected by the Owners, as provided in this Declaration and in the Bylaws of the Association. If Declarant fails to call the Turnover Meeting required by this Section 8.7, any Owner or Mortgagee of a Lot may call the meeting by giving notice as provided in the Bylaws.

8.8 Contracts Entered into by Declarant or Before Turnover Meeting. Notwithstanding any other provision of this Declaration, any management contracts, service contracts or employment contracts entered into by Declarant or the Board of Directors on behalf of the Association before the Turnover Meeting will have a term of not more than three years. In addition, any such contract must provide that it may be terminated without cause or penalty by the Association or Board upon not less than 30 days' notice to the other party given not later than 60 days after the Turnover Meeting. The limitations contained in this Section 8.8 do not apply to those contracts referred to in ORS 94.700(2).

8.9 Bylaws. The Bylaws of the Association and any amendment or modification of the Bylaws will be recorded in the Deed Records of Clackamas County, Oregon. On behalf of the Association, the Declarant will adopt and record the initial Bylaws as provided in ORS 94.625.

Article 9

MAINTENANCE

9.1 Common Maintenance Areas. The Common Maintenance Areas include the Common Areas, Limited Common Areas, Common Easement Areas, and the Front Yards of Lots in Stafford Meadows, and the wall maintenance areas designated on the Plat, until such maintenance is assumed by the local jurisdiction, if ever.

9.2 Maintenance and Lighting of Common Maintenance Areas. The Association is responsible for exterior lighting, if any, in the Common Areas and will perform all maintenance upon the Common Maintenance Areas, including, but not limited to, entrance monuments, gates, fences, walls in Common Areas or bordering the Common Areas (including without limitation any fence or wall along S.W. Boeckman Road, and any public vegetated swale along any roadway in the Property), signs, parking areas, pathways, bicycle paths, unless the maintenance thereof is assumed by a public body. Sidewalks, notwithstanding the public easement over them, are the Lot Owner's responsibility to maintain, repair, and replace and to keep free of leaves, ice, and snow. The Association is responsible for maintenance and irrigation of landscaping in the Front Yards and the walls constructed in the wall maintenance easement areas designated on the Plat, and for the design and any modification thereof.

(a) In the Front Yards, irrigation systems, including related controllers, monitors, and equipment, belong to the Lot Owner. Landscaping irrigation settings will be set by the Association and no Owner may tamper with or change such settings. The Association has the right of access to each such controller, monitor, or other equipment wherever located on a Lot. The cost of water for irrigation of the Front Yards is the responsibility of the Association and will be a common

expense. Rain gardens are part of the Property's overall stormwater treatment plan, whether located in the public right of way or on a portion of a Lot; any rain garden located on any Lot will be the responsibility of the Association to maintain as part of the Lot's Front Yard landscaping, which must be performed so that the rain garden area works for its intended stormwater collection and filtering functions. The Association will also maintain and irrigate the area of the street right-of-way between the curb and the sidewalk. Such areas will be maintained in attractive condition and in a good and workmanlike manner to render them fit for the purposes for which they are intended. The maintenance of Front Yards by the Association does not include maintenance of special features, which are the Owner's responsibility, including but not limited to decorative water features (ponds, streams, waterfalls, etc.), bridges, gazebos, foot paths, putting greens, or any other Improvement other than ordinary landscaping, which are the responsibility of the Lot Owner. Front Yard maintenance expenses borne by the Association will be Individual Expenses to be determined by the board of directors according to Section 10.3 below.

(b) The Association is hereby assigned and assumes the City of Wilsonville Development Agreements in respect of all the Property thereunder that subjected to this Declaration. Except to the extent of the Declarant's obligations to install, construct, and for the stated bond period therein, inspect and maintain, certain improvements on the affected Common Areas, this assignment and assumption includes Declarant's on-going maintenance, repair, inspection, and replacement obligations under the City of Wilsonville Development Agreements.

9.3 **Maintenance of Shared Irrigation Systems and Utility Facilities.** The Association will perform or contract to perform maintenance of (i) all irrigation systems and facilities within Common Maintenance Areas, and (ii) any private utilities serving a Common Area (other than Common Easement Areas), except to the extent such maintenance is performed by the utilities furnishing such services. The Association is not liable for any interruption or failure of such services. Each Owner is responsible for maintaining utility lines within his or her Lot other than those serving the Common Maintenance Areas.

9.4 **Owner's Responsibility.** Except as otherwise provided in this Declaration or by written agreement with the Association, all maintenance of the Lots and Improvements, including landscaping for which the Association is not responsible, walkways, and the driveway thereon as provided in Section 6.5 and 6.7 will be the sole responsibility of the Lot Owner, who will maintain the Lot in a neat and attractive condition in accordance with the community-wide standard of Stafford Meadows. Sidewalks, notwithstanding the public easement over them, are the Lot Owner's responsibility to maintain, repair, and replace and to keep free of leaves, ice, and snow. The Association may, in the discretion of the Board of Directors, assume the maintenance responsibilities of such Owner if, in the opinion of the Board, the level and quality of maintenance being provided by such Owner does not satisfy such standard. Before assuming such maintenance responsibilities, the Board will notify the Owner in writing of its intention to do so, and if such Owner has not commenced and diligently pursued remedial action within 15 days after mailing of such written notice, then the Association may proceed. The expenses of such maintenance by the Association will be reimbursed to the Association by the Owner, together with interest as provided in Section 11.3. Such charges will be an Individual Assessment and lien on the Lot as provided in Sections 10.4(d) and 11.1.

9.5 **Damage Liability.** Any damage to any Common Maintenance Area by Owners or their children, agents, visitors, friends, relatives, tenants, Occupants or service personnel, to the extent

not covered by the Association's insurance (including any deductible), will be assessed to such Owners as an Individual Assessment.

9.6 **Maintenance Plan.** Declarant will initially prepare and thereafter the Board of Directors must implement, review, and update a maintenance plan (the "**Maintenance Plan**") for the maintenance, repair and replacement of all property for which the Association has maintenance, repair or replacement responsibility under this Declaration or the Bylaws or the Oregon Planned Community Act. The Maintenance Plan will describe the maintenance, repair or replacement to be conducted; include a schedule for maintenance, repair or replacement; be appropriate for the size and complexity of the maintenance, repair and replacement responsibility of the Association; and address issues that include, but are not limited to, warranties and the useful life of the items of which the Association has maintenance, repair or replacement responsibility. The Board must review and update the Maintenance Plan as necessary. Changes or updates to the Maintenance Plan will be based on advice of competent experts or consultants. For a period of 10 years following recording of the Declaration, any changes to the Maintenance Plan without the approval of the Declarant and the original general contractor may void any applicable warranty and will release them from liability for any damage resulting from such change.

Article 10

ASSESSMENTS

10.1 **Purpose of Assessments.** The Association may levy Assessments. The Assessments levied by the Association must be used exclusively to promote the recreation, health, safety and welfare of the Owners and Occupants of the Property and for the improvement, operation and maintenance of the Common Maintenance Areas.

10.2 **When Lots Become Subject to Assessment.** Upon the first sale of each Lot to a purchaser other than (i) Declarant, (ii) another developer or builder in a bulk sale of Lots, (iii) a successor declarant, or (iv) an affiliate of Declarant, the Lot Sold becomes subject to assessment and the Owner will pay General Assessments, Special Assessments, Emergency Assessments, Limited Common Area Assessments, and if any, Individual Assessments.

10.3 **Allocation of Assessments.** Except as may otherwise be provided in an applicable supplemental declaration annexing Additional Property to this Declaration, all Lots subject to assessment will pay an equal share of the General Assessments, Special Assessments, and Emergency Assessments. The cost of Front Yard maintenance, including landscaping upkeep, repair and operation of irrigation systems, and water for irrigation, will be Individual Expenses, which will be reasonably determined by the board of directors based on the size and features of any given Lot's Front Yard and categories of corresponding assessments for the Front Yard maintenance performed by the Association. The board has the authority to create categories of Lots based on their size and Front Yard features, including without limitation that some Lots will have private rain gardens in their Front Yards and others will not, for the purpose of creating categories of Lots in respect of the Front Yard assessments; in other words, notwithstanding that Front Yard maintenance costs will be assessed as Individual Assessments, Front Yards may be lumped together by size and feature for simplification of assessment invoicing. If the irrigation water is not separately metered on a Lot, the board of directors will reasonably estimate irrigation as between Lots sharing a landscaping water meter and allocate the water costs accordingly or according to categories of Lots for Front Yard assessment.

10.4 **Type of Assessments.** The Association is authorized to levy the following types of Assessments:

(a) **General Assessments.** The Association will levy General Assessments for the common expenses incurred by or on behalf of the Association in accordance with this Declaration. The Board of Directors will from time to time and at least annually prepare an operating budget for the Association, taking into account the current costs of maintenance and services and future needs of the Association, any previous over-assessment and any common profits of the Association. The budget must take into account the number of Lots subject to assessment as of the first day of the fiscal year for which the budget is prepared and the number of Lots reasonably anticipated to become subject to assessment during the fiscal year. The budget may be based upon a greater number of Lots than those reasonably anticipated to be subject to assessment during the fiscal year if the Declarant agrees to subsidize the Association for any shortfall in the Operations Fund. The budget will provide for such reserve or contingency funds as the Board deems necessary or as may be required by law, but not less than the reserves required by Section 10.7. General Assessments for such operating expenses and reserves will then be apportioned among the Lots as provided in Section 10.3. The Board may revise the budget and adjust the General Assessment from time to time during the year. Within 30 days after the adoption of a final budget by the Board, the Board will send a copy of the final budget to each Owner. If the Board fails to adopt a budget, the last adopted budget continues in effect. The manner of billing and collection of Assessments is as provided in the Bylaws.

(b) **Special Assessments.** The Board of Directors may levy during any fiscal year a Special Assessment, applicable to that year only, for the purpose of deferring all or any part of the cost of any construction or reconstruction, unexpected repair, or acquisition or replacement of a described capital Improvement, or for any other one-time expenditure not to be paid for out of General Assessments. Special Assessments for acquisition or construction of new capital Improvements or additions that in the aggregate in any fiscal year exceed an amount equal to 15 percent of the budgeted gross expenses of the Association for the fiscal year may be levied only if approved by a majority of the voting rights voting on such matter, together with the written consent of the Class B Member, if any. Prior to the Turnover Meeting, any Special Assessment for acquisition or construction of new capital Improvements or additions must be approved by not less than 50 percent of the Class A voting rights, together with the written consent of the Class B Member. Special Assessments will be apportioned as provided in Section 10.3 and may be payable in lump sum or in installments, with or without interest or discount, as determined by the Board.

(c) **Emergency Assessments.** If the General Assessments levied at any time are or will become inadequate to meet all expenses incurred under this Declaration for any reason, including nonpayment of any Owner's Assessments on a current basis, the Board of Directors will immediately determine the approximate amount of such inadequacy and issue a supplemental budget, noting the reason therefor, and levy an Emergency Assessment for the amount required to meet all such expenses on a current basis. Emergency Assessments will be apportioned as set forth in Section 10.3 and payable as determined by the Board.

(d) **Limited Common Area Assessments.** General Assessments, Special Assessments and Emergency Assessments relating to maintenance, upkeep, repair, replacement or improvements to Limited Common Areas will be assessed exclusively and on an equal basis to the Lots having the right to use such Limited Common Areas.

(e) **Individual Assessments.** Any common expense or any part of a common expense benefiting fewer than all of the Lots may be assessed as Individual Assessments exclusively against the Lots benefited. Individual Assessments include, without limitation, charges for services provided under Sections 8.5(j), 9.2(a), and 10.4(a) and any loss or cost incurred by the Association that the Board of Directors determines is the fault of one or more Owners and not paid by insurance. Individual Assessments also include default Assessments levied against any Lot to reimburse the Association for costs incurred in bringing such Lot or its Owner into compliance with the provisions of this Declaration or the Rules and Regulations of the Association and for fines or other charges imposed pursuant to this Declaration for violation thereof. Unless otherwise provided by the Board, Individual Assessments will be due 30 days after the Board has given written notice thereof to the Owners subject to the Individual Assessments.

(f) **Working Fund Assessments.** Upon the first sale of a Lot to a purchaser other than a successor Declarant and upon any subsequent sale of such Lot, the purchaser will pay to the Association a Working Fund Assessment equal to two times the monthly General Assessment then applicable to the Lot. The Board of Directors may deposit Working Fund Assessments either in the Operations Fund or in the Reserve Fund, at the discretion of the Board.

10.5 **Assessment of Additional Property.** When Additional Properties are annexed to Stafford Meadows, the Lots included therein become subject to Assessments from the date of such annexation to the extent provided in Section 10.2. The Board of Directors, however, at its option may elect to recompute the budget based upon the additional Lots subject to Assessment and additional Common Areas and recompute General Assessments for all Lots, including the new Lots, for the balance of the fiscal year. Notwithstanding any provision of this Declaration apparently to the contrary, a declaration annexing Additional Property may provide that such Additional Property does not have the right to use a particular Common Area or facility located thereon, in which case such Additional Property will not be assessed for the costs of operating, maintaining, repairing, replacing or improving such Common Area or facility.

10.6 **Operations Fund.** The Association will keep all funds received by it as Assessments, other than reserves described in Section 10.7 or Working Fund Assessments deposited in the Reserve Fund, separate and apart from its other funds, in an Operations Fund in a bank account in the name of the Association. The Association will use such fund for the purpose of promoting the recreation, health, safety and welfare of the residents within the Property and in particular for the improvement and maintenance of properties, services and facilities devoted to this purpose and related to the use and enjoyment of the Common Maintenance Areas and the Lots, including but not limited to:

- (a) Payment of the cost of operation, maintenance, utilities, services, repairs, and replacements for the Common Maintenance Areas.
- (b) Payment of the cost of insurance maintained by the Association.
- (c) Payment of taxes assessed against the Common Areas and any Improvements thereon.
- (d) Payment of the cost of other services that the Association deems to be of general benefit to the Owners, including, but not limited to, accounting, legal, and secretarial services.

10.7 **Reserve Fund.**

(a) **Establishment of Account.** Declarant, on behalf of the Association, will conduct an initial reserve study as described in Section 10.7(c) and establish a Reserve Fund in a bank account in the name of the Association to fund major maintenance, repair or replacement of any common properties that will normally require replacement in whole or in part in more than one and less than 30 years; for exterior painting if the Common Maintenance Areas or other property to be maintained by the Association includes exterior painted surfaces; and for other items, whether or not involving Common Maintenance Areas, if the Association has responsibility to maintain the items, including items required by the Maintenance Plan established pursuant to Section 9.6. The Reserve Fund need not include those items that can reasonably be funded from the general budget or other funds of the Association or for those items for which one or more, but less than all, Owners are responsible for maintenance and replacement under the provisions of this Declaration or the Bylaws. Nothing in this Section 10 prohibits prudent investment of the Reserve Fund.

(b) **Funding of Reserve Fund.** The Reserve Fund will be funded by Assessments against the individual Lots assessed for maintenance of the items for which the Reserve Fund is being established, which sums will be included in the regular General Assessment for the Lot and the Limited Common Area Assessments, if applicable. The Board, however, may borrow funds from the Reserve Fund to meet high seasonal demands on the regular operating funds or to meet other temporary expenses that will later be paid from General Assessments, Special Assessments, or Emergency Assessments. The Reserve Fund also includes Working Fund Assessments to the extent so allocated by the Board of Directors pursuant to Section 10.4(f). The Reserve Fund will be established in the name of the Association. The Association is responsible for administering the Reserve Fund and making periodic payments into the account. The Board of Directors or the Owners may not vote to eliminate funding the Reserve Account unless the Board determines that the Reserve Account will be adequately funded for the following year, except that after the Turnover Meeting the Board, with the approval of all Owners, may, on an annual basis, elect not to fund the Reserve Fund for the following year. Assessments paid into the Reserve Fund are the property of the Association and are not refundable to sellers or Owners of Lots. Sellers of the Lots, however, may treat their outstanding share of the Reserve Fund as a separate item in any sales agreement.

(c) **Reserve Studies.** The reserve portion of the initial Assessment determined by Declarant will be based on a reserve study described in this paragraph (c) or other sources of information. The Board of Directors will annually conduct a reserve study, or review and update an existing study, to determine the Reserve Fund requirements, and may adjust the amount of payments as indicated by the study or update and provide other reserve items that the Board, in its discretion, may deem appropriate. The reserve study will:

- (1) Identify all items for which reserves are to be established;
- (2) Include the estimated remaining useful life of each item as of the date of the reserve study; and
- (3) Include for each item, as applicable, an estimated cost of maintenance, repair and replacement at the end of its useful life.

(d) **Use of Reserve Fund.** If a Reserve Fund is required, the Reserve Fund will be used only for the purposes for which the reserves have been established and kept separate from other funds. After the Turnover Meeting, however, the Board of Directors may borrow funds from the Reserve Fund to meet high seasonal demands on the regular operating funds or to meet unexpected increases in expenses if the Board has adopted a resolution, which may be an annual continuing resolution, authorizing the borrowing of funds. Not later than the adoption of the budget for the following year, the Board will adopt by resolution a written payment plan providing for repayment of the borrowed funds within a reasonable period. Assessments paid into the Reserve Fund are the property of the Association and are not refundable to sellers or Owners of Lots. Sellers of the Lots, however, may treat their outstanding share of the Reserve Fund as a separate item in any sales agreement.

10.8 **Declarant's Subsidy.** Declarant may, but is not be obligated to, reduce the General Assessments for any fiscal year by payment of a subsidy (in addition to any other amounts then owed by Declarant), which may be either a contribution, an advance against future Assessments due from Declarant or a loan, in Declarant's discretion. Any such subsidy will be disclosed as a line item in the income portion of the Association's budget. Payment of such subsidy in any year will not obligate Declarant to continue payment of such subsidy in future years unless otherwise provided in a written agreement between the Association and Declarant.

10.9 **Commencement of Assessment Obligation; Time of Payment.** The obligation to pay Assessments under this Declaration commences as to each Lot on the first day of the month after such Lot becomes subject to Assessment. The first annual General Assessment levied on each Lot will be adjusted according to the number of months remaining in the fiscal year at the time Assessments commence for such Lot.

10.10 **Payment of Assessments.** Assessments must be paid in such manner and on such dates as the Board of Directors may establish. Unless the Board otherwise provides, the General Assessment is due and payable in advance on the first day of each fiscal year. If any Owner is delinquent in paying any Assessments or other charges levied on his or her Lot, the Board may require the outstanding balance on all Assessments to be paid in full immediately. Until the Turnover Meeting, any obligation of Declarant to pay Assessments may be satisfied in the form of cash or by "in kind" contributions of services or materials, or by a combination of these.

10.11 **Creation of Lien and Personal Obligation of Assessments.** Declarant, for each Lot owned by it within the Property, hereby covenants, and each Owner of any Lot by acceptance of a conveyance thereof, whether or not so expressed in any such conveyance, will be deemed to covenant to pay to the Association all Assessments or other charges as may be fixed, established and collected from time to time in the manner provided in this Declaration or the Association Bylaws. Such Assessments and charges, together with any interest, late charges, expenses or attorneys' fees imposed pursuant to Article 11, are a charge on the land and a continuing lien upon the Lot against which each such Assessment or charge is made. Such Assessments, charges, and other costs are also the personal obligation of the Person who was the Owner of such Lot at the time when the Assessment or charge fell due. Such liens and personal obligations will be enforced in the manner set forth in Article 11.

10.12 **Voluntary Conveyance.** In a voluntary conveyance of a Lot the grantee will be jointly and severally liable with the grantor for all unpaid Assessments against the grantor of the Lot up to

the time of the grant or conveyance, without prejudice to the grantee's right to recover from the grantor the amounts paid by the grantee therefor. However, upon request of an Owner or Owner's agent for the benefit of a prospective purchaser, the Board of Directors will make and deliver a written statement of the unpaid Assessments against the prospective grantor of the Lot effective through a date specified in the statement, and the grantee in that case will not be liable for any unpaid Assessments against the grantor not included in the written statement.

10.13 **No Waiver.** Failure of the Board of Directors to fix Assessment amounts or rates or to deliver or mail each Owner an Assessment notice will not be deemed a waiver, modification or release of any Owner from the obligation to pay Assessments. In such event, each Owner will continue to pay Assessments on the same basis as during the last year for which an Assessment was made, if any, until a new Assessment is levied, at which time the Association may retroactively assess any shortfalls in collections.

10.14 **No Option to Exempt.** No Owner may exempt himself or herself from liability for Assessments by nonuse of Common Areas, abandonment of his or her Lot, or any other means. The obligation to pay Assessments is a separate and independent covenant on the part of each Owner. No diminution or abatement of Assessments or set-off may be claimed or allowed for any alleged failure of the Association or Board of Directors to take some action or perform some function required of it, or for inconvenience or discomfort arising from the making of repairs or Improvements, or from any other action it takes.

10.15 **Certificate.** Upon written request, the Association must furnish to any Owner liable for any type of Assessment a certificate in writing signed by an Association officer setting forth whether such Assessment has been paid. Such certificate is conclusive evidence of payment. The Association may require the advance payment of a reasonable processing fee for the issuance of such certificate.

Article 11

ENFORCEMENT

11.1 **Violation of General Protective Covenants.** If an Owner constructs or permits to be constructed on his or her Lot an Improvement contrary to the provisions of this Declaration, or violates any provisions of this Declaration, the Bylaws, or the Rules and Regulations, then the Association acting through the Board of Directors will notify the Owner in writing of any such specific violations. If the Owner is unable, is unwilling, or refuses to comply with the Association's specific directives for remedy or abatement, or the Owner and the Association cannot agree to a mutually acceptable solution within the framework and intent of this Declaration, after notice and opportunity to be heard and within 14 days after issuing written notice to the Owner, then the Association acting through the Board has the right to do any or all of the following:

(a) Assess reasonable fines against such Owner, based upon a resolution adopted by the Board of Directors that is delivered to each Lot, mailed to the mailing address of each Lot or mailed to the mailing address designated by the Owner of each Lot in writing, which fines constitute Individual Assessments for purposes of this Declaration;

(b) Enter the offending Lot and remove the cause of such violation, or alter, repair or change the item that is in violation of this Declaration in such a manner as to make it conform thereto, in which case the Association may assess such Owner for the entire cost of the work done, which amount will be payable to the Operations Fund as an Individual Assessment, provided that no items of construction will be altered or demolished in the absence of judicial proceedings;

(c) Cause any vehicle parked in violation of this Declaration or of the Rules and Regulations to be towed and impounded at the Owner's expense;

(d) Suspend the voting rights, any utility services paid for out of Assessments and the right to use the Common Areas for the period that the violations remain unabated, provided that the Association does not deprive any Owner of access to and from the Owner's Lot in the absence of a lien foreclosure or court order to such effect; and

(e) Bring suit or action against the Owner on behalf of the Association and other Owners to enforce this Declaration.

11.2 Default in Payment of Assessments; Enforcement of Lien. If an Assessment or other charge levied under this Declaration is not paid within 30 days after its due date, such Assessment or charge becomes delinquent and bears interest from the due date at the rate set forth below. In such event the Association may exercise any or all of the following remedies:

(a) The Association may suspend such Owner's voting rights, any utility or communication service paid for out of Assessments and right to use the Common Areas until such amounts, plus other charges under this Declaration, are paid in full, and may declare all remaining periodic installments of any General Assessment immediately due and payable. In no event, however, will the Association deprive any Owner of access to and from the Owner's Lot in the absence of a lien foreclosure or court order to such effect.

(b) The Association has a lien in accordance with ORS 94.709 against each Lot for any Assessment levied against the Lot, including any fines or other charges imposed under this Declaration or the Bylaws against the Owner of the Lot, and may foreclose such lien in the manner provided in ORS 94.709.

(c) The Association may bring an action to recover a money judgment for unpaid Assessments under this Declaration without foreclosing or waiving the lien described in Section 11.2(b). Recovery on any such action, however, operates to satisfy the lien, or the portion thereof, for which recovery is made.

(d) The Association has any other remedy available to it by law or in equity.

11.3 Interest, Late Charges and Expenses. Any amount not paid to the Association when due in accordance with this Declaration bears interest from the due date until paid at a rate that is the greater of 12 percent per annum or such other rate as may be established by the Board of Directors, but not to exceed the lawful rate of interest under the laws of the state of Oregon. A late charge may be charged for each delinquent Assessment in an amount established from time to time by resolution of the Board, which resolution is delivered to each Lot, mailed to the mailing address of each Lot or mailed to the mailing address designated by the Owner in writing, together with all

expenses incurred by the Association in collecting such unpaid Assessments, including attorneys' fees (even if suit is not instituted). In the event the Association files a notice of lien, the lien amount also includes the recording fees associated with filing the notice, and a fee for preparing the notice of lien, established from time to time by resolution of the Board.

11.4 **Costs and Attorneys' Fees.** In the event of any suit or action to enforce this Declaration, the Bylaws, the Rules and Regulations, or the Oregon Planned Community Act, or to collect any money due hereunder or to foreclose a lien, the prevailing party in such suit or act will be entitled to recover all costs and expenses incurred by it in connection with such suit or action, including a foreclosure title report, and will recover such amount as the court may determine to be reasonable as attorneys' fees at trial and upon any appeal or petition for review thereof or in connection with any bankruptcy proceedings or special bankruptcy remedies.

11.5 **Assignment of Rents.** As security for the payment of all obligations owing to the Association pursuant to this Section 11.5, each Owner hereby grants to the Association the right to collect the rents, issues and profits of the Owner's Lot; provided, however, that the Owner will retain the right, prior to any default by such Owner in performance of the Owner's obligations under this Declaration, to collect and retain such rents, issues and profits as they become due and payable. Upon any such default, the Association may, at any time after 10 days written notice to the Owner, either in person, by agent or by a receiver to be appointed by a court of competent jurisdiction, and without regard to the adequacy of any security for such indebtedness, in its own name sue for or otherwise collect such rents, issues and profits, including those past due and unpaid, and apply them, less costs and expenses of operation and collection, including reasonable attorneys' fees, in payment of such indebtedness to the Association, and in such order as the Association may determine. Such action will not cure nor waive any default under this Declaration or invalidate any act done pursuant to this Declaration. The assignment of rents and powers described in this Section 11.5 does not affect, and will in all respects be subordinated to, the rights and powers of the holder of any first or second Mortgage on any Lot to do the same or similar acts

11.6 **Nonexclusiveness and Accumulation of Remedies.** An election by the Association to pursue any remedy provided for violation of this Declaration will not prevent concurrent or subsequent exercise of another remedy permitted under this Declaration. The remedies provided in this Declaration are not exclusive but are in addition to all other remedies, including actions for damages and suits for injunctions and specific performance, available under applicable law to the Association. In addition, any aggrieved Owner may bring an action against another Owner or the Association to recover damages or to enjoin, abate, or remedy any violation of this Declaration by appropriate legal proceedings.

11.7 **Enforcement by Clackamas County.** The provisions of this Declaration relating to preservation and maintenance of Common Areas will be deemed to be for the benefit of Clackamas County as well as the Association and Owners of Lots, and Clackamas County may enforce such provisions by appropriate proceedings at law or in equity, or may cause such maintenance to be performed, the costs of which will become a lien upon the Property.

Article 12

DISPUTE RESOLUTION

12.1 Mediation.

(a) Except as otherwise provided in this Section 12.1, before initiating litigation, arbitration, or an administrative proceeding in which the Association and an Owner have an adversarial relationship, the party that intends to initiate litigation, arbitration or an administrative proceeding will offer to use any dispute resolution program available within Clackamas County, Oregon that is in substantial compliance with the standards and guidelines adopted under ORS 36.175. The written offer must be hand-delivered or mailed by certified mail, return receipt requested, to the address, contained in the records of the Association, for the other party.

(b) If the party receiving the offer does not accept the offer within 10 days after receipt of the offer, such acceptance to be made by written notice, hand-delivered or mailed by certified mail, return receipt requested, to the address, contained in the records of the Association, for the other party, the initiating party may commence the litigation, arbitration or administrative proceeding. The notice of acceptance of the offer to participate in the program must contain the name, address, and telephone number of the body administering the dispute resolution program.

(c) If a qualified dispute resolution program exists within Clackamas County, Oregon and an offer to use the program is not made as required under Section 12.1(a), then litigation, arbitration or an administrative proceeding may be stayed for 30 days upon a motion of the noninitiating party. If the litigation, arbitration or administrative action is stayed under this Section 12.1(c), both parties must participate in the dispute resolution process.

(d) Unless a stay has been granted under Section 12.1(c), if the dispute resolution process is not completed within 30 days after receipt of the initial offer, the initiating party may commence litigation, arbitration or an administrative proceeding without regard to whether the dispute resolution is completed.

(e) Once made, the decision of the court, arbitrator or administrative body arising from litigation, arbitration or an administrative proceeding may not be set aside on the grounds that an offer to use a dispute resolution program was not made.

(f) The requirements of this Section 12.1 do not apply to circumstances in which irreparable harm to a party will occur due to delay or to litigation, arbitration, or an administrative proceeding initiated to collect Assessments, other than Assessments attributable to fines.

12.2 Arbitration. Any claim, controversy or dispute by or among Declarant (including members, officers, directors, shareholders and affiliates of Declarant), Association, the Architectural Review Committee, or one or more Owners, or any of them, arising out of or related to this Declaration, the Bylaws, the Rules and Regulations, or the Property will be first subject to mediation as described in Section 12.1 or otherwise, and if not timely settled by mediation will be resolved by arbitration in accordance with this Article 12. The decisions and award of the arbitrator are final, binding and nonappealable. The arbitration will be conducted in the Portland, Oregon, metropolitan area or at such other location as may be agreed upon by the parties, pursuant to the arbitration statutes

of the state of Oregon, and any arbitration award may be enforced by any court with jurisdiction. Filing for arbitration will be treated the same as filing in court for purposes of meeting any applicable statute of limitations or for purposes of filing a notice of pending action ("lis pendens").

12.3 **Selection of Arbitrator.** The arbitration will be conducted by a single arbitrator selected by mutual agreement of the parties. The arbitrator selected must be neutral and unbiased, except to the extent the arbitrator's prior relationship with any party is fully disclosed and consented to by the other party or parties. If the parties are unable to agree upon the arbitrator within 10 days after a party's demand for arbitration, upon application of any party, the presiding judge of the Circuit Court of Clackamas County, Oregon will designate the arbitrator.

12.4 **Consolidated Arbitration.** Upon demand by any party, claims between or among the parties and third parties will be submitted in a single, consolidated arbitration. Notwithstanding the provisions of this Article 12, in the event any claim, controversy or dispute involves a claim by either party against a third party who is not required to and does not voluntarily agree to submit such claim to arbitration, then either party may elect to have the matter determined by a court of law in a consolidated proceeding, rather than by arbitration. In such case, the parties hereby waive trial by jury and agree that the matter will be determined by a judge sitting without a jury.

12.5 **Discovery.** The parties to the arbitration are entitled to such discovery as would be available to them in an action in Clackamas County Circuit Court. The arbitrator has all of the authority of the court incidental to such discovery, including, without limitation, authority to issue orders to produce documents or other materials, to issue orders to appear and submit to deposition, and to impose appropriate sanctions, including, without limitation, award against a party for failure to comply with any order.

12.6 **Evidence.** The parties to the arbitration may offer such evidence as they desire and will produce such additional evidence as the arbitrator may deem necessary for an understanding and determination of the dispute. The arbitrator will determine the admissibility of the evidence offered. All evidence will be taken in the presence of the arbitrator and all of the parties, except when any of the parties is absent in default or has waived its right to be present.

12.7 **Excluded Matters.** Notwithstanding the foregoing, the following matters are not subject to mediation or arbitration under this Article 12 (but are subject to the applicable provisions of Section 12.8): (a) actions relating to the collection of fees, Assessments, fines and other charges imposed or levied by the Association (other than disputes as to the validity or amount of such fees, Assessments, fines or charges, which disputes will be subject to mediation/arbitration as provided above); and (b) actions to enforce any order, decision or award rendered by arbitration pursuant to this Article 12. The filing of a lis pendens or the application to any court for the issuance of any provisional process or similar remedy described in the Oregon or Federal Rules of Civil Procedure will not constitute a waiver of the right or duty to utilize the procedures specified in this Article 12.

12.8 **Costs and Attorneys' Fees.** The fees of any mediator and the costs of mediation will be divided and paid equally by the parties. Each party will pay its own attorneys' fees and costs in connection with any mediation. The fees of any arbitrator and the costs of arbitration will be paid by the nonprevailing party or parties; if none, such fees and costs will be divided and paid equally by the parties. Should any suit, action or arbitration be commenced in connection with any dispute related to or arising out of this Declaration, the Bylaws, the Rules and Regulations, or the Oregon Planned

Community Act to obtain a judicial construction of any provision of this Declaration, the Bylaws or the Rules and Regulations; to rescind this Declaration; or to enforce or collect any judgment or decree of any court or any award obtained during arbitration, the prevailing party will be entitled to recover its costs and disbursements, together with such investigation, expert witness and attorneys' fees incurred in connection with such dispute as the court or arbitrator may adjudge reasonable, at trial, in the arbitration, upon any motion for reconsideration, upon petition for review, and on any appeal of such suit, action or arbitration proceeding. The determination of who is the prevailing party and the amount of reasonable attorneys' fees to be paid to the prevailing party will be decided by the arbitrator (with respect to attorneys' fees incurred before and during the arbitration proceeding) and by the court or courts, including any appellate or review court, in which such matter is tried, heard or decided, including a court that hears a request to compel or enjoin arbitration or that hears exceptions made to an arbitration award submitted to it for confirmation as a judgment (with respect to attorneys' fees incurred in such proceedings).

12.9 **Survival.** The mediation and arbitration agreement set forth in this Article 12 will survive the transfer by any party of its interest or involvement in the Property and any Lot therein and will survive the termination of this Declaration.

Article 13

MORTGAGEES

The following provisions are for the benefit of holders, insurers and guarantors of first Mortgage on Lots. The provisions of this Article 13 apply to both this Declaration and to the Bylaws, notwithstanding any other provisions contained therein.

13.1 **Subordination of Lien to Mortgages.** The lien of the Assessments or charges provided for in this Declaration are subordinate to the lien of any Mortgage on such Lot which was made in good faith and for value and which was recorded prior to the recordation of the notice of lien. Sale or transfer of any Lot does not affect the Assessment lien, but the sale or transfer of any Lot that is subject to any Mortgage or deed of trust pursuant to a decree of foreclosure or nonjudicial sale thereunder extinguishes any lien of an Assessment, notice of which was recorded after the recording of the Mortgage. Such sale or transfer, however, does not release the Lot from liability for any Assessments or charges thereafter becoming due or from the lien of such Assessments or charges.

13.2 **Reimbursement of First Mortgagees.** First Mortgagees of Lots may, jointly or singly, pay taxes or other charges which are in default and which may or have become a charge against any Common Areas and may pay overdue premiums on hazard insurance policies or secure new hazard insurance coverage on the lapse of a policy, for such Common Area. First Mortgagees making such payments are owed immediate reimbursement therefor from the Association.

13.3 **Notification of First Mortgagee.** If a first Mortgagee has requested such notice in writing from the Association, the Board will notify such Mortgagee of any individual Lot of any default in performance of this Declaration by the Owner which is not cured within 60 days after notice of default to the Owner.

13.4 **Notice to Association.** Upon request, each Owner is obligated to furnish to the Association the name and address of the holder of any Mortgage encumbering such Owner's Lot.

Article 14

AMENDMENT AND REPEAL

14.1 **How Proposed.** Amendments to or repeal of this Declaration will be proposed by either a majority of the Board of Directors or by Owners holding 30 percent or more of the Association's voting rights. The proposed amendment or repeal must be reduced to writing and will be included in the notice of any meeting at which action is to be taken thereon or attached to any request for consent to the amendment or repeal.

14.2 **Approval Required.** This Declaration, or any provision thereof, as from time to time in effect with respect to all or any part of the Property, may be amended or repealed by the vote or written consent of Owners representing not less than 75 percent of the voting rights, without regard to any weighted vote for the Class B Member, together with the written consent of the Class B Member, if such Class B Membership has not been terminated as provided in this Declaration. In no event will an amendment under this section create, limit or diminish special Declarant rights without Declarant's written consent, or change the boundaries of any Lot or any uses to which any Lot is restricted under this Declaration or change the method of determining liability for common expenses, the method of determining the right to common profits or the method of determining voting rights of any Lot unless the Owners of the affected Lots unanimously consent to the amendment. Declarant may not amend this Declaration to increase the scope of special Declarant rights reserved in this Declaration after the sale of the first Lot unless Owners representing 75 percent of the total vote, other than Declarant, agree to the amendment. To the extent any amendment relates to the preservation or maintenance of the Common Areas or private utility lines, a City of Wilsonville Development Agreement, or the existence of an entity responsible for accomplishing the same, such amendment must be approved by the planning department of City of Wilsonville.

14.3 **Recordation.** Any such amendment or repeal becomes effective only upon recordation in the Deed Records of Clackamas County, Oregon of a certificate of the president and secretary of the Association setting forth in full the amendment, amendments or repeal so approved and certifying that such amendment, amendments or repeal have been approved in the manner required by this Declaration and ORS 94.590, and acknowledged in the manner provided for acknowledgment of deeds.

14.4 **Regulatory Amendments.** Notwithstanding the provisions of Section 14.2, until the Turnover Meeting has occurred, Declarant has the right to amend this Declaration or the Bylaws of the Association to comply with the requirements of the Federal Housing Administration; the United States Department of Veterans Affairs; the Farmers Home Administration of the United States; the Federal National Mortgage Association; the Government National Mortgage Association; the Federal Home Mortgage Loan Corporation; any department, bureau, board, commission or agency of the United States or the state of Oregon; or any corporation wholly owned, directly or indirectly, by the United States or the state of Oregon that insures, guarantees or provides financing for a planned community or lots in a planned community. After the Turnover Meeting, any such amendment must be approved by the Association in accordance with the approval provisions of this Declaration or the Bylaws, as applicable.

Article 15

MISCELLANEOUS PROVISIONS

15.1 **No Implied Obligations.** Nothing in this Declaration may be construed to require Declarant or any successor Declarant to subject Additional Property to this Declaration or to improve or develop any of the Property or to do so for any particular uses.

15.2 **Right to Approve Additional Covenants.** No Person may record any declaration of covenants, conditions and restrictions, declaration of condominium or similar instrument affecting any portion of the Property without Declarant's prior written consent. Any attempted recordation without such consent will result in such instrument being void and of no force or effect unless subsequently approved in writing by Declarant.

15.3 **Notice of Sale or Transfer of Title.** Any Owner selling or otherwise transferring title to his or her Lot must give the Association written notice within seven days after the transfer of the name and address of the purchaser or transferee, the date of such transfer of title and such other information as the Association may reasonably require. The transferor continues to be jointly and severally responsible with the transferee for all obligations of the Owner of the Lot, including Assessment obligations, until the date upon which such notice is received by the Board, notwithstanding the transfer of title.

15.4 **Exclusive Rights to Use Name of Development.** No Person may use the name "Stafford Meadows" or any derivative of such name in any printed, digital (i.e., internet) or other promotional or commercial material without Declarant's prior written consent. However, an Owner may use the name "Stafford Meadows" where such term is used solely to specify that the Owner's property is located within the Property. In no event will any Owner enter into an agreement with any third party for the sale, rental, or management of the Owner's Lot if such agreement purports to grant any right to such third party to use the name "Stafford Meadows" or any derivative of such name in violation of this provision.

15.5 **Lessees and Other Invitees.** Lessees, employees, invitees, licensees, contractors, family members, guests, and other Persons entering the Property under rights derived from an Owner must comply with all of the provisions of this Declaration restricting or regulating the Owner's use, improvement or enjoyment of his or her Lot and other areas within the Property. The Owner is responsible for obtaining such compliance and will be liable for any failure of compliance by such Persons in the same manner and to the same extent as if the failure had been committed by the Owner.

15.6 **Nonwaiver.** Failure by the Association or by any Owner to enforce any covenant or restriction contained in this Declaration will in no event be deemed a waiver of the right to do so thereafter.

15.7 **Construction and Severability.** This Declaration will be liberally construed as an entire document to accomplish the purposes hereof as stated in the introductory paragraphs hereof. Nevertheless, each provision of this Declaration will be deemed independent and severable, and the invalidity or partial invalidity of any provision will not affect the validity or enforceability of the remaining part of that or any other provision.

15.8 **Terminology and Captions.** As used in this Declaration, the singular includes the plural and the plural the singular, and the masculine and neuter each include the masculine, feminine and neuter, as the context requires. All captions used in this Declaration are intended solely for convenience of reference and in no way limit any of the provisions of this Declaration.

15.9 **Notices.** All notices to the Association or to the Board of Directors will be sent care of the manager or, if there is no manager, to the principal office of the Association or to such other address as the Board may designate from time to time. All notices to any Owner will be sent to such address as may have been designated by such Owner from time to time, in writing, to the Board or, if no address has been designated, to the Owner's Lot. In the discretion of the Board, any notice, information or other written material required to be given to an Owner or director under this Declaration or the Bylaws or pursuant to the Oregon Planned Community Act, may be given by electronic mail, facsimile or other form of electronic communication acceptable to the Board, except for the following notices: failure to pay an Assessment, foreclosure of an Association lien under ORS 94.709, or an action the Association may take against an Owner. An Owner or director may decline to receive notice by electronic mail, facsimile or other form of electronic communication and may direct the Board to provide notice in any other manner permitted under this Declaration or the Bylaws or the Oregon Planned Community Act.

15.10 **Private Agreement.** This Declaration and the covenants and agreements contained herein constitute a private agreement among the Owners of Lots in Stafford Meadows. This Declaration does not restrict City of Wilsonville's authority to adopt or amend its development regulations. It is the duty of every Person engaged in development or remodeling of a Lot and/or Improvement in Stafford Meadows to know the requirements of this Declaration and the covenants

and agreements contained herein. There may be conflicting requirements between this Declaration and regulations of City of Wilsonville. In the event there is a conflict between a regulation of City of Wilsonville and this Declaration, any question regarding which provision controls will be directed to the Architectural Review Committee. In each case, Clackamas County will limit its review of a development application to the requirements of its regulations and will not be liable for any approvals or permits that are granted in compliance with the regulations of City of Wilsonville, Clackamas County, the state of Oregon or any other jurisdiction, but that are not in compliance with this Declaration. Declarant, the Committee and the Association, or any one of them, will not be liable for any approvals that are granted in compliance with this Declaration, but that are not in compliance with the regulations of City of Wilsonville, Clackamas County, the State of Oregon or any other jurisdiction.

IN WITNESS WHEREOF, Declarant has executed this Declaration on the date set forth above.

WEST HILLS LAND DEVELOPMENT LLC,
an Oregon limited liability company



Walter E. Remmers, Member

STATE OF OREGON)
)ss.
COUNTY OF Multnomah)

The foregoing instrument was acknowledged before me this 12th day of December, 2018, by Walter E. Remmers, member of West Hills Land Development LLC, an Oregon limited liability company, on its behalf.

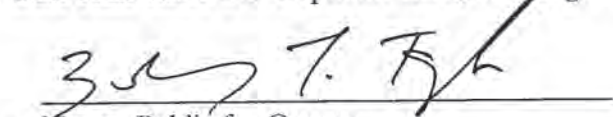
Notary Public for Oregon
My commission expires: March 01, 2022

23P
AFTER RECORDING RETURN TO:

Michelle D. Da Rosa LLC
Attorney at Law
205 SE Spokane Street, Suite 300
Portland, OR 97202
Zachary Taylor

Clackamas County Official Records
Sherry Hall, County Clerk

2019-002824



\$203.00

01/17/2019 12:56:31 PM

PD-BYL Cnt=1 Stn=54 COUNTER2
\$115.00 \$16.00 \$62.00 \$10.00

BYLAWS OF STAFFORD MEADOWS HOMEOWNERS ASSOCIATION

Attached hereto are the initial Bylaws of Stafford Meadows Homeowners Association adopted January 18, 2019 by the Declarant pursuant to the Declaration of Protective Covenants, Conditions, Restrictions and Easements for Stafford Meadows recorded 1/15, 2019 in the Records of ~~Washington~~ Clackamas County, Oregon, as Document No. 2019-002161.

WEST HILLS LAND DEVELOPMENT LLC,
an Oregon limited liability company

By: 
Walter E. Remmers, member

Address: 3330 NW Yeon, Suite 200
Portland, OR 97210

STATE OF OREGON)
)ss.
COUNTY of Multnomah)

This instrument was acknowledged before me this 12th day of December, 2018, by Walter E. Remmers, member of West Hills Land Development LLC, an Oregon limited liability company, on its behalf.

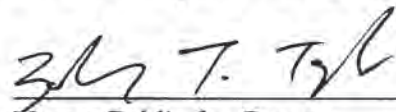

Notary Public for Oregon
My commission expires March 1, 2022

**BYLAWS OF
STAFFORD MEADOWS HOMEOWNERS ASSOCIATION**

TABLE OF CONTENTS

	Page
Article 1 DEFINITIONS	1
1.1 Association	1
1.2 Articles of Incorporation	1
1.3 Declaration	1
1.4 Incorporation by Reference	1
Article 2 MEMBERSHIP	1
2.1 Membership	1
2.2 Membership List	1
Article 3 MEETINGS AND VOTING	1
3.1 Place of Meetings	1
3.2 Turnover Meeting	1
3.3 Annual Meeting	2
3.4 Special Meetings	2
3.5 Notice of Meeting	2
3.6 Quorum	2
3.7 Voting Rights	3
3.8 Fiduciaries and Joint Owners	3
3.9 Tenants and Contract Vendors	3
3.10 Casting of Votes and Consents	4
3.11 Majority Vote	4
3.12 Rules of Order	4
Article 4 DIRECTORS: MANAGEMENT	5
4.1 Number and Qualification	5
4.2 Interim Directors	5
4.3 Transitional Advisory Committee	5
4.4 Election and Tenure of Office	5
4.5 Vacancies	6
4.6 Removal of Directors	6
4.7 Powers	6
4.8 Meetings	8
4.9 Open Meetings	8
4.10 Notice of Meetings	9
4.11 Quorum and Vote	9
4.12 Right Of Declarant To Disapprove Actions	9
4.13 Liability	10
4.14 Compensation	10
4.15 Executive, Covenants and Other Committees	10
4.16 Enforcement Procedures	11
Article 5 OFFICERS	12
5.1 Designation and Qualification	12
5.2 Election and Vacancies	12
5.3 Removal and Resignation	12
5.4 President	12
5.5 Vice Presidents	12

5.6	Secretary.....	12
5.7	Treasurer.....	13
5.8	Compensation of Officers.	13
Article 6	ASSESSMENTS, RECORDS AND REPORTS.....	13
6.1	Assessments.	13
6.2	Records.	14
6.3	Statement of Assessments Due.....	14
6.4	Inspection of Books and Records.	15
6.5	Payment of Vouchers.	15
6.6	Execution of Documents.....	15
6.7	Reports and Audits.	15
Article 7	INSURANCE.....	16
7.1	Types of Insurance.....	16
7.2	Insurance by Lot Owners.	17
7.3	Planned Community Act Requirements.	17
Article 8	GENERAL PROVISIONS.....	17
8.1	Seal.....	17
8.2	Notice.....	17
8.3	Waiver of Notice.....	18
8.4	Action Without Meeting.	18
8.5	Conflicts.....	18
Article 9	AMENDMENTS TO BYLAWS.....	18
9.1	How Proposed.....	18
9.2	Adoption.....	18
9.3	Execution and Recording.....	19

BYLAWS OF
STAFFORD MEADOWS HOMEOWNERS ASSOCIATION

Article 1

DEFINITIONS

1.1 **Association.** "Association" means Stafford Meadows Homeowners Association, a nonprofit corporation organized and existing under the laws of the State of Oregon.

1.2 **Articles of Incorporation.** "Articles of Incorporation" means the Articles of Incorporation of the Association.

1.3 **Declaration.** The "Declaration" means the recorded Declaration of Protective Covenants, Conditions, Restrictions and Easements for Stafford Meadows, as the same may be subsequently amended or supplemented pursuant to the terms thereof.

1.4 **Incorporation by Reference.** Except as otherwise provided herein, the terms that are defined in Article 1 of the Declaration are used in these Bylaws as therein defined.

Article 2

MEMBERSHIP

2.1 **Membership.** Every Owner of one or more Lots within the Property will, immediately upon creation of the Association and thereafter during the entire period of such ownership, be a member of the Association. Such membership commences, exists and continues simply by virtue of such ownership, expires automatically upon termination of such ownership, and need not be confirmed or evidenced by any certificate or acceptance of membership. The Association has two classes of membership, Class A and Class B, as set forth in the Declaration.

2.2 **Membership List.** The Secretary will maintain at the principal office of the Association a membership list showing the name and address of the Owner of each Lot. The Secretary may accept as satisfactory proof of such ownership a duly executed and acknowledged conveyance, a title insurance policy, or other evidence reasonably acceptable to the Board of Directors.

Article 3

MEETINGS AND VOTING

3.1 **Place of Meetings.** Meetings of the members of the Association will be held at such reasonable place convenient to the members as may be designated in the notice of the meeting

3.2 **Turnover Meeting.** Declarant will call the first meeting of the Owners to organize the Association within 90 days after termination of the Class B Membership as provided in Section

3.7 below. Notice of such meeting will be given to all Owners as provided in Section 3.5. If a quorum of the Owners is present, the Owners will elect not fewer than the number of directors sufficient to constitute a quorum of the Board of Directors. If the Declarant fails to call the meeting, the meeting may be called and notice given by any Owner or Mortgagee of a Lot. The expense of giving notice will be paid or reimbursed by the Association. In the event of a lack of quorum at such Turnover Meeting, it may be adjourned as provided in Section 3.6. Nothing in this section may be construed as preventing Declarant from calling the Turnover Meeting before such date or from calling informal, informational meetings of the Owners.

3.3 **Annual Meeting.** The annual meeting of the members for the election of directors and for the transaction of such other business as may properly come before the meeting will be held at a reasonable hour and on a reasonable day as may be established by the Board of Directors or, if the Board fail to designate a date by the first day of September, then at 7:30 p.m. on the second Thursday in October. The first annual meeting will be held within one year after the date of the Turnover Meeting.

3.4 **Special Meetings.** A special meeting of the Association may be called at any time by the President or by a majority of the Board of Directors. A special meeting will be called by the president or secretary upon receipt of a written request stating the purpose of the meeting from members having at least 30 percent of the voting rights entitled to be cast at such meeting. Business transacted at a special meeting will be confined to the purposes stated in the notice of meeting.

3.5 **Notice of Meeting.**

(a) Written or printed notice stating the place, day and hour of the meeting, the items on the agenda, including the general nature of any proposed amendment to the Declaration or these Bylaws, any budget changes, any proposal to remove a director or officer and, in case of a special meeting, the purpose or purposes for which the meeting is called, will be delivered not less than 10 or more than 50 days before the date of the meeting. Such notice will be given either personally, by mail or, to the extent permitted by law, by electronic mail, facsimile or other form of electronic communication acceptable to the Board of Directors, by or at the direction of the President, the Secretary, or the persons calling the meeting, to each member entitled to vote at such meeting and to all Mortgagees who have requested such notice. For a period of 10 years following recording of the Declaration, notices of meetings (including agendas) must also be given to Declarant (or any designee of Declarant specified in any written notice to the Association) in the same manner as given to Owners, and Declarant or a representative of Declarant will be entitled to attend such meetings. If mailed, such notice will be deemed to be delivered when deposited in the United States mail, with postage fully prepaid thereon, addressed to the member at his or her most recent address as it appears on the records of the Association or to the mailing address of his or her Lot.

(b) When a meeting is adjourned for 30 days or more, or when a redetermination of the Persons entitled to receive notice of the adjourned meeting is required by law, notice of the adjourned meeting will be given as for an original meeting. In all other cases, no notice of the adjournment or of the business to be transacted at the adjourned meeting need be given other than by announcement at the meeting at which such adjournment is taken.

3.6 **Quorum.** At any meeting of the Association, members having at least 25 percent of the voting rights entitled to be cast at such meeting, present in person, by proxy or by absentee ballot,

if permitted by the Board of Directors, constitutes a quorum, except when a larger quorum is required by the Declaration. When a quorum is once present to organize a meeting, it cannot be broken by the subsequent withdrawal of a member or members. If any meeting of members cannot be organized because of a lack of quorum, the members who are present, either in person or by proxy, may adjourn the meeting from time to time not less than 48 hours or more than 30 days from the time the original meeting was called until a quorum is present, in which case, at the re-scheduled meeting at least 10 percent of the voting rights entitled to be cast at such meeting, present in person, or by proxy, or by absentee ballot (if permitted by the Board of Directors) will constitute a quorum, or half the number of a larger quorum required by the Declaration. If the notice of a meeting of the Association provided that if the meeting fails to meet the 25%-quorum requirement then the quorum will be reduced to 10 percent, then a meeting may continue with a quorum of 10 percent of the voting rights entitled to be cast at such meeting are present in person, or by proxy, or by absentee ballot (if permitted by the Board of Directors).

3.7 **Voting Rights.** The Association has two classes of voting membership:

Class A. Class A Members are all Owners with the exception of the Class B Member and is entitled to one vote for each Lot owned. When more than one Person holds an interest in any Lot, all such Persons will be members. The vote for such Lot is exercised as they among themselves determine, but in no event will more than one vote be cast with respect to any Lot.

Class B. The Class B Member is the Declarant, who is entitled to three votes for each Lot owned by Declarant. The Class B Membership ceases and is converted to Class A Membership on the happening of either of the following events, whichever occurs earlier:

(1) When all of the Lots in the final phase of development of Stafford Meadows have been Sold and conveyed to Owners other than a successor Declarant; or

(2) At such earlier time as Declarant may elect in writing to terminate Class B Membership.

3.8 **Fiduciaries and Joint Owners.** An attorney-in-fact, executor, administrator, guardian, conservator or trustee may vote or grant consent with respect to any Lot owned or held in a fiduciary capacity, whether or not the specific right has been transferred to his or her name; provided that such Person satisfies the Secretary that he or she is the attorney-in-fact, executor, administrator, guardian, conservator or trustee, holding such Lot in a fiduciary capacity. Whenever any Lot is owned by two or more Persons jointly, according to the records of the Association, the vote of such Lot may be exercised by any one of the Owners, in the absence of protest by a co-Owner. In the event of disagreement among the co-Owners, the vote of such Lot will be disregarded completely in determining the proportion of votes given with respect to such matter, unless a valid court order establishes the authority of a co-Owner to vote.

3.9 **Tenants and Contract Vendors.** Unless otherwise expressly stated in the rental agreement or lease, all voting rights allocated to a Lot are exercised by the Owner. Unless otherwise stated in the contract, all voting rights allocated to a Lot are exercised by the vendee of any recorded land sale contract on the Lot.

3.10 **Casting of Votes and Consents.** The voting rights or consent of an Owner may be cast in person at a meeting of the Association or, at the discretion of the Board of Directors, by proxy in accordance with paragraph (a) of this Section, by absentee ballot in accordance with paragraph (b) of this Section, by written ballot in accordance with paragraph (c) of this Section, or by any other method specified in the Declaration, these Bylaws or the Oregon Planned Community Act.

(a) **Proxies.** A proxy must be dated and signed by the Owner and it is not valid if it is undated or purports to be revocable without notice; such proxy terminates one year after its date unless the proxy specifies a shorter term. The Board of Directors may not require that a proxy be on a form prescribed by the Board. An Owner may not revoke a proxy given pursuant to this paragraph except by actual notice of revocation to the person presiding over a meeting of the Association or to the Board if a vote is being conducted by written ballot in lieu of a meeting. A copy of a proxy in compliance with this paragraph provided to the Association by facsimile, electronic mail or other means of electronic communication utilized by the Board is valid.

(b) **Absentee Ballots.** An absentee ballot, if authorized by the Board of Directors, will set forth each proposed action and provide an opportunity to vote for or against each proposed action. All solicitations for votes by absentee ballot must include instructions for delivery of the completed absentee ballot, including the delivery location and instructions about whether the ballot may be canceled if the ballot has been delivered according to the instructions. An absentee ballot will be counted as an Owner present for the purpose of establishing a quorum. Even if an absentee ballot has been delivered to an Owner, the Owner may vote in person at a meeting if the Owner has returned the absentee ballot and canceled the absentee ballot, if cancellation is permitted in the instructions given under this paragraph.

(c) **Ballot Meetings.** At the discretion of the Board of Directors, any action that may be taken at any annual, regular or special meeting of the Association may be taken without a meeting by written ballot to the extent and in the manner provided in ORS 94.647

(d) **Electronic Ballots.** To the extent authorized by the Board of Directors and permitted by the Oregon Planned Community Act, any vote, approval or consent of an owner may be given by electronic ballot.

(e) **Mortgages.** An Owner may pledge or assign such Owner's voting rights to a Mortgagee. In such a case, the Mortgagee or its designated representative will be entitled to receive all notices to which the Owner is entitled under these Bylaws and to exercise the Owner's voting rights from and after the time that the Mortgagee will give written notice of such pledge or assignment to the Board of Directors. Any first Mortgagee may designate a representative to attend all or any meetings of the Association.

3.11 **Majority Vote.** The vote of a majority of the voting rights entitled to be cast by the members present or represented by absentee ballot or proxy, at a meeting at which a quorum is present, is necessary for the adoption of any matter voted upon by the members, unless a greater proportion is required by law, by the Declaration, by the Articles of Incorporation, or by these Bylaws.

3.12 **Rules of Order.** Unless other rules of order are adopted by resolution of the Association or the Board of Directors, all meetings of the Association are to be conducted according to the latest edition of *Robert's Rules of Order*, published by Robert's Rules Association.

Article 4

DIRECTORS: MANAGEMENT

4.1 **Number and Qualification.** The affairs of the Association will be governed by a Board of Directors of three or five individuals. All directors, other than interim directors appointed by Declarant, must be Owners or co-Owners of Lots. For purposes of this section, an officer, employee or agent of a corporation, a member, manager, employee or agent of a limited liability company, or a partner, employee or agent of a partnership may serve on the Board if such corporation, limited liability company or partnership is an Owner or co-Owner of a Lot. In addition, a trustee may serve on the Board if the trustee holds legal title to a Lot for the benefit of the owner of the beneficial interest in the Lot; and an executor, administrator, guardian, conservator or other individual appointed by a court to serve in a fiduciary capacity for an Owner of a Lot, or an officer or employee of an entity if an entity is appointed, may serve on the Board.

4.2 **Interim Directors.** Upon the recording of the Declaration, Declarant will appoint an interim board of one to three directors, who serve until replaced by Declarant or until their successors have been replaced by the Owners as provided below.

4.3 **Transitional Advisory Committee.** Unless the Turnover Meeting has already been held, Declarant will call a meeting of the Owners for the purpose of forming a Transitional Advisory Committee. The meeting must be called within 60 days after the date Declarant conveys 50 percent or more of the Lots then existing in Stafford Meadows to Owners other than a successor Declarant. The committee will consist of two or more Owners elected by the Owners other than Declarant and not more than one representative of Declarant. The members serve until the Turnover Meeting. The Transitional Advisory Committee is advisory only, and its purpose is to enable ease of transition from administrative control of the Association by Declarant to control by the Owners. The committee will have access to any information, documents and records that Declarant must turn over to the Owners at the time of the Turnover Meeting. If Declarant fails to call the meeting to elect a Transitional Advisory Committee within the time specified, the meeting may be called and notice given by any Owner. If the Owners fail to elect a Transitional Advisory Committee at the meeting called for such purpose, Declarant will have no further obligation to form the committee.

4.4 **Election and Tenure of Office.**

(a) At the Turnover Meeting, the interim directors will resign and the members will elect three directors, two to serve for two years and one to serve for one year. The nominees receiving the greatest number of votes serve for two years. In the event of a tie, term selection will be by random means. Thereafter, the successors to each director serve for terms of two years each.

(b) Upon a majority vote of the voting rights entitled to be cast by the members present or represented by absentee ballot or proxy at a meeting or ballot meeting at which a quorum is present, the Board of Directors may be increased from three directors to five directors. At the next annual meeting or a special meeting called for such purpose, two additional directors will be elected, one to serve for a two-year term and one to serve for a one-year term. Term selection will be in the same manner as provided in paragraph (a) above.

(c) All directors hold office until their respective successors have been elected by the members. Election is by plurality.

4.5 **Vacancies.**

(a) A vacancy in the Board of Directors will exist upon the death, resignation or removal of any director, or if the authorized number of directors is increased, or if the members fail at any annual or special meeting of members at which any director or directors are to be elected to elect the full authorized number of directors to be voted for at that meeting.

(b) Vacancies in the Board of Directors caused by any reason other than the removal of a director by a vote of the Association will be filled by vote of the majority of the remaining directors, even though they may constitute less than a quorum, or by a sole remaining director. Each person so elected will serve as a director until a successor is elected to fill the unexpired term at the next annual meeting of the Association or the next special meeting of the Association called for that purpose. Vacancies in interim directors are filled by Declarant.

4.6 **Removal of Directors.** At any regular or special meeting of the Association duly called, any one or more of the directors, other than interim directors, may be removed with or without cause by a majority vote of the members present in person or by proxy, and a successor may be elected at that meeting to fill the vacancy thus created. The members must vote on the removal of each director separately. The notice and agenda of any such meeting will state that such removal is to be considered, and any director whose removal has been proposed must be given an opportunity to be heard at that meeting and prior to the vote. A removed director remains a director until the vacancy has been filled.

4.7 **Powers.** The Board of Directors has all the powers and duties necessary for the administration of the affairs of the Association, except such powers and duties as by law or by the Declaration or by these Bylaws may not be delegated to the Board by the Owners. The Board may delegate responsibilities to committees or a managing agent but must retain ultimate control and supervision. The powers and duties to be exercised by the Board include, but not be limited to, those set forth in Section 8.5 of the Declaration and the following:

(a) Carry out the program for maintenance, upkeep, repair and replacement of any property required to be maintained by the Association as described in the Declaration and these Bylaws.

(b) Determine the amounts required for operation, maintenance and other affairs of the Association, and the making of such expenditures.

(c) Prepare a budget for the Association, and assessment and collection of the Assessments.

(d) Employ and dismiss such personnel as may be necessary for such maintenance, upkeep and repair.

(e) Employ legal, accounting or other personnel for reasonable compensation to perform such services as may be required for the proper administration of the Association; provided,

however, the Board of Directors may not incur or commit the Association to incur legal fees in excess of \$5,000 for any specific litigation or claim matter or enter into any contingent fee contract on any claim in excess of \$100,000 unless the Owners have enacted a resolution authorizing the incurring of such fees by a vote of 75 percent of the total voting rights. These limitations are not applicable to legal fees incurred in defending the Association or the Board from claims or litigation brought against them. The limitations set forth in this paragraph will increase by ten percent on each fifth anniversary of the recording of the Declaration. To the extent required by the Oregon Planned Community Act, the Board will notify the Owners before instituting litigation or administrative proceedings. With regard to any pending litigation involving the Association, the Board will periodically report to the Owners the status (including settlement offers), progress and method of funding such litigation. Nothing in this paragraph may be construed as requiring the Board to disclose any privileged communication between the Association and its counsel.

(f) Open bank accounts on behalf of the Association and designating the signatories required therefor.

(g) Prepare and file, or cause to be prepared and filed, any required income tax returns or forms for the Association.

(h) Purchase Lots at foreclosure or other judicial sales in the name of the Association or its designee.

(i) Sell, lease, mortgage, vote the votes appurtenant to (other than for the election of directors), or otherwise deal with Lots acquired by the Association or its designee.

(j) Obtain insurance or bonds pursuant to the provisions of these Bylaws and review such insurance coverage at least annually.

(k) Make additions and improvements to, or alterations of, the Common Areas, or modify, close, remove, eliminate or discontinue use of any common facility, including any improvement or landscaping, except that any such modification, closure, removal, elimination or discontinuance (other than on a temporary basis) of any swimming pool, spa or recreational or community building must be approved by a majority vote of the members at a meeting or by written ballot held or conducted in accordance with these Bylaws.

(l) From time to time adopt, modify, or revoke such rules and regulations governing the details for the operation of the Association, the conduct of Persons and the operation and use of the Property as the Board of Directors may deem necessary or appropriate to ensure the peaceful and orderly use and enjoyment of the Property. Such action may be overruled or modified by vote of not less than 75 percent of the voting rights of each class of members present, in person or by proxy, at any meeting, the notice of which will have stated that such modification or revocation of rules and regulations will be under consideration.

(m) Enforce by legal means the provisions of the Declaration, these Bylaws and any rules and regulations adopted hereunder.

(n) In the name of the Association, maintain a current mailing address of the Association, file annual reports with the Oregon Secretary of State, and maintain and keep current the information required to enable the Association to comply with ORS 94.670(7).

(o) Subject to Section 8.8 of the Declaration, enter into management agreements with professional management firms.

4.8 Meetings.

(a) Meetings of the Board of Directors will be held at such place as may be designated from time to time by the Board or other Persons, calling the meeting.

(b) Annual meetings of the Board of Directors will be held within 30 days following the adjournment of the annual meetings of the members.

(c) Special meetings of the Board of Directors for any purpose or purposes may be called at any time by the President or by any two directors.

Unless other rules of order are adopted by resolution of the Association or the Board of Directors, all meetings of the Board will be conducted according to the latest edition of *Robert's Rules of Order*, published by Robert's Rules Association.

4.9 Open Meetings.

(a) All meetings of the Board of Directors must be open to Owners except that, in the discretion of the Board, the Board may close the meeting to Owners other than Board members and meet in executive session to consult with legal counsel or to consider personnel matters, including salary negotiations and employee discipline, negotiation of contracts with third parties or collection of unpaid assessments. Except in the case of an emergency, the Board will vote in an open meeting on whether to meet in executive session. If the Board votes to meet in executive session, the presiding officer will state the general nature of the action to be considered and; as precisely as possible, when and under what circumstances the deliberations can be disclosed to Owners. The statement, motion or decision to meet in the executive session must be included in the minutes of the meeting, and any contract or action considered in executive session does not become effective unless the Board, following the executive session, reconvenes in open meeting and votes on the contract or action, which is reasonably identified in the open meeting and included in the minutes.

(b) Meetings of the Board of Directors may be conducted by telephonic communication or by other means of communication that allows all members of the Board participating to hear each other simultaneously or otherwise to be able to communicate during the meeting, except that if a majority of the Lots are principal residences of the occupants, then: (i) for other than emergency meetings, notice of each Board's meeting must be posted at a place or places on the property at least three days before the meeting, or notice will be provided by a method otherwise reasonably calculated to inform the Owners of such meeting; and (ii) only emergency meetings of the Board may be conducted by telephonic communication. The meeting and notice requirements of this section may not be circumvented by chance, social meetings, or any other means.

4.10 Notice of Meetings.

(a) Notice of the time and place of meetings will be given to each director orally, or delivered in writing personally, by mail or to the extent permitted by the Oregon Planned Community Act, by electronic mail, facsimile or other form of electronic communication acceptable to the Board of Directors, at least 24 hours before the meeting. Notice is sufficient if received at the required time or if mailed or sent electronically not less than 72 hours before the meeting. If mailed, the notice will be directed to the address shown on the Association's records or to the director's actual address ascertained by the person giving the notice. Such notice need not be given for an adjourned meeting if such time and place is fixed at the meeting adjourned. For a period of 10 years following recording of the Declaration, notices of meetings (including agendas) must also be given to Declarant in the same manner as given to the directors.

(b) Attendance of a director at a meeting constitutes a waiver of notice of such meeting except when a director attends a meeting for the express purpose of objecting to the transaction of any business because the meeting is not lawfully called or convened.

4.11 Quorum and Vote.

(a) A majority of the directors constitutes a quorum for the transaction of business. A minority of the directors, in the absence of a quorum, may adjourn from time to time but may not transact any business.

(b) The action of a majority of the directors present at any meeting at which there is a quorum is the act of the Board of Directors unless a greater number is required by law, the Declaration, the Articles of incorporation or these Bylaws.

(c) A director who is present at a meeting of the Board of Directors at which action is taken on any Association matter is presumed to have assented to the action unless the director votes against the action or abstains from voting on the action because the director claims a conflict of interest. When action is taken on any matter at a meeting of the Board, the vote or abstention of each director present must be recorded in the minutes of the meeting. Directors may not vote by proxy or by secret ballot at meetings of the Board, except that officers may be elected by secret ballot.

4.12 Right Of Declarant To Disapprove Actions. So long as Declarant or any affiliate of Declarant owns any property within Stafford Meadows, directly or indirectly, in whole or in part, Declarant has a right to disapprove any action, policy or program of the Association, the Board of Directors and any committee which, in the sole judgment of the Declarant, would tend to impair the rights of Declarant or builders under the Declaration or these Bylaws, or interfere with development, construction or marketing of any portion of the Property, or diminish the level of services being provided by the Association. This right to disapprove is in addition to, and not in lieu of, any right to approve or disapprove specific actions of the Association, the Board or any committee as may be granted to the Class B Member or Declarant in the Declaration or these Bylaws.

(a) The Declarant must be given written notice of all meetings of the Association, the Board of Directors or any committee thereof and of all proposed actions of the Association, the Board or any committee thereof to be approved at such meetings or by written request in lieu of a meeting. Such notice will be given by certified mail, return receipt requested, or by personal delivery

at the address it has registered with the Secretary of the Association, which notice complies with the requirements for Board meetings set forth in these Bylaws and which notice will, except in the case of the regular meetings held pursuant to the Bylaws, set forth with reasonable particularity the agenda to be followed at such meeting.

(b) The Declarant must be given the opportunity at any such meeting to join in or to have its representatives or agents join in discussion from the floor of any prospective action, policy, or program which would be subject to the right of disapproval set forth herein. The Declarant, its representatives or agents may make its concerns, thoughts, and suggestions known to the Board of Directors and/or the members of the subject committee.

(c) No action, policy or program subject to the right of disapproval set forth herein become effective or be implemented until and unless the requirements of subsections (a) and (b) above have been met and the time period set forth in subsection (d) below has expired.

(d) The Declarant, acting through any officer or director, agent or authorized representative, may exercise its right to disapprove at any time within 10 days following the meeting at which such action was proposed or, in the case of any action taken by written consent in lieu of a meeting, at any time within 10 days following receipt of written notice of the proposed action. This right to disapprove may be used to block proposed actions but does not include a right to require any action or counteraction on behalf of any committee, the Board of Directors, or the Association unless such action or counteraction countermands an action, policy or program that was not properly noticed and implemented. The Declarant will not use its right to disapprove to reduce the level of services which the Association is obligated to provide or to prevent capital repairs or any expenditure required to comply with applicable laws and regulations.

4.13 **Liability.** Neither a member of the Board of Directors nor an officer of the Association or a member of the Architectural Review Committee or any other committee established by the Board will be liable to the Association, any Owner or any third party for any damages, loss or prejudice suffered or claimed on account of any action or failure to act in the performance of his or her duties, so long as the individual acted in good faith, believed that the conduct was in the best interests of the Association, or at least was not opposed to its best interests; and in the case of criminal proceedings, had no reason to believe the conduct was unlawful. In the event any member of the Board or any officer or committee member of the Association is made a party to any proceeding because the individual is or was a director, officer or committee member of the Association, the Association will defend such individual against such claims and indemnify such individual against liability and expenses incurred to the maximum extent permitted by law.

4.14 **Compensation.** No director will receive any compensation from the Association for acting as such.

4.15 **Executive, Covenants and Other Committees.** Subject to law, the provisions of the Declaration and these Bylaws, the Board of Directors, may appoint an Executive Committee, a Covenants Committee to be responsible for covenant enforcement as provided in Section 4.16 and such other standing or temporary committees as may be necessary from time to time consisting of Owners and at least one member of the Board and having such powers as the Board may designate. Such committees hold office at the pleasure of the Board.

4.16 **Enforcement Procedures.** The Association has the power, as provided in the Declaration, to impose sanctions for any violation of the Declaration, these Bylaws or the Rules and Regulations. To the extent specifically required by the Declaration, the Board of Directors must comply with the following procedures prior to the imposition of sanctions:

(a) **Notice.** The Board of Directors or its delegate must serve the alleged violator with written notice describing (i) the nature of the alleged violation, (ii) the proposed sanction to be imposed, (iii) a statement that the alleged violator will have 14 days to present a written request for a hearing before the Board or a Covenants Committee appointed by the Board, if any; and (iv) a statement that the proposed sanction may be imposed as contained in the notice unless a hearing is requested within 14 days of the notice.

(b) **Response.** The alleged violator must respond to the notice of the alleged violation in writing within such 14 day period, regardless of whether the alleged violator is challenging the imposition of the proposed sanction. If the alleged violator cures the alleged violation and notifies the Board of Directors in writing within such 14 day period the Board may, but is not obligated to, waive the sanction. Such waiver does not constitute a waiver of the right to sanction future violations of the same or other provisions by any Person. If a timely request for a hearing is not made, the sanction stated in the notice will be imposed; provided, however, that the Board or Covenants Committee may, but is not obligated to, suspend any proposed sanction if the violation is cured within the 14 day period. Any response or request for a hearing must be delivered to the Association's manager, President or Secretary, or as otherwise specified in the notice of violation.

(c) **Proof of Notice.** Prior to the effectiveness of sanctions imposed pursuant to this section, proof of proper notice must be placed in the minutes of the Board of Directors or Covenants Committee, as applicable. Such proof will be deemed adequate if a copy of the notice, together with a statement of the date and manner of delivery, is entered by the officer, director, or agent who delivered such notice. The notice requirement will be deemed satisfied if the alleged violator or its representative requests and appears at the hearing.

(d) **Hearing.** If a hearing is requested within the allotted 14 day period, the hearing will be held before the Board of Directors or the Covenants Committee, as applicable. The alleged violator will be afforded a reasonable opportunity to be heard. The minutes of the meeting must contain a written statement of the results of the hearing (i.e., the decision) and the sanction, if any, to be imposed.

(e) **Appeal.** Following a hearing before the Covenants Committee, if applicable, the violator must have the right to appeal the decision to the Board of Directors. To exercise this right, the violator must deliver a written notice of appeal to the Association's manager, President or Secretary within 10 days after the hearing date.

(f) **Enforcement Policies.** The Board of Directors, by Resolution, may adopt additional policies and procedures governing enforcement of the Declaration, these Bylaws or the Rules and Regulations.

Article 5

OFFICERS

5.1 **Designation and Qualification.** The officers of the Association are the President, the Secretary, the Treasurer, and such Vice Presidents and subordinate officers as the Board of Directors will from time to time appoint. The President must be a member of the Board, but the other officers need not be directors. Any two offices, except the offices of President and Secretary, may be held by the same person.

5.2 **Election and Vacancies.** The officers of the Association are appointed annually by the Board of Directors at the organization meeting of each new Board to serve for one year and until their respective successors are elected. If any office becomes vacant by reason of death, resignation, removal, disqualification or any other cause, the Board will appoint a successor to fill the unexpired term at any meeting of the Board.

5.3 **Removal and Resignation.**

(a) Any officer may be removed upon the affirmative vote of a majority of the directors whenever, in their judgment, the best interests of the Association will be served thereby. The removal of an officer will be without prejudice to the contract rights, if any, of the officer so removed.

(b) Any officer may resign at any time by giving written notice to the Board of Directors, the President or the Secretary of the Association. Any such resignation takes effect upon receipt of such notice or at any later time specified therein. Unless otherwise specified therein, the acceptance of such resignation is not necessary to make it effective, provided, however, that the Board may reject any postdated resignation by notice in writing to the resigning officer. The effectiveness of such resignation will not prejudice the contract rights, if any, of the Association against the officer so resigning.

5.4 **President.** The President is the chief executive officer of the Association and, subject to the control of the Board of Directors, has powers of general supervision, direction and control of the business and affairs of the Association. He or she presides at all meetings of the members and of the Board. He or she is an ex officio member of all the standing committees, including the executive committee, if any, has the general powers and duties of management usually vested in the office of president of a nonprofit corporation, and has such other powers and duties as may be prescribed by the Board or these Bylaws.

5.5 **Vice Presidents.** The Vice Presidents, if any, performs such duties as the Board of Directors prescribe. In the absence or disability of the President, the President's duties and powers are performed and exercised by the Senior Vice President as designated by the Board.

5.6 **Secretary.**

(a) The Secretary keeps or causes to be kept a book of minutes of all meetings of directors and members showing the time and place of the meeting, whether it was regular or special,

and if special, how authorized, the notice given, the names of those present at directors' meetings, the number of memberships present or represented at members' meetings and the proceedings thereof.

(b) The Secretary gives or causes to be given such notice of the meetings of the members and of the Board of Directors as is required by these Bylaws or by law. The Secretary keeps the seal of the Association, if any, and affixes it to all documents requiring a seal, and has such other powers and perform such other duties as may be prescribed by the Board or these Bylaws.

(c) If there are no Vice Presidents, then in the absence or disability of the President, the President's duties and powers are performed and exercised by the Secretary.

5.7 **Treasurer.** The Treasurer keeps and maintains, or causes to be kept and maintained, adequate and correct accounts of the properties and business transactions of the Association, including accounts of its assets, liabilities, receipts and disbursements. The books of accounts must at all reasonable times be open to inspection by any director. The Treasurer deposits or causes to be deposited all moneys and other valuables in the name and to the credit of the Association with such depositories as may be designated by the Board of Directors. The Treasurer disburses or causes to be disbursed the funds of the Association as may be ordered by the Board, renders to the President and directors, whenever they request it, an account of all of the Treasurer's transactions as Treasurer and of the financial condition of the Association, and has such other powers and perform such other duties as may be prescribed by the Board or these Bylaws.

5.8 **Compensation of Officers.** No officer who is a member of the Board of Directors will receive any compensation from the Association for acting as an officer, unless such compensation is authorized by a resolution duly adopted by the members. The Board may fix any compensation to be paid to other officers.

Article 6

ASSESSMENTS, RECORDS AND REPORTS

6.1 **Assessments.** As provided in the Declaration, the Association, through its Board of Directors, will do the following:

(a) Assess and collect from every Owner Assessments in the manner described in the Declaration.

(b) Keep all funds received by the Association as Assessments, other than reserves described in the Declaration, in the Operations Fund and keep all reserves collected pursuant to the Declaration in the Reserve Fund and use such funds only for the purposes described in the Declaration. All assessments will be deposited and maintained in the name of the Association in one or more separate federally insured accounts, including certificates of deposit, at a financial institution as defined in ORS 706.008, other than an extranational institution. Such funds may be used to purchase obligations of the United States government. All expenses of the Association are paid from the Association's bank account.

(c) From time to time, and at least annually, prepare a budget for the Association, estimating the common expenses expected to be incurred with adequate allowance for reserves based

upon the reserve study required by the Declaration and determine whether the General Assessment should be increased or decreased. Within 30 days after adopting a proposed annual budget, the Board of Directors will provide a summary of the budget to all Owners. If the Board fails to adopt a budget, the last adopted annual budget continues in effect.

(d) Fix the amount of the General Assessment against each Lot at least 30 days in advance of each General Assessment period. Written notice of any Assessment will be sent to every Owner subject thereto and to any first Mortgagee requesting such notice. The due dates will be established by the Board of Directors, which may fix a regular flat Assessment payable on a monthly, quarterly, semiannual or annual basis. The Board will cause to be prepared a roster of the Lots showing Assessments applicable to each Lot. The roster will be kept in the Association office and subject to inspection by any Owner or Mortgagee during regular business hours. Within 10 business days after receiving a written request, and for a reasonable charge, the Association will furnish to any Owner or Mortgagee a recordable certificate setting forth the unpaid Assessments against such Owner's Lot. Such certificate is binding upon the Association, the Board, and every Owner as to the amounts of unpaid Assessments.

(e) When Additional Properties are annexed, the Board of Directors will assess any Lots included therein in accordance with Section 10.5 of the Declaration.

(f) Enforce the Assessments in the manner provided in the Declaration.

(g) Keep records of the receipts and expenditures affecting the Operations Fund and Reserve Fund and make the same available for examination by members and their Mortgagees at convenient hours, maintain an Assessment roll showing the amount of each Assessment against each Owner, the amounts paid upon the account and the balance due on the Assessments, give each member written notice of each Assessment at least 30 days before the time when such Assessments will become due and payable; and for a reasonable charge, promptly provide any Owner or Mortgagee who makes a request in writing with a written certificate of such Owner's unpaid Assessments.

6.2 **Records.** The Association will keep within the State of Oregon correct and complete financial records sufficiently detailed for proper accounting purposes, keep minutes of the proceedings of its members, Board of Directors and committees having any of the authority of the Board, and retain all documents, information and records turned over to the Association by Declarant. All documents, information and records delivered to the Association by Declarant pursuant to ORS 94.616 will be kept within the State of Oregon.

6.3 **Statement of Assessments Due.** The Association will provide, within 10 business days after receipt of a written request from an Owner, a written statement that provides: (a) the amount of assessments due from the Owner and unpaid at the time the request was received, including regular and special assessments, fines and other charges, accrued interest, and late-payment charges; (b) the percentage rate at which interest accrues on assessments that are not paid when due; and (c) the percentage rate used to calculate the charges for late payment or the amount of a fixed-rate charge for late payment. The Association is not required to comply with this section if the Association has commenced litigation by filing a complaint against the Owner and the litigation is pending when the statement would otherwise be due.

6.4 **Inspection of Books and Records.** Except as otherwise provided in ORS 94.670(5), during normal business hours or under other reasonable circumstances, the Association must make reasonably available for examination and, upon written request, available for duplication, by Owners, lenders, and holders of any Mortgage of a Lot that make the request in good faith for a proper purpose, current copies of the Declaration, Articles, Bylaws, Rules and Regulations, amendments or supplements to such documents and the books, records, financial statements and current operating budget of the Association. The Association will maintain a copy, suitable for purposes of duplication, of each of the following: (a) the Declaration, these Bylaws, the Rules and Regulations and any amendments or supplements to them, (b) the most recent financial statement of the Association, and (c) the current operating budget of the Association. The Association, within 10 business days after receipt of a written request by an Owner, will furnish copies of such documents to the requesting Owner. Upon written request, the Association will make such documents, information and records available to such Persons for duplication during reasonable hours. The Board of Directors, by resolution, may adopt reasonable rules governing the frequency, time, location, notice and manner of examination and duplication of Association records and the imposition of a reasonable fee for furnishing copies of such documents, information or records. The fee may include reasonable personnel costs for furnishing the documents, information or records.

6.5 **Payment of Vouchers.** The Treasurer or managing agent will pay all vouchers for all budgeted items and for any nonbudgeted items, up to \$1,000 signed by the President, managing agent, manager or other person authorized by the Board of Directors. Any voucher for nonbudgeted items in excess of \$1,000 requires the authorization of the President or a resolution of the Board.

6.6 **Execution of Documents.** The Board of Directors may, except as otherwise provided in the Declaration, Articles of Incorporation; or these Bylaws, authorize any officer or agent to enter into any contract or execute any instrument in the name of and on behalf of the Association. Such authority may be general or confined to specific instances. Unless so authorized by the Board, no officer, agent, or employee has any power or authority to bind the Association by any contract or engagement, to pledge its credit, or to render it liable for any purpose or for any amount.

6.7 **Reports and Audits.** An annual financial statement consisting of a balance sheet and an income and expense statement for the preceding year will be rendered by the Board of Directors to all Owners and to all Mortgagees who have requested the same within 90 days after the end of each fiscal year. Commencing with the fiscal year following the Turnover Meeting, if the General Assessments exceed \$75,000 for the year, then the Board will cause such financial statements to be reviewed within 300 days after the end of the fiscal year by an independent certified public accountant licensed in Oregon in accordance with the Statements on Standards for Accounting and Review Services issued by the American Institute of Certified Public Accountants, or if the General Assessments are \$75,000 or less, will cause such review within 300 days after receipt of a petition requesting such review signed by at least a majority of owners. The Board need not cause such a review to be performed if so directed by an affirmative vote of at least 60 percent of the Owners, not including votes of Declarant with respect to Lots owned by Declarant. From time to time, the Board, at the expense of the Association, may obtain an audit of the books and records pertaining to the Association and furnish copies thereof to the members. At any time an Owner or holder of a Mortgage may, at their own expense, cause an audit or inspection to be made of the books and records of the Association.

Article 7

INSURANCE

7.1 **Types of Insurance.** For the benefit of the Association and the Owners, the Board of Directors will obtain and maintain at all times, and pay for out of the Operations Fund, the following insurance:

(a) **Property Damage Insurance.**

(1) The Association will maintain a policy or policies of insurance covering loss or damage from fire, with standard extended coverage and "all risk" endorsements, and such other coverages as the Association may deem desirable.

(2) The amount of the coverage will be for not less than 100 percent of the current replacement cost of the improvements on the Common Areas (exclusive of land, foundation, excavation and other items normally excluded from coverage), subject to a reasonable deductible not to exceed \$10,000.

(3) The policy or policies will include all fixtures and building service equipment to the extent that they are part of the Common Areas and all personal property and supplies belonging to the Association.

(b) **Liability Insurance.**

(1) The Association will maintain comprehensive general liability insurance coverage insuring the Declarant, the Association, the Board of Directors, and the managing agent, against liability to the public or to Owners and their invitees or tenants, incident to the operation, maintenance, ownership or use of the Common Areas, including legal liability arising out of lawsuits related to employment contracts of the Association. There may be excluded from such policy or policies coverage of an Owner (other than as a member of the Association or Board) for liability arising out of acts or omissions of such Owner and liability incident to the ownership and/or use of the part of the Property as to which such Owner has the exclusive use or occupancy.

(2) Limits of liability under such insurance will not be less than \$1,000,000 on a combined single-limit basis.

(3) Such policy or policies will be issued on a comprehensive liability basis and provide a cross-liability endorsement wherein the rights of named insureds under the policy or policies are not prejudiced as respects his, her or their action against another named insured.

(c) **Workers' Compensation Insurance.** The Association will maintain workers' compensation insurance to the extent necessary to comply with any applicable laws.

(d) **Fidelity Insurance.**

(1) The Board of Directors will cause the Association to maintain blanket fidelity insurance for all officers, directors, trustees and employees of the Association and all other

Persons handling or responsible for funds of, or administered by, the Association. In the event that the Association has retained a management agent, the Board may require such agent to maintain fidelity insurance for its officers, employees and agents handling or responsible for funds of, or administered on behalf of, the Association. The cost of such insurance, if any, is borne by the Association.

(2) The total amount of fidelity insurance coverage required will be based upon the best business judgment of the Board of Directors.

(3) Such fidelity insurance will name the Association as obligee and contain waivers by the insurers of all defenses based upon the exclusion of Persons serving without compensation from the definition of "employees" or similar terms or expressions. The insurance will provide that it may not be canceled or substantially modified (including cancellation for nonpayment of premium) without at least 10 days' prior written notice to the Association.

(e) **Director's and officers' liability insurance.** The Association will maintain a policy of directors' and officers' liability insurance with coverage in the amount of not less than \$1,000,000 subject to a reasonable deductible, which deductible is the responsibility of the Association. Such insurance will cover both interim and regular directors and will include coverage for claims brought by the Association, Owners and/or third parties, including, without limitation, claims arising out of construction defects or failure to maintain adequate reserves. Directors and officers will be accepting such positions in reliance upon such insurance protection being maintained by the Association. Therefore, in the event the Association fails to carry such insurance or amends these Bylaws to delete or reduce these insurance requirements, the Association and Owners will be deemed to have released such claims and deemed to have covenanted not to sue or prosecute any claims against its current or former directors or officers that would have been insured under such a policy.

7.2 **Insurance by Lot Owners.** Each Owner are responsible for obtaining, at his or her own expense, homeowner's insurance covering the improvements on the Owner's Lot and liability resulting from use or ownership of the Lot, unless the Association agrees otherwise. The insurance coverage maintained by the Association may not be brought into contribution with the insurance obtained under this section by the Owners.

7.3 **Planned Community Act Requirements.** The insurance maintained by the Association must comply with the requirements of the Oregon Planned Community Act, ORS 94.550 to 94.780.

Article 8

GENERAL PROVISIONS

8.1 **Seal.** The Board of Directors may, by resolution, adopt a corporate seal.

8.2 **Notice.** All notices to the Association or to the Board of Directors will be sent care of the managing agent, or if there is no managing agent, to the principal office of the Association or to such other address as the Board of Directors may hereafter designate from time to time. All notices to members will be sent to the member's unit or to such other address as may have been designated by the member from time to time in writing to the Board of Directors.

8.3 **Waiver of Notice.** Whenever any notice to any member or director is required by law, the Declaration, the Articles of Incorporation, or these Bylaws, a waiver of notice in writing signed at any time by the Person entitled to notice is equivalent to the giving of the notice.

8.4 **Action Without Meeting.** Any action that the law, the Declaration, the Articles of Incorporation or the Bylaws require or permit the members or directors to take at any meeting may be taken without a meeting or ballot meeting if a consent in writing setting forth the action so taken is signed by all of the members or directors entitled to vote on the matter. The consent, which will have the same effect as a unanimous vote of the members or directors, will be filed in the records of minutes of the Association.

8.5 **Conflicts.** These Bylaws are intended to comply with the Oregon Planned Community Act, the Oregon Nonprofit Corporation Law, the Declaration and the Articles of Incorporation. In case of any irreconcilable conflict, such statutes and documents control over these Bylaws.

Article 9

AMENDMENTS TO BYLAWS

9.1 **How Proposed.** Amendments to these Bylaws must be proposed by either a majority of the Board of Directors or by members holding at least 30 percent of the voting rights entitled to be cast for such amendment. The proposed amendment must be reduced to writing and must be included in the notice of any meeting at which action is to be taken thereon or be attached to any request for consent to the amendment.

9.2 **Adoption.**

(a) A resolution adopting a proposed amendment may be proposed by either the Board of Directors or by the members and may be approved by the membership at a meeting called for such purpose, or by written consent of the members. Members not present at the meeting considering such amendment may express their approval in writing or by proxy. Any resolution must be approved by members holding a majority of the voting rights, together with the written consent of the Class B Member, if any. Amendment or repeal of any provision of these Bylaws that is also contained in the Declaration must be approved by the same voting requirement for amendment of such provision of the Declaration.

(b) Notwithstanding the provisions of the preceding paragraph, until the Turnover Meeting has occurred, Declarant has the right to amend these Bylaws in order to comply with the requirements of the Federal Housing Administration, the United States Department of Veterans Affairs, the Farmers Home Administration of the United States, the Federal National Mortgage Association, the Government National Mortgage Association, the Federal Home Mortgage Loan Corporation, any department, bureau, board, commission or agency of the United States or the State of Oregon, or any corporation wholly owned, directly or indirectly, by the United States or the State of Oregon that insures, guarantees or provides financing for a planned community or lots in a planned community. After the Turnover Meeting, any such amendment must be approved as provided in Section 9.2(a).

9.3 **Execution and Recording.** An amendment will not be effective until certified by the President and Secretary of the Association as being adopted in accordance with these Bylaws and ORS 94.625 and recorded in the Deed Records of Clackamas County, Oregon.

23

Appendix H

Example Building Elevations





WEST HILLS
HOMES NORTHWEST

2746 BAYBERRY
PRAIRIE (2-CAR)

M. FLR.	=	1,685 S.F.
U. FLR.	=	1,061 S.F.
TOTAL	=	2,746 S.F.
GARAGE	=	499 S.F.



EVERETT

CUSTOM HOMES

3-BEDROOMS
2.5-BATHS
MEDIA
2-CAR GARAGE

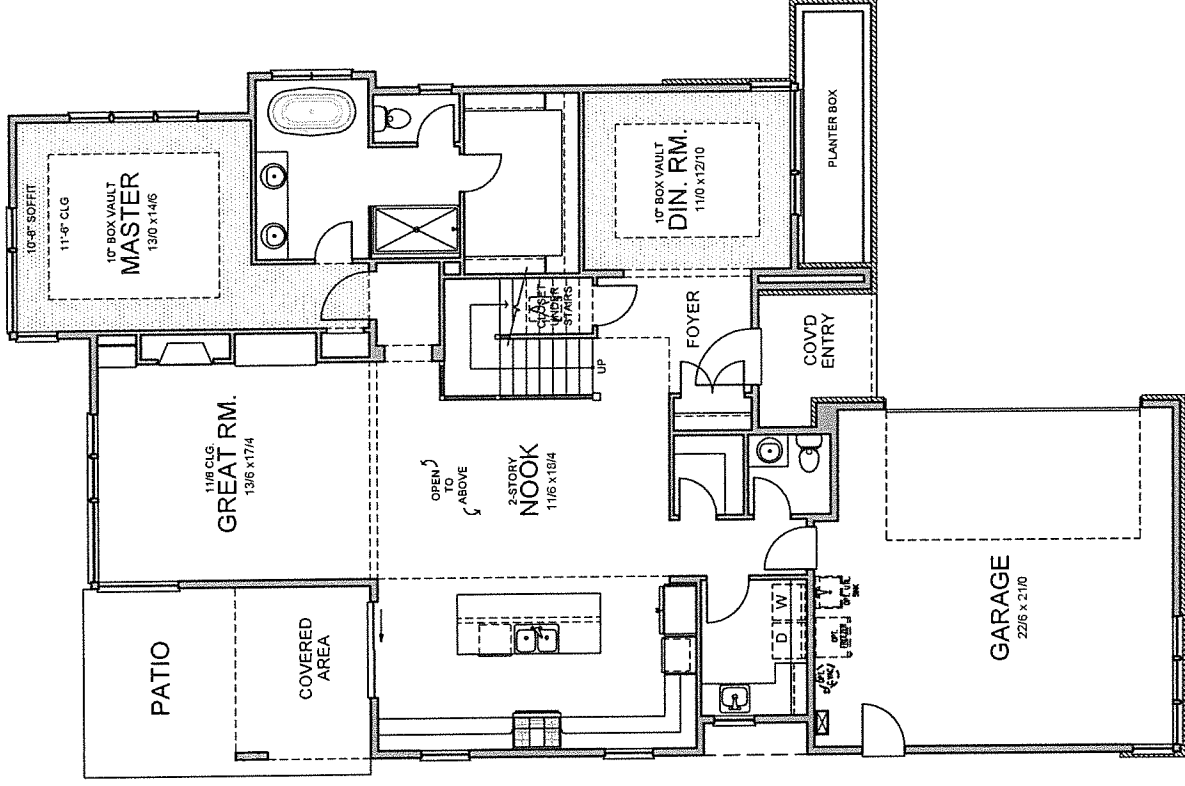
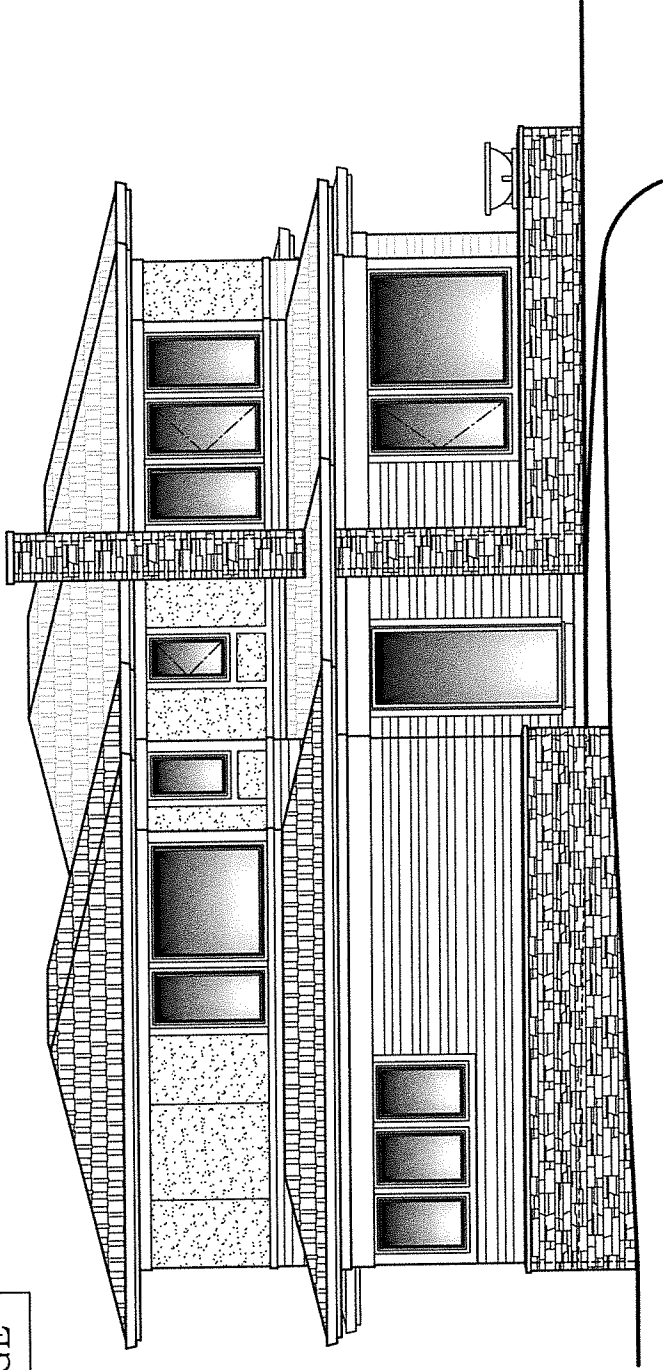

MAIN LEVEL FLOOR PLAN (9' & 11/6 CLG.)

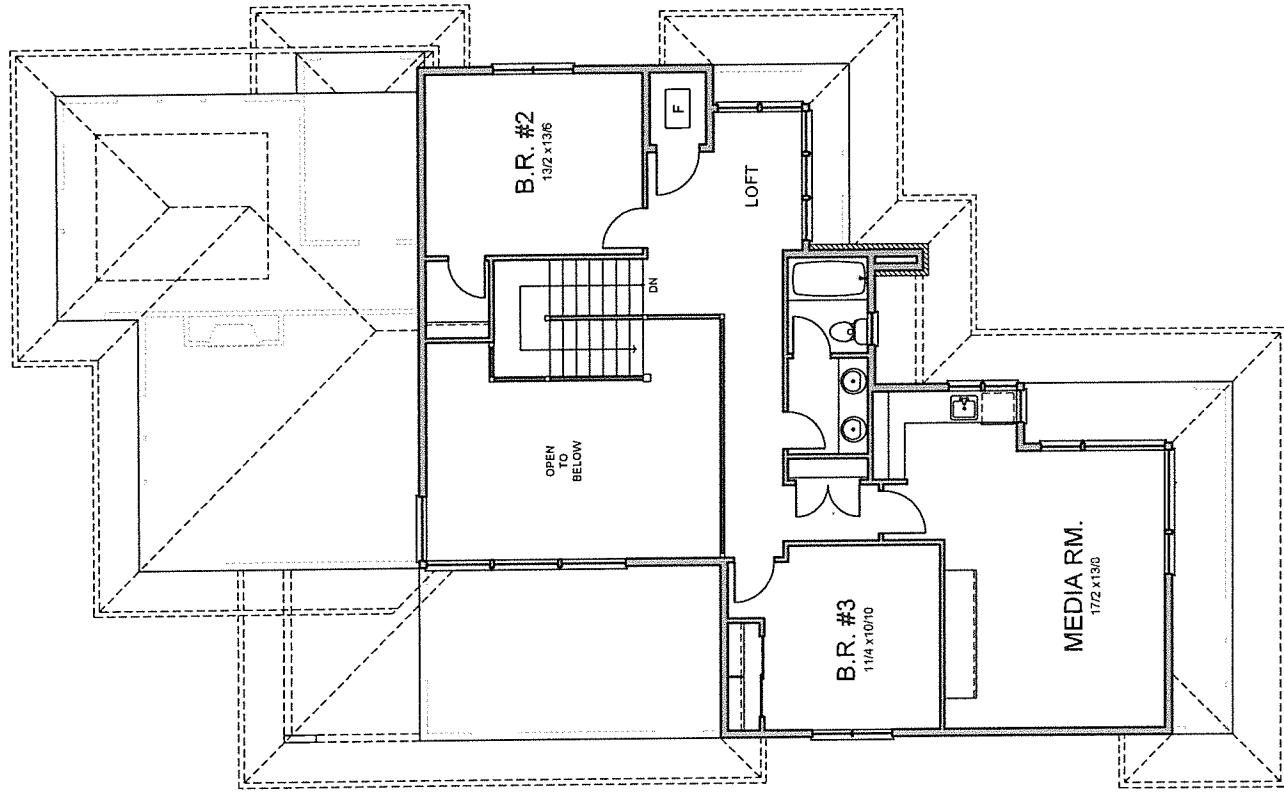

UPPER LEVEL FLOOR PLAN (8' CLG.)



WEST HILLS
HOMES NORTHWEST

4-BEDROOMS
2-BATHS
3-CAR GARAGE

2480 ESLINGER
PRAIRIE

M. FLR. = 2,480 S.F.
TOTAL = 2,480 S.F.
GARAGE = 826 S.F.



EVERETT

CUSTOM HOMES

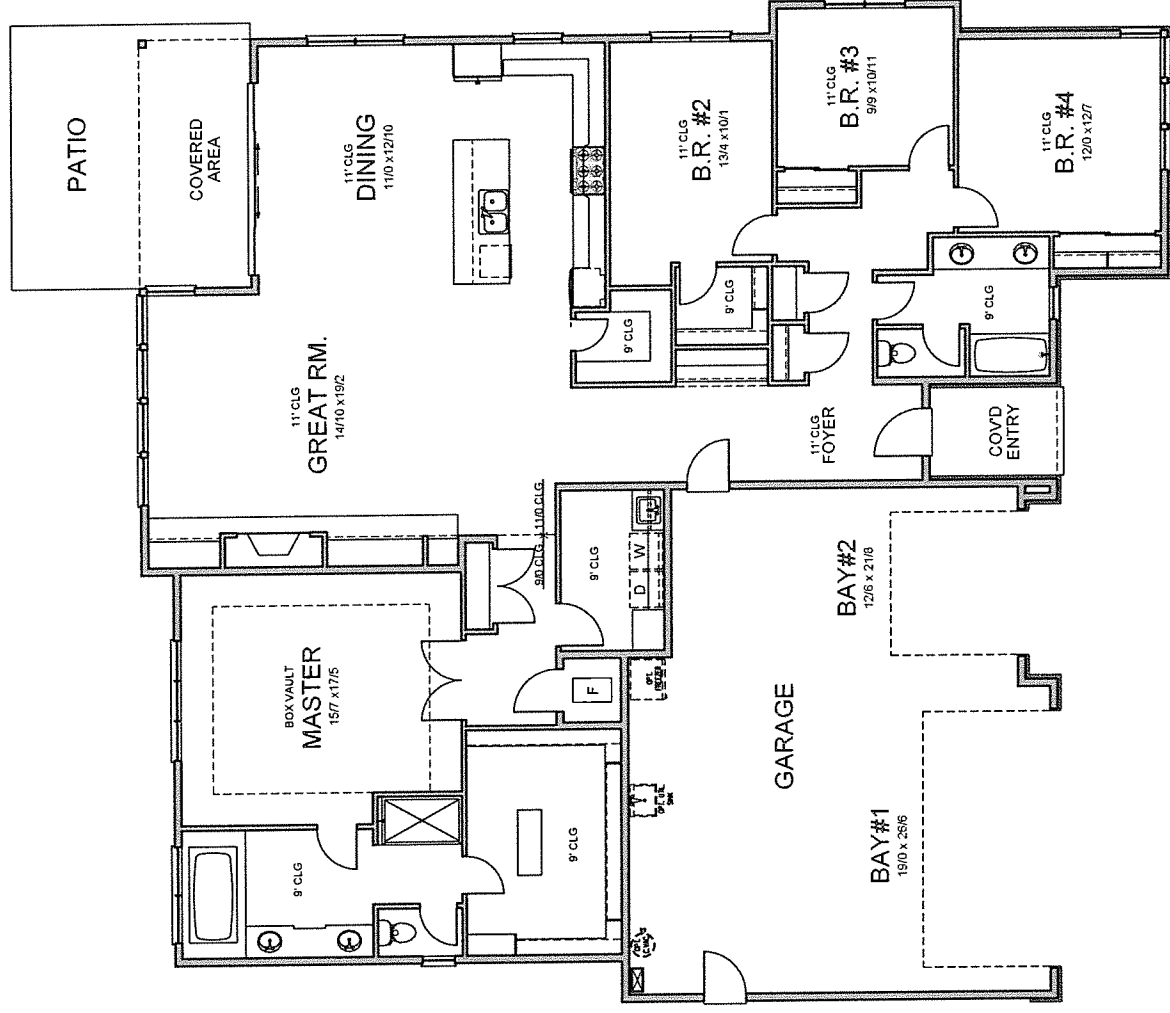
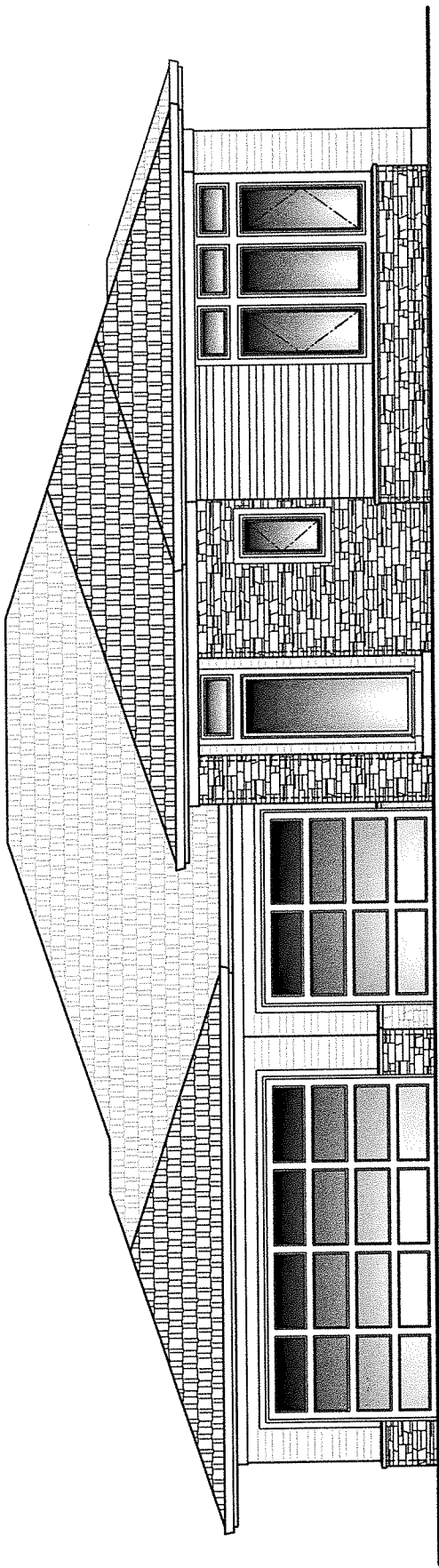

MAIN LEVEL FLOOR PLAN (9' & 11' CLG'S.)



WEST HILLS
HOMES NORTHWEST



EVERETT

CUSTOM HOMES

3300 NW VEON AVE STE. 100
PORTLAND, OREGON 97210
PHONE (503) 726-1060

These building plans are protected by United States federal and state copyright law. The copyright in these plans is owned by West Hills Homes Northwest, a division of West Hills Homes Northwest Company. No part of these plans may be reproduced, stored in a retrieval system, or transmitted in any form or by any means, electronic, mechanical, photocopying, recording, or by any information storage and retrieval system, without the prior written permission of West Hills Homes Northwest Company. Except in accordance with the copyright law, no part of the building plans may be used for the construction of any residence and every not be used hereafter. Any infringement of these plans may result in legal action and penalties as provided in a contract addendum.

9/18/17, PRELIM. LAYOUT DOR
9/27/17, PRELIM. ENG. CHK. DOR
10/20/17, FIN. ENG. CHK. DOR
10/20/17, PUBLISH PLAN DOR

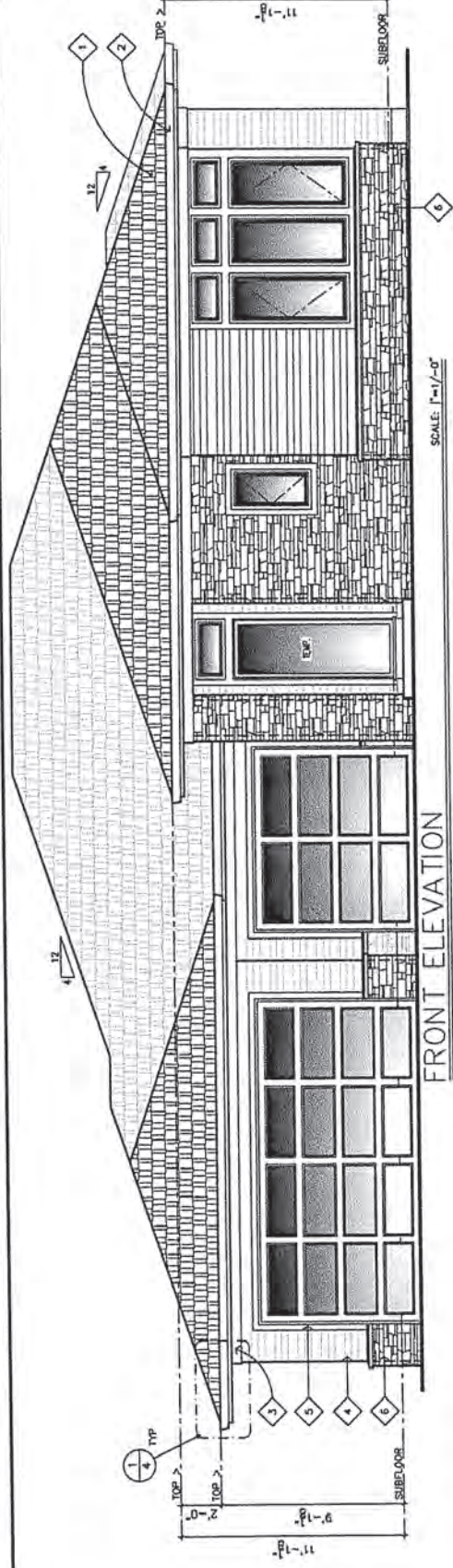

FRONT ELEVATION

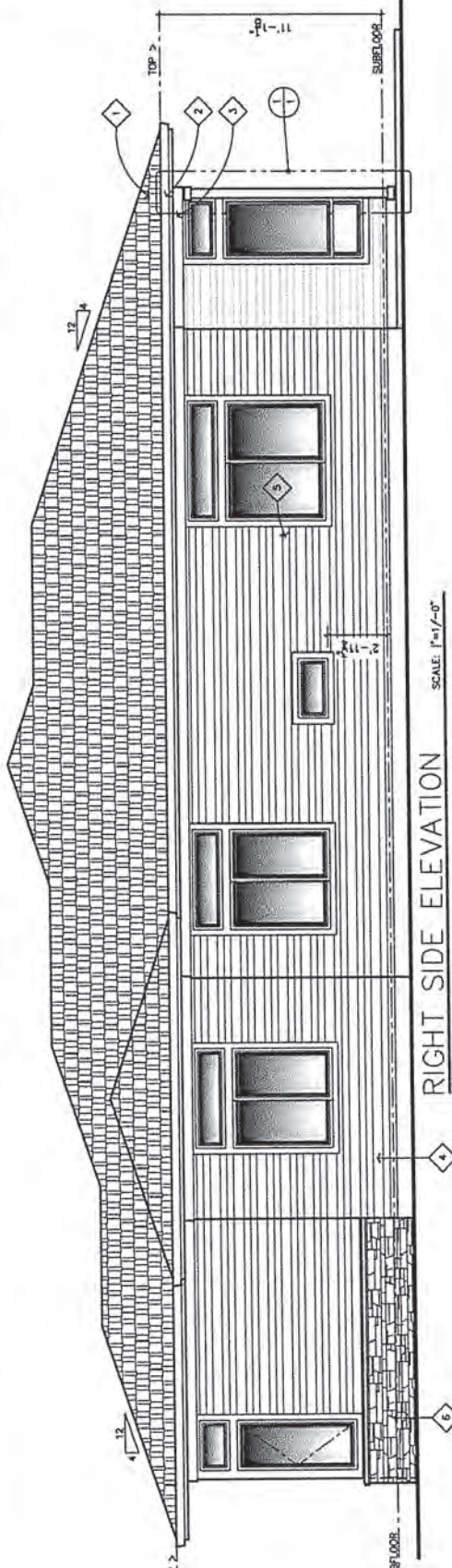

RIGHT SIDE ELEVATION

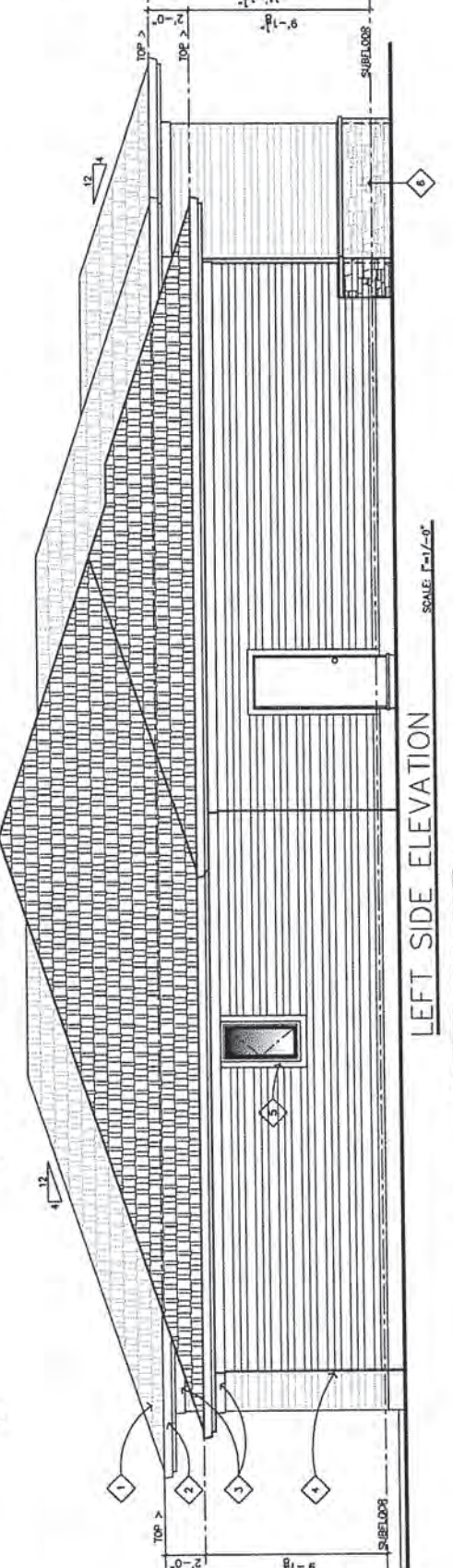

LEFT SIDE ELEVATION

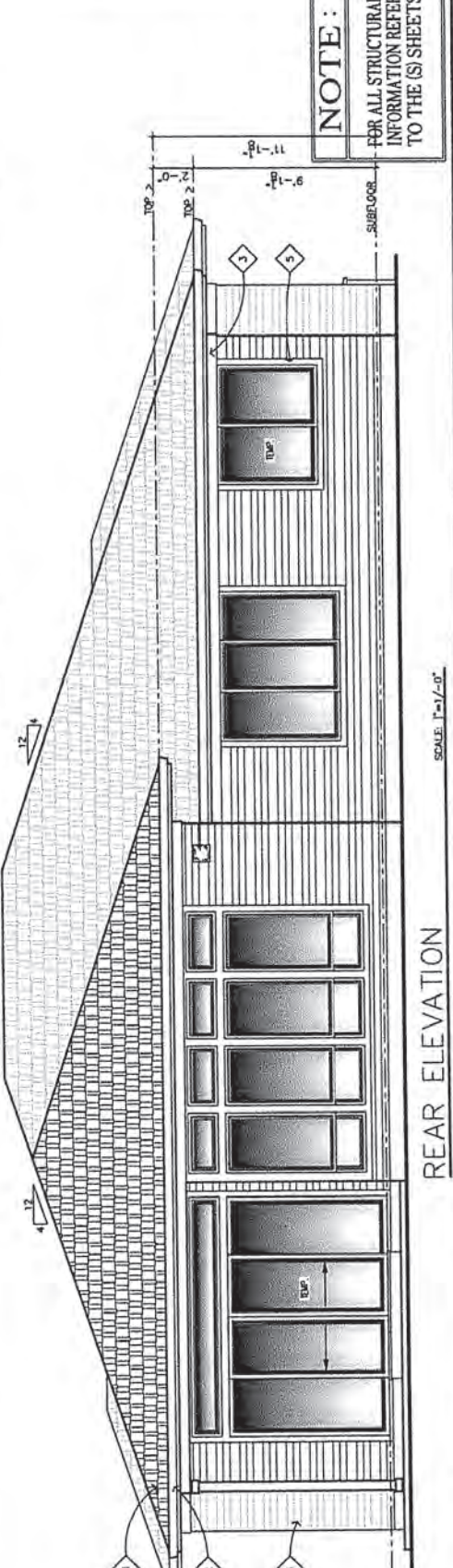

REAR ELEVATION

PLAN 2480
ESLINGER
PRAIRIE
GARAGE LEFT

WASH LEVEL: 2,460.50 FT
GRAND TOTAL: 2,460.50 FT
GARAGE: 806.50 FT
SHEET 1

NOTE:

FOR ALL STRUCTURAL INFORMATION REFER TO THE (S) SHEETS

SCALE: 1/4"=1'-0"

© 2017 EVERETT CUSTOM HOMES



WEST HILLS
HOMES NORTHWEST

3557 DUNTHORPE	
FRENCH	
M. FLR.	= 1,605 S.F.
U. FLR.	= 1,917 S.F.
BONUS	= 451 S.F.
TOTAL	= 3,973 S.F.
GARAGE	= 636 S.F.



EVERETT
CUSTOM HOMES

5-BEDROOMS
3-BATHS
MEDIA, BONUS
TANDEM 3-CAR GARAGE

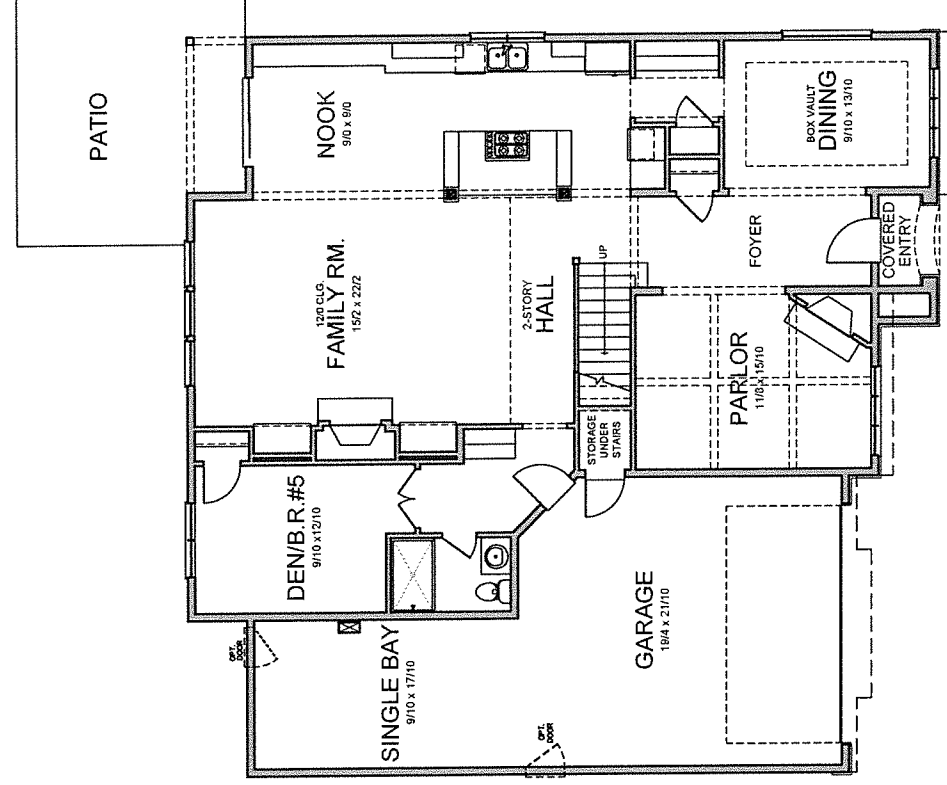
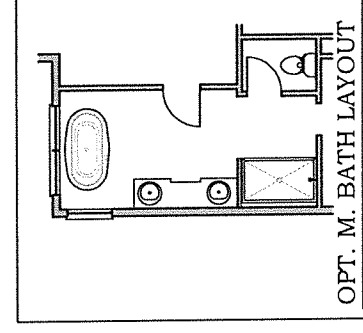
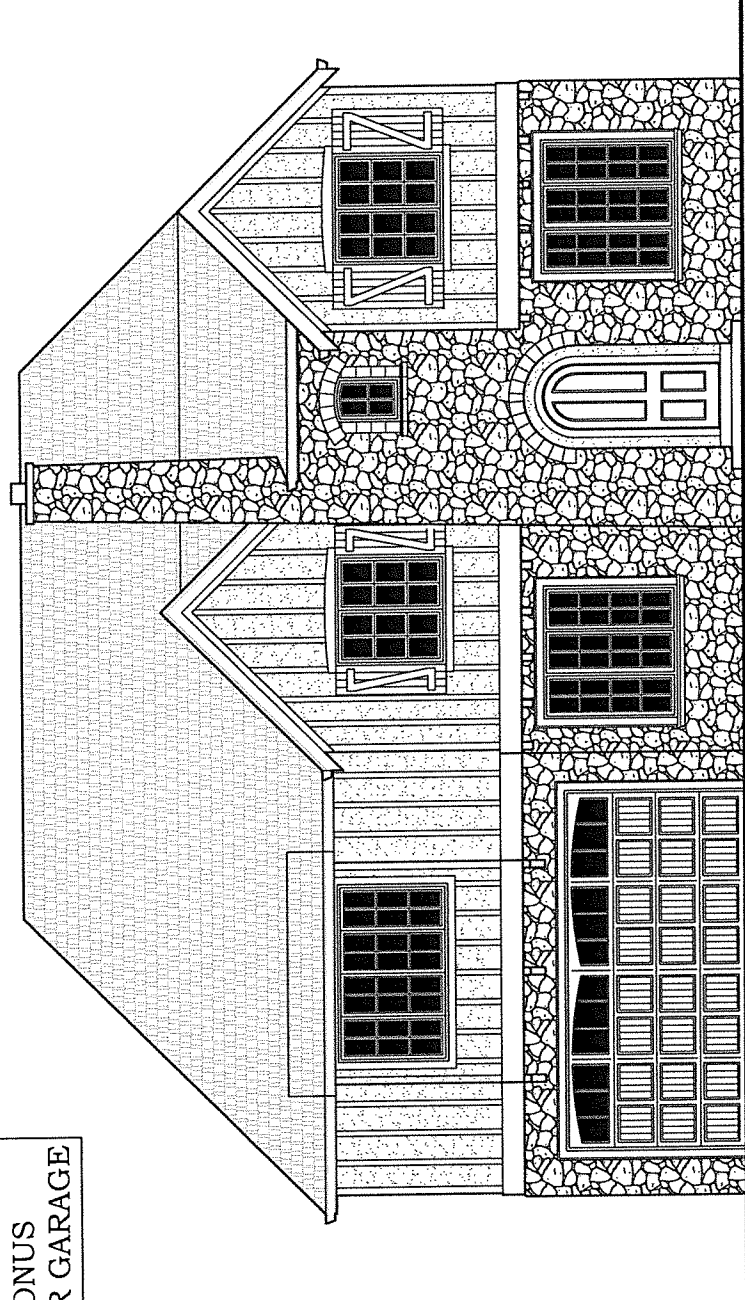

MAIN LEVEL FLOOR PLAN (9' CLG.)

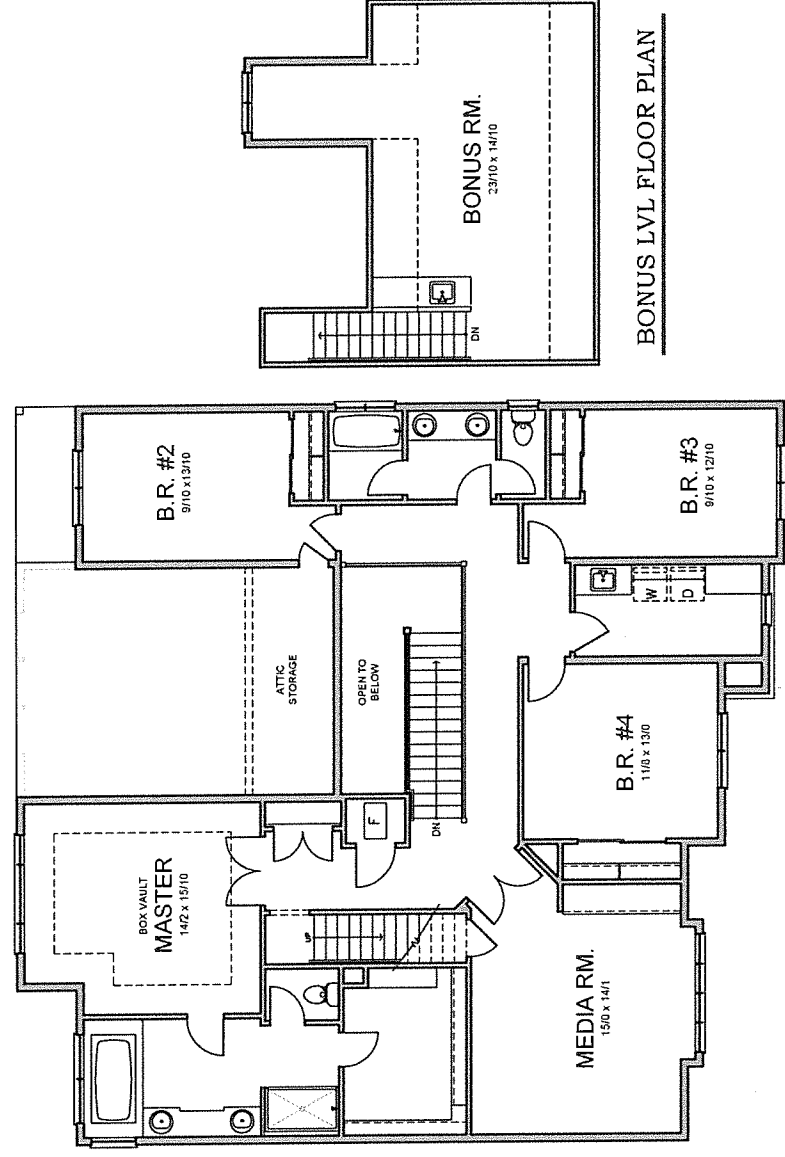

UPPER LEVEL FLOOR PLAN (8' CLG.)



WEST HILLS
HOMES NORTHWEST



EVERETT
CUSTOM HOMES

3330 NW YEON AVE STE 100
PORTLAND, OREGON 97210
PHONE 503 726-7060

Each building plan is protected by United States Patent and Trademark Office copyright law. No copyright in these building plans is owned by West Hills Development Company. Permission to the United States Patent and Trademark Office to register these building plans as prior art is hereby granted. The copyright notice hereby granting a copy of EVERETT CUSTOM HOMES Company. Except in accordance with the terms of the license agreement, no other use of the copyright of the building plan may be made without the prior written consent of EVERETT CUSTOM HOMES Company and may only be used for the construction of one residence. Any other use of the copyright of the building plan may be considered an infringement of the copyright of the building plan and may result in legal action or a criminal offense.

10/27/16 ED-WALK-THROUGH
1/27/17 ERI-BRUTE FR-26 (16-13) DOR
1/27/17 ERI-BRUTE FR-26 (16-13) DOR
3/7/17 ERI-TOLER TRANSFER DOR

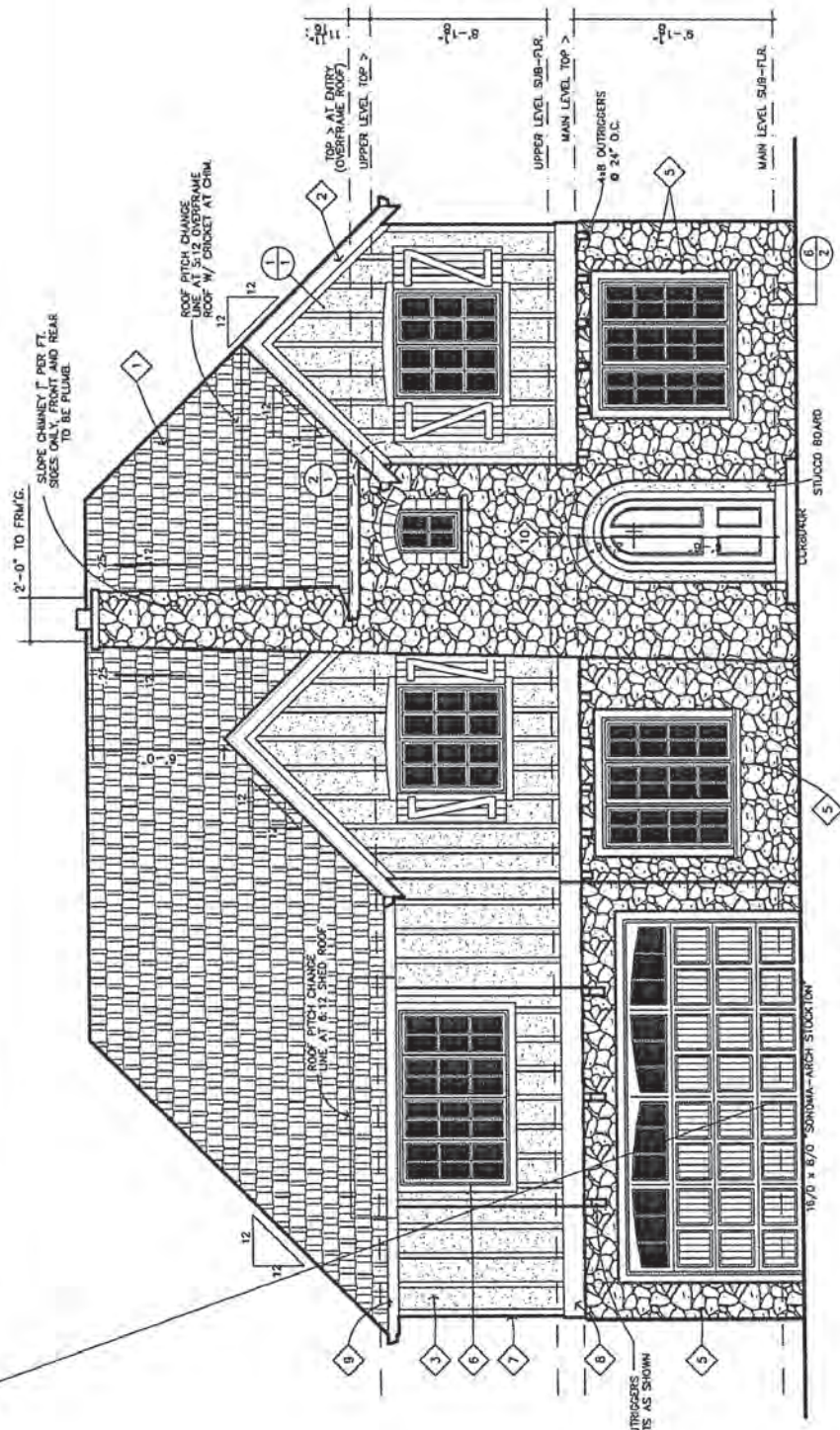

FRONT ELEVATION

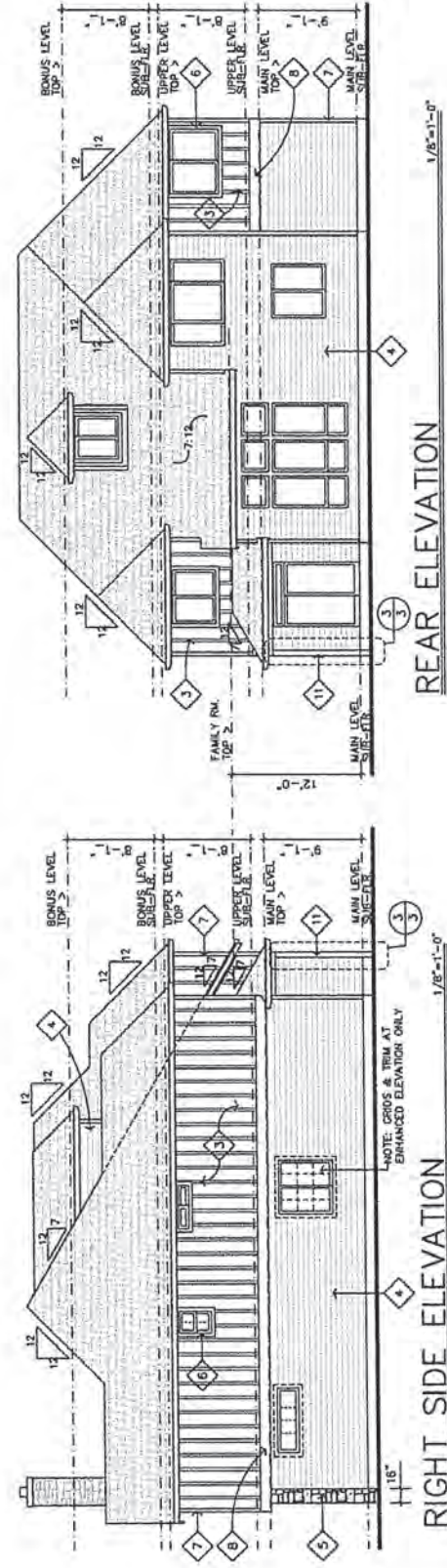

REAR ELEVATION

- ELEVATION KEYNOTES**
1. ROOFING (TYPICAL): 30 YEAR HEAVY WEIGHT FIBERGLASS COMPOSITION ROOFING.
 2. VOICE BOARD TYPICAL: 1/2" TRIM ON 2x4 VOICE BOARD. PROVIDE 1/2" TRIM ON LAP SINGING (LAP SINGING) ON 1x6 PANEL SINGING. TRIM BOARD FLAT ON WALL AND BUTT TO UNDERSIDE OF ROOF SHEATHING FOLLOWING.
 3. SINGING (TYPICAL): HARDIE STUCCO BRO. SINGING W/ 1 x 3 BATTENS SPACED AT 16" O.C.
 4. SINGING (TYPICAL WHERE SHOWN): HARDIE-BOARD LAP SINGING.
 5. CULTURED STONE (TYPICAL): INSTALL STONE, SILL & TRIM STONE WHERE SHOWN ON ELEV. INSTALL PER MANUFACTURER'S RECOMMENDATIONS. SEE VENER DETAILS 3/1, 4/1, 5/2 FOR INFO.
 6. WINDOW TRIM: 5/4 x 4 AROUND ALL WINDOWS AND DOORS AT FRONT AND ALL WINDOWS AT PANEL AND BATTEN SINGING. NO WINDOW TRIM AT LAP SINGING UNLESS AT ENHANCED ELEVATIONS. FLASH ABOVE ALL HORIZONTAL TRIM.
 7. 5/4 x 4 CORNER TRIM AT LAP SINGING. 1 x 4 CORNER TRIM AT PANEL SINGING.
 8. HORIZONTAL TRIM: 5/4 x 12 W/ 26 GA. 1" FLASHING OVER TOP AND INTEGRATED W/ WEIR.
 9. GUTTERS (TYP-JUN 03): 6" FASCIA STYLE 26 GA. STEEL GUTTER WITH 2"x3" STEEL DOWN-PIPE. ALL GUTTERS AND DOWNPIPES TO BE INSTALLED AND ALL EQUIV. CONNECT ALL DOWNSPOUTS TO RAIN DRAINS WHERE PROVIDED.
 10. 6x8 TRIMSTONE PER MFR.
 11. P.I. 6x6 POST -BATED FOR BURIAL. SEE DETAIL 5/3

RIGHT SIDE ELEVATION

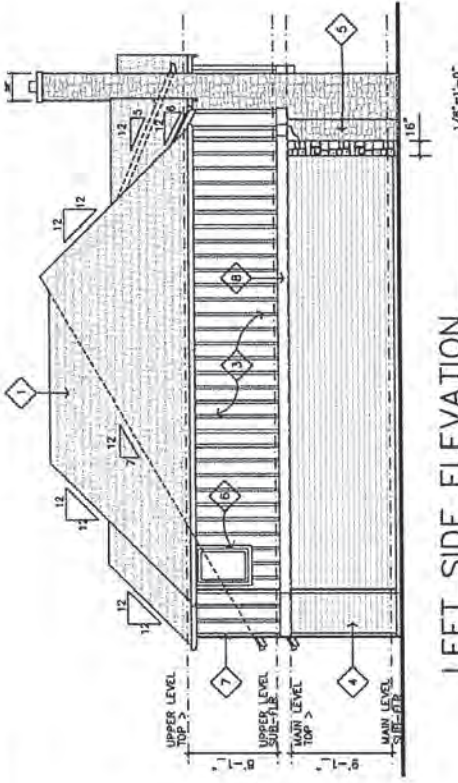

LEFT SIDE ELEVATION

NOTE:
FOR ALL STRUCTURAL INFORMATION REFER TO THE (S) SHEETS

PLAN 3557
DUNTHORPE
FRENCH LEFT
GARAGE LEFT

MAIN LEVEL: 1605 SQ FT
UPPER LEVEL: 1975 SQ FT
TOTAL: 3580 SQ FT
GARAGE: 650 SQ FT
GRAND TOTAL: 3975 SQ FT

JOB NO.



WEST HILLS
HOMES NORTHWEST

2957 WESTLAKE ENGLISH (PH-23)	
M. FLR.	= 1,877 S.F.
U. FLR.	= 1,080 S.F.
TOTAL	= 2,957 S.F.
GARAGE	= 615 S.F.



EVERETT
CUSTOM HOMES

4-BEDROOMS
3-BATHS
MEDIA
3-CAR GARAGE

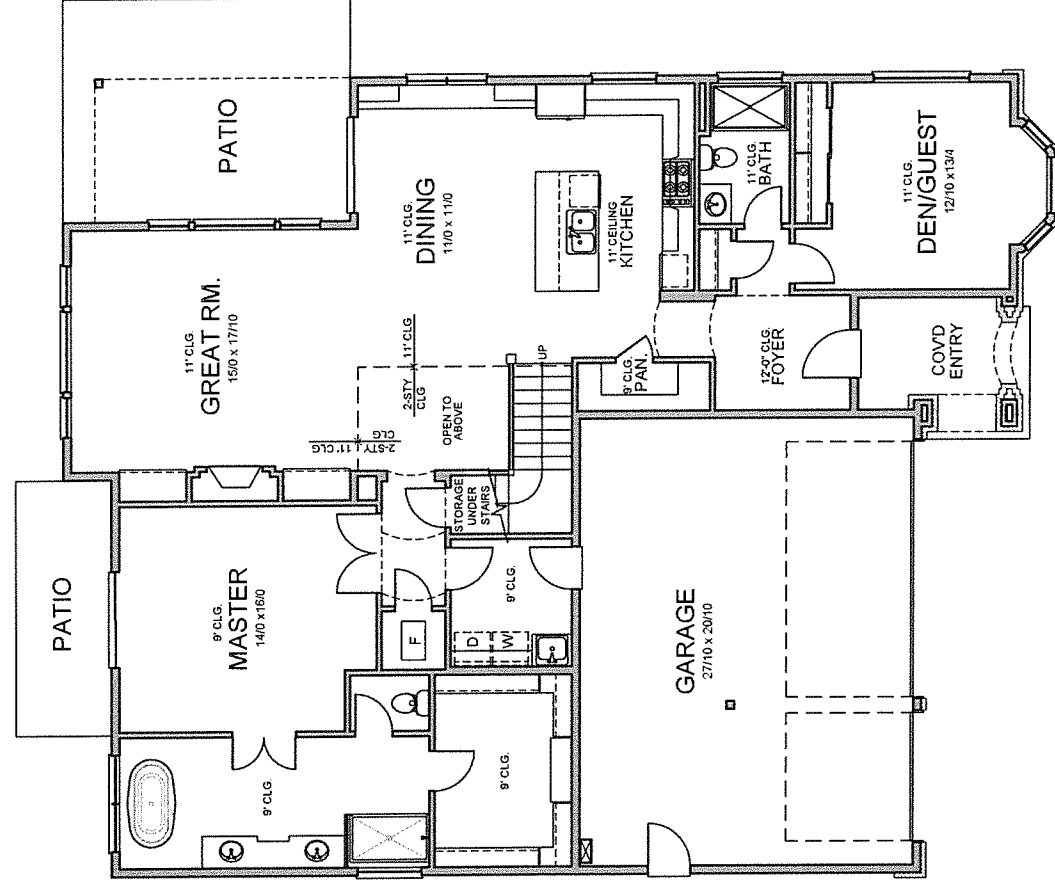
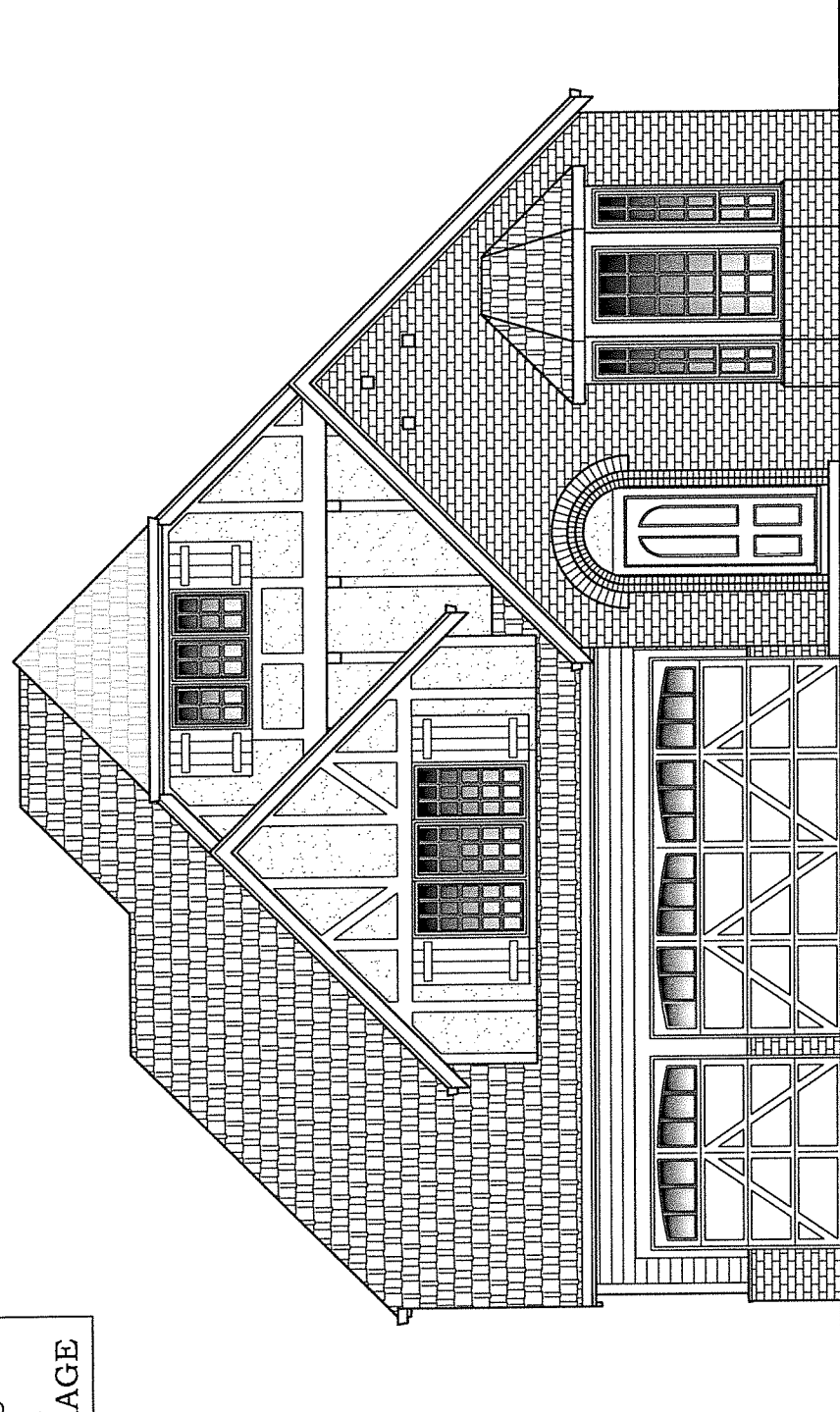

MAIN LEVEL FLOOR PLAN (9' 11" / 12' CLG'S.)

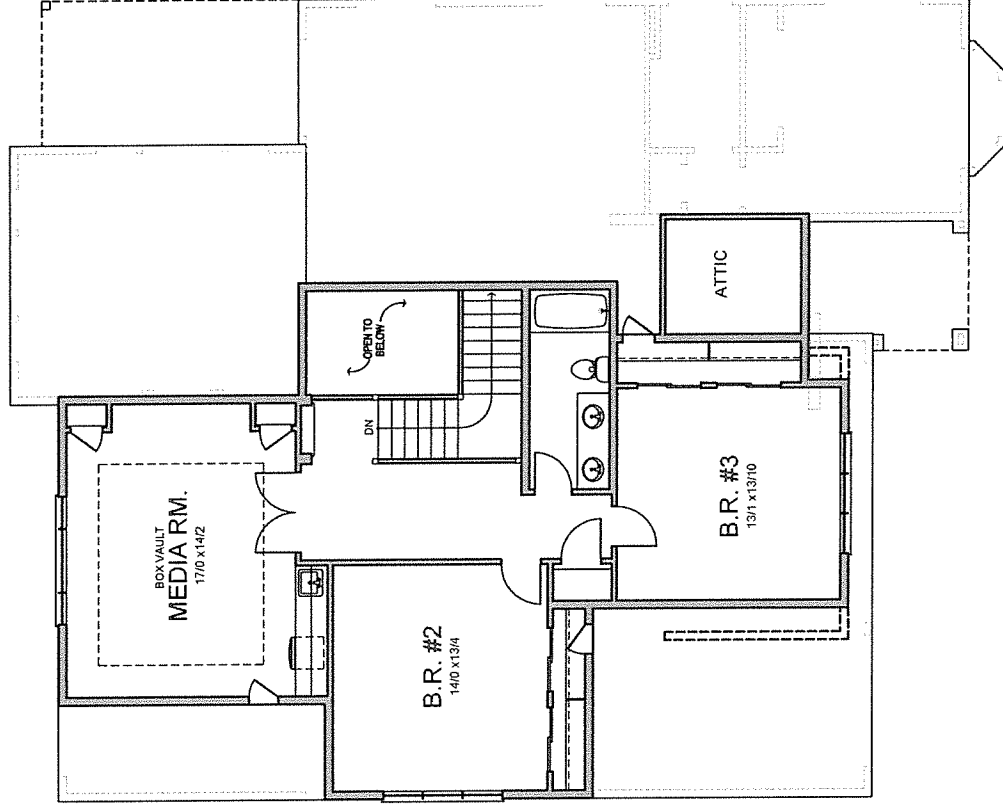

UPPER LEVEL FLOOR PLAN (8' CLG.)



WEST HILLS
HOMES NORTHWEST

3017 BROOKLYN
FRENCH

M. FLR.	=	1,268 S.F.
U. FLR.	=	1,772 S.F.
TOTAL	=	3,040 S.F.
GARAGE	=	466 S.F.



EVERETT

CUSTOM HOMES

4-BEDROOMS
3-BATHS
MEDIA
2-CAR GARAGE

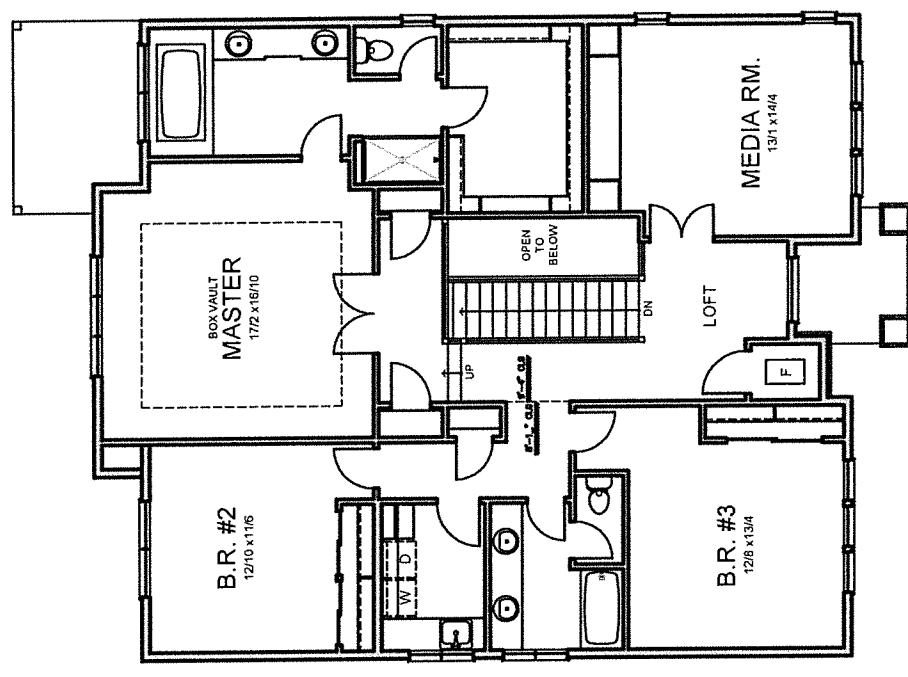
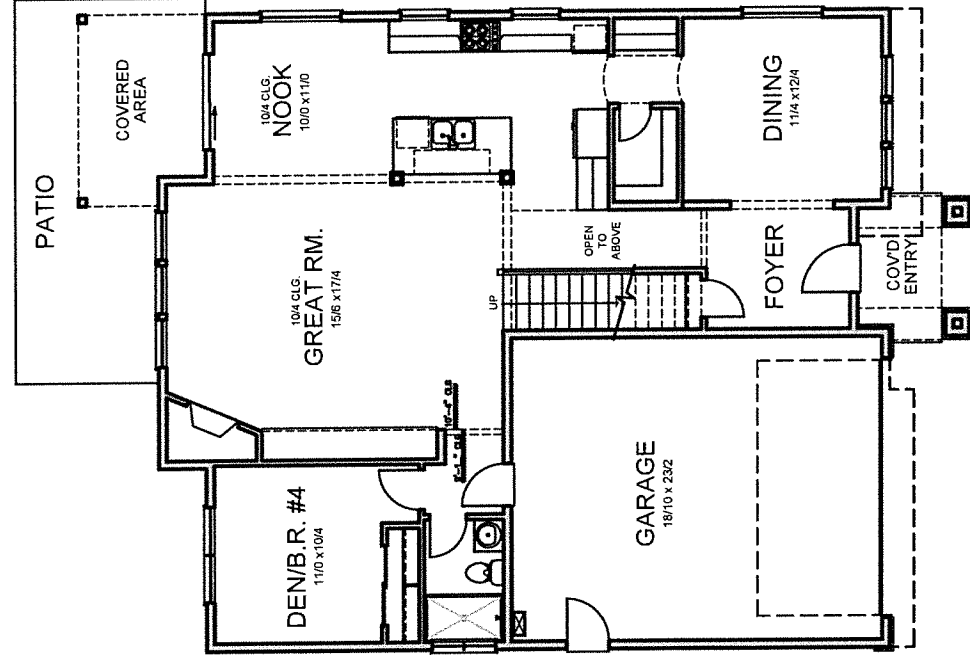
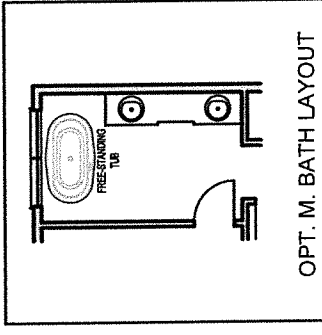
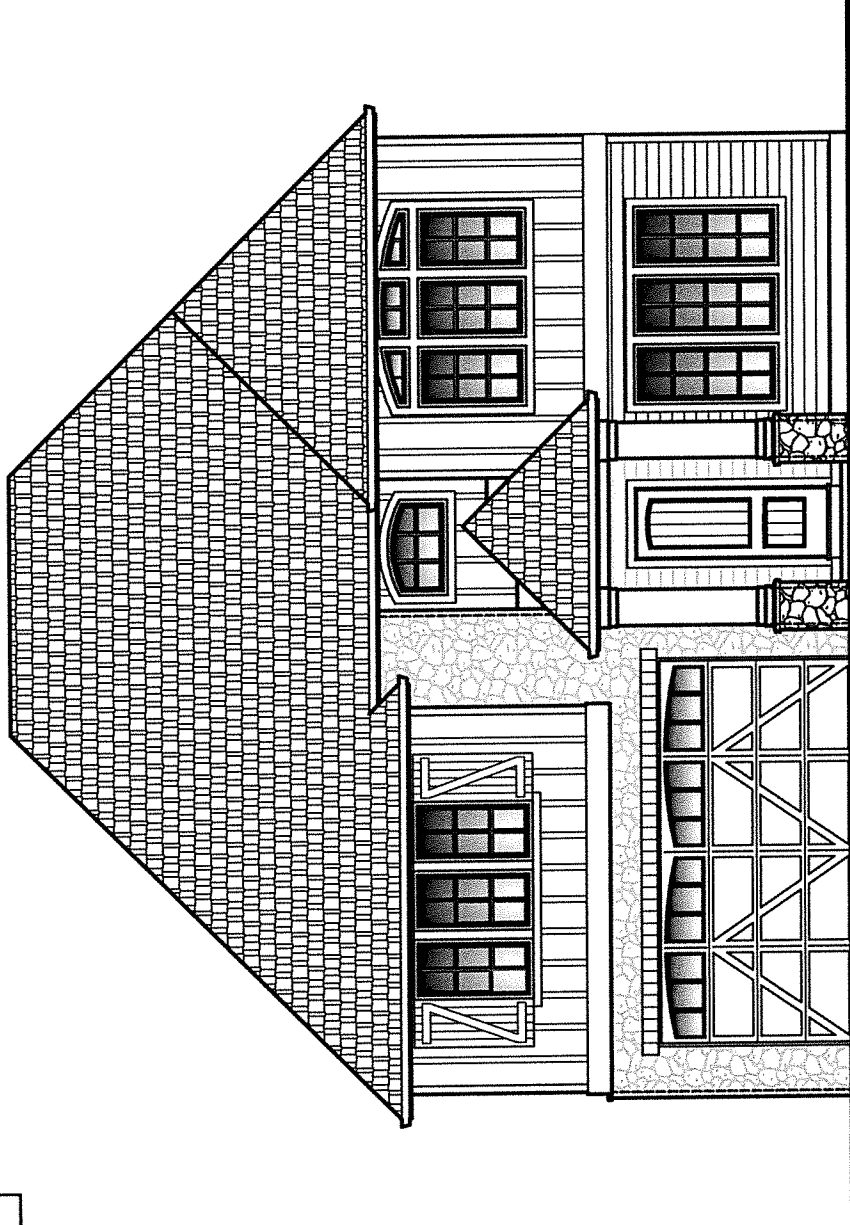



WEST HILLS
HOMES NORTHWEST



EVERETT

CUSTOM HOMES

3330 NW YEON AVE STE 100
PORTLAND, OREGON 97210
PHONE: 503 726-7069

These building plans are produced by United States Building Plans, Inc. ("USBP") and are the property of USBP. All rights reserved. No part of these plans may be reproduced, stored in a retrieval system, or transmitted in any form or by any means, electronic, mechanical, photocopying, recording, or by any information storage and retrieval system, without the prior written permission of USBP. USBP is not responsible for any errors or omissions in these plans. The user assumes all liability for the construction of any building constructed from these plans. The user agrees to hold USBP harmless from and against all claims, damages, and expenses, including reasonable attorneys' fees, arising out of or from the use of these plans. The user also agrees to defend, indemnify, and hold USBP harmless from and against all claims, damages, and expenses, including reasonable attorneys' fees, arising out of or from the use of these plans. The user also agrees to defend, indemnify, and hold USBP harmless from and against all claims, damages, and expenses, including reasonable attorneys' fees, arising out of or from the use of these plans.

7/7/16, PRELIM LAYOUT DOR
4/19/16, PRELIM ENG CHK. DOR
6/7/16, FINISHING ENG. DOR
7/20/16, PG2 IMPLEMENTED DOR
12/9/16, PG2 IMPLEMENTED DOR
1/22/17, PG2 IMPLEMENTED DOR

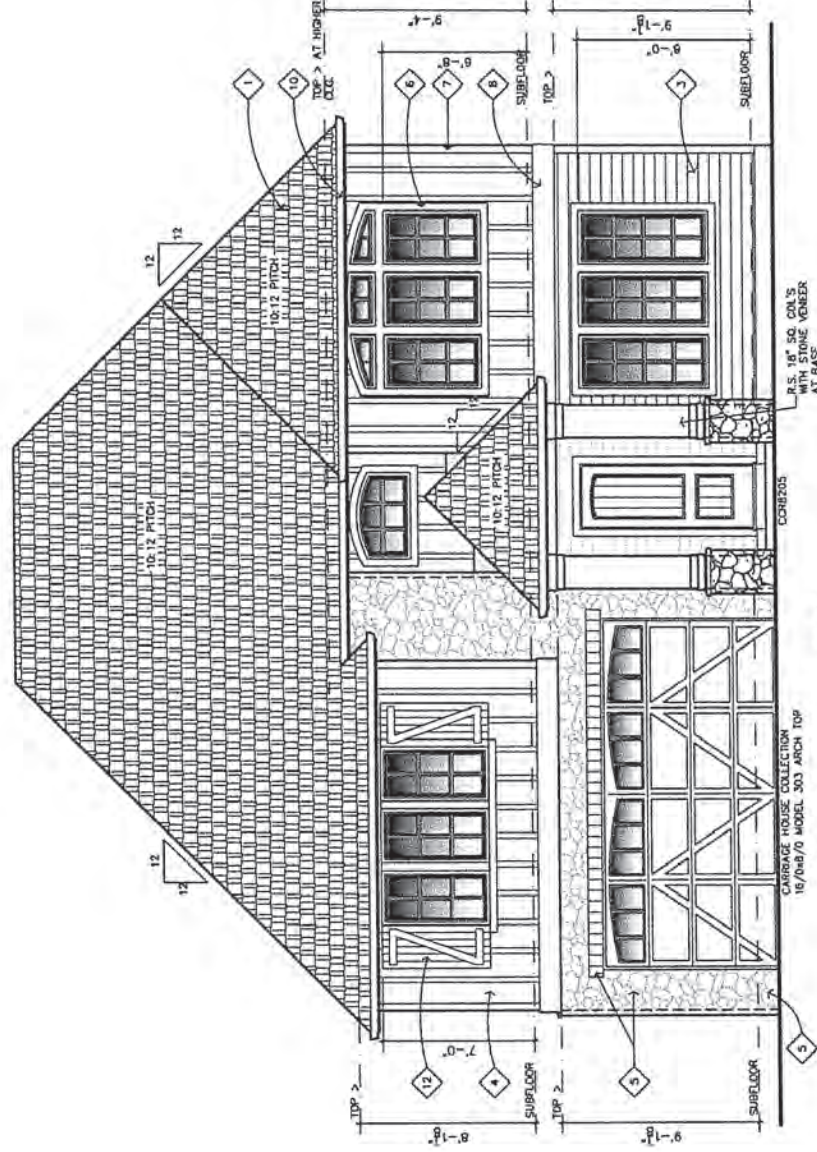

FRONT ELEVATION
1/4" = 1'-0"

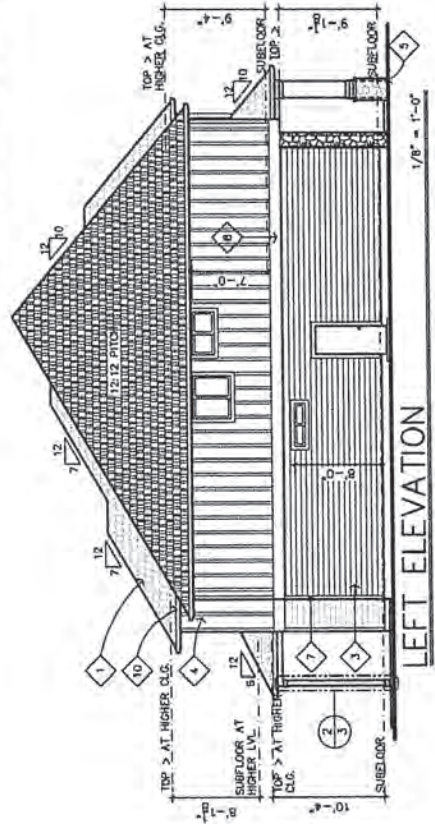

LEFT ELEVATION
1/8" = 1'-0"

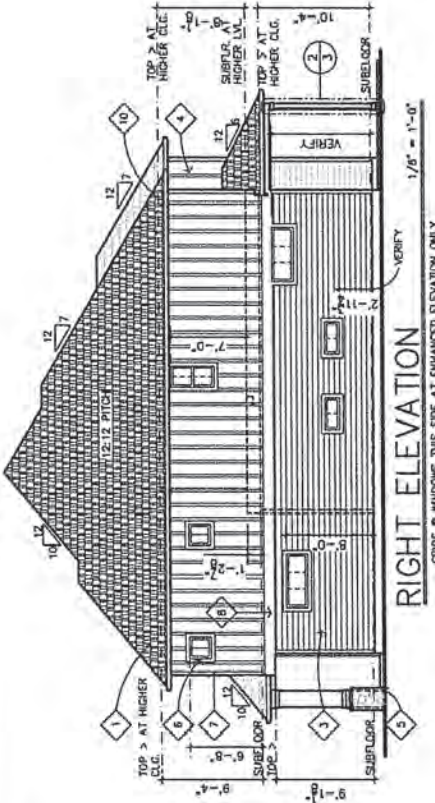

RIGHT ELEVATION
1/8" = 1'-0"

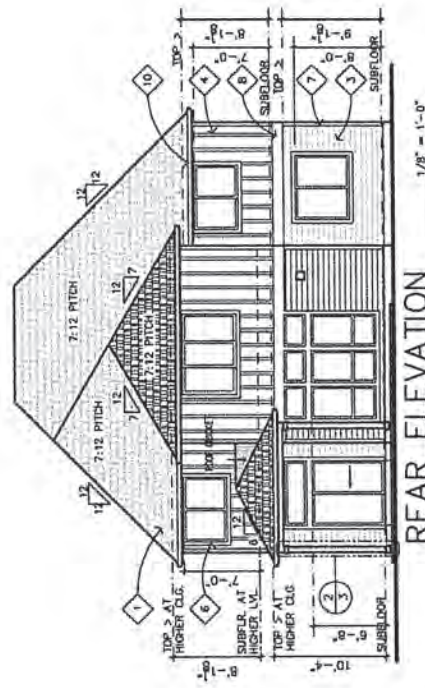

REAR ELEVATION
1/8" = 1'-0"

NOTE:
FOR ALL STRUCTURAL
INFORMATION REFER
TO THE (S) SHEETS

PLAN 3017
BROOKLYN
FRENCH
GARAGE LEFT

MAIN LEVEL: 1,388 SQ FT
UPPER LEVEL: 1,272 SQ FT
GRAND TOTAL: 2,660 SQ FT
GARAGE: 448 SQ FT
SHEET #

Appendix I

Service Provider Letter from Republic Services dated November 4, 2021, and
Proposed Republic Services Plan dated October 27, 2021





November 4, 2021

Keith Buisman

Re: Frog Pond Oaks
Wilsonville, OR 97070

Dear Keith,

Thank you, for sending us the preliminary site plans for this proposed development in Wilsonville.

My Company: Republic Services of Clackamas and Washington Counties has the franchise agreement to service this area with the City of Wilsonville, OR.

We have reviewed your plans for extending development at Frog Pond Oaks. Republic Services approves your trash and recycle service provider plan as outlined in your email 10/28/2021:

- Lots 11 through 15 (Street C) and 26 through 27 (Street D) will have interim waste pickup near the closest intersection as marked up on the attached plan until the future extension for each street has been completed. The interim requirement will be addressed with specific recorded CC&Rs against the lots with compliance and enforcement by the HOA. Future changes to service to be approved by Republic Services.
- Street E will have a dedicated turnaround for fire and waste hauling within the tract.
- The map shows where pickup of these bins would occur.

To ensure cart placement space is available for residence, Republic Services will require parking restriction signage be provided where bins would be placed for these lots. Minimum spacing for each residential trash and recycle cart package must be a minimum 2' x 8' spacing to accommodate each lot's bins.

Thanks Keith, for your help and concerns for our services prior to this project being developed.

Sincerely,

A handwritten signature in blue ink, appearing to read "Kelly Herrod", with a stylized flourish at the end.

Kelly Herrod
Operations Supervisor
Republic Services Inc.

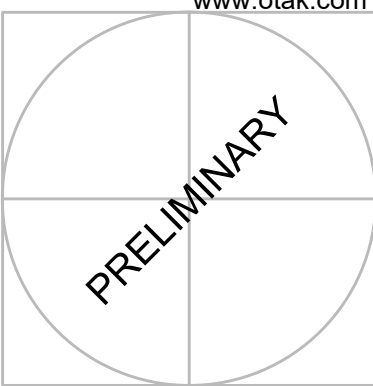

FROG POND OAKS
41 DETACHED SINGLE FAMILY LOTS
CITY OF WILSONVILLE, OREGON

PRELIMINARY STREET CROSS SECTIONS

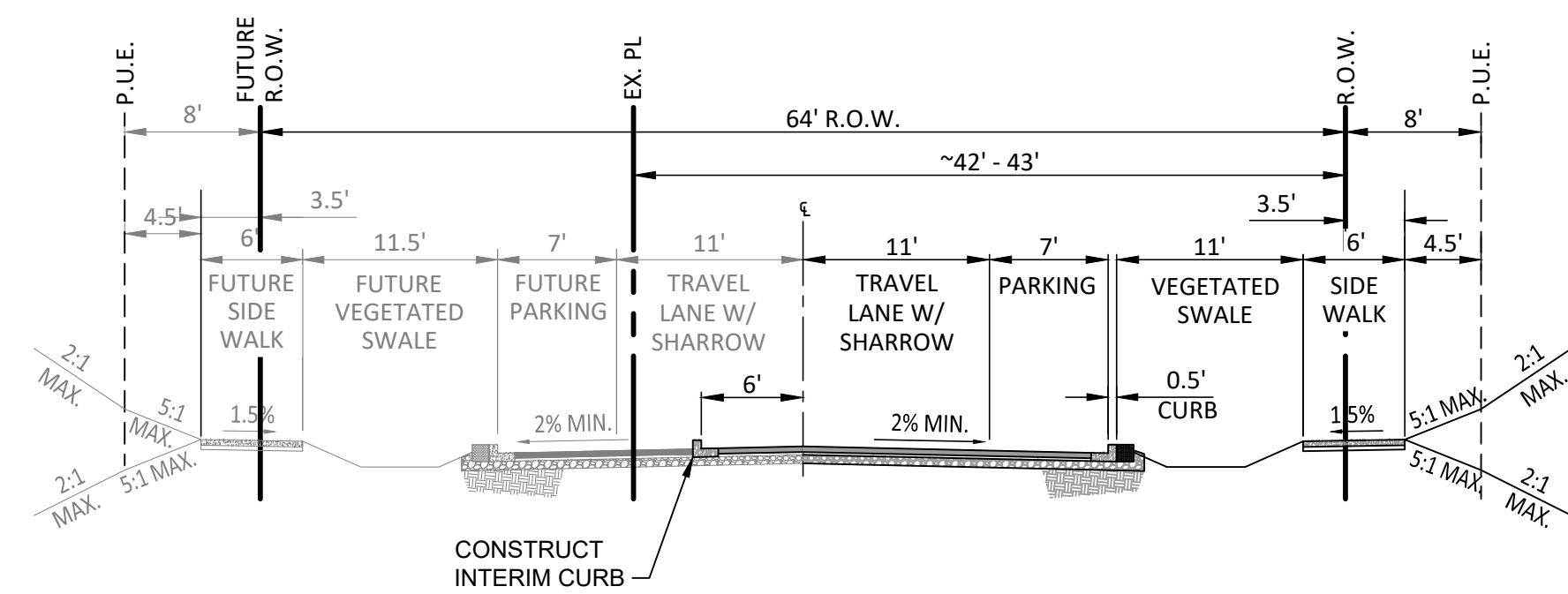

A **WILLOW CREEK DR**
(COLLECTOR - GATEWAY - PARKING ON BOTH SIDES)
SCALE: 1" = 10'-0"

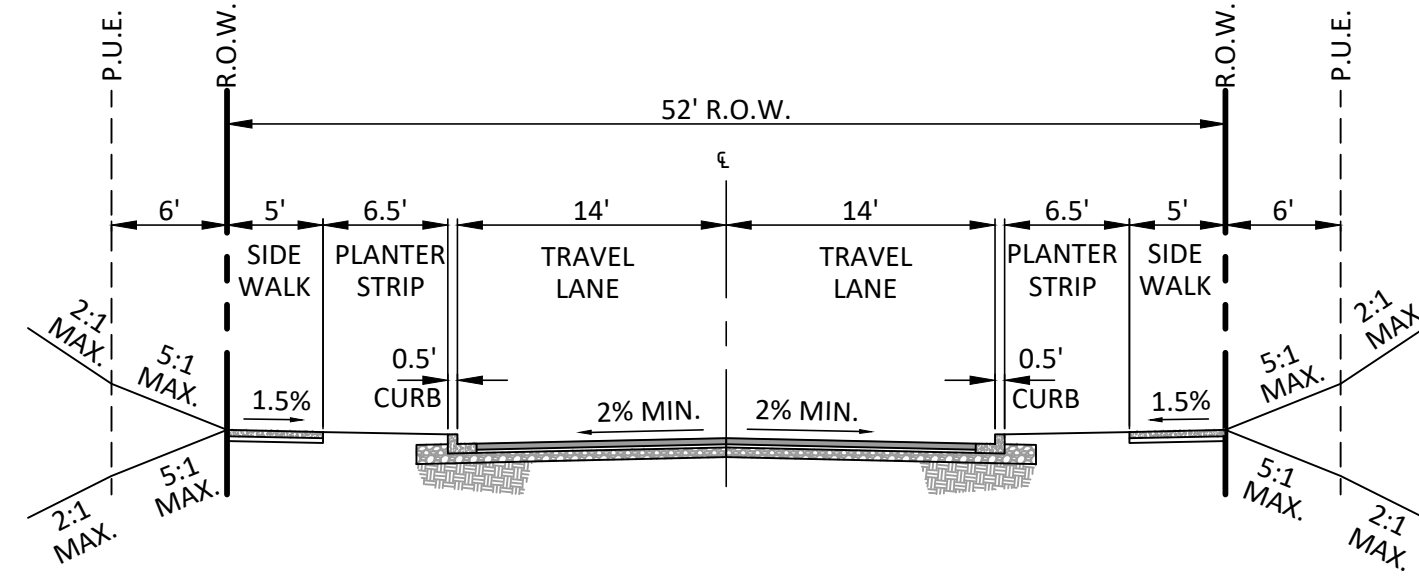

B **STREET C, STREET D, STREET E, LARKSPUR TERRACE**
(LOCAL STREET - PARKING ON BOTH SIDES)
SCALE: 1" = 10'-0"

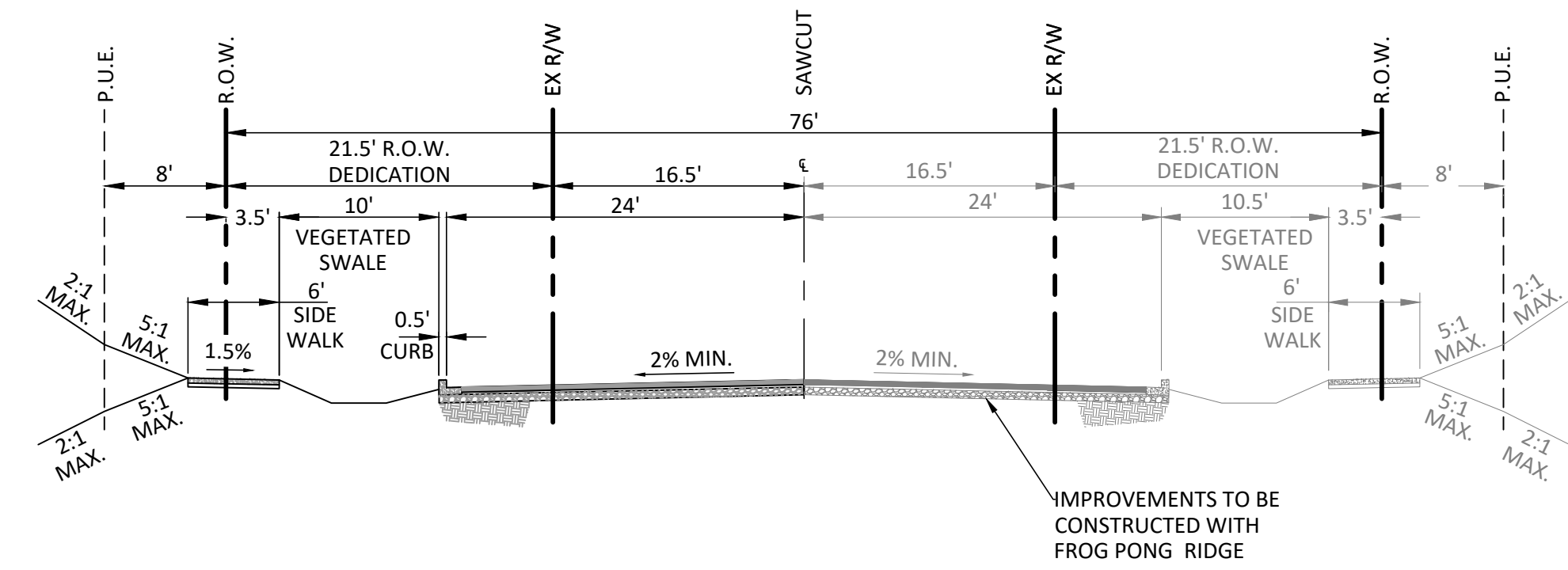

C **SW FROG POND LN**
(COLLECTOR - GATEWAY - NO PARKING)
SCALE: 1" = 10'-0"

STREET CROSS SECTIONS

SEE SHEET P2.00 FOR SECTION LOCATIONS

#	DATE	DESCRIPTION

REVISIONS	
NAV/D88 DATUM	
OTAK CAD DRAWN BY	KJB CHECKED BY
LAND USE SUBMITTAL STATUS	
TBD DATE	
20141 PROJECT NUMBER	

P2.10

Appendix J

Service Provider Letter from Tualatin Valley Fire and Rescue October 25, 2021



**FIRE CODE / LAND USE / BUILDING REVIEW
APPLICATION**



North Operating Center
11945 SW 70th Avenue
Tigard, OR 97223
Phone: 503-649-8577

South Operating Center
8445 SW Elligsen Rd
Wilsonville, OR 97070
Phone: 503-649-8577

REV 6-30-20

Project Information

Applicant Name: West Hills Land Development
Address: 3330 NW Yeon Ave Suite 200 Portland, OR 97210
Phone: (503) 641-7342
Email: dan@westhillsdevelopment.com
Site Address: 6725 SW Frog Pond Ln
City: Wilsonville, OR 97070
Map & Tax Lot #: (3S 1W 12D TL 401 and 402)
Business Name: N/A Frog Pond Oaks
Land Use/Building Jurisdiction: Wilsonville
Land Use/ Building Permit # N/A

Choose from: Beaverton, Tigard, Newberg, Tualatin, North Plains, West Linn, Wilsonville, Sherwood, Rivergrove, Durham, King City, Washington County, Clackamas County, Multnomah County, Yamhill County

Project Description
**41-lot single family detached
subdivision**

Permit/Review Type (check one):

- Land Use / Building Review - Service Provider Permit
- Emergency Radio Responder Coverage Install/Test
- LPG Tank (Greater than 2,000 gallons)
- Flammable or Combustible Liquid Tank Installation (Greater than 1,000 gallons)
 - * Exception: Underground Storage Tanks (UST) are deferred to DEQ for regulation.
- Explosives Blasting (Blasting plan is required)
- Exterior Toxic, Pyrophoric or Corrosive Gas Installation (in excess of 810 cu.ft.)
- Tents or Temporary Membrane Structures (in excess of 10,000 square feet)
- Temporary Haunted House or similar
- OLCC Cannabis Extraction License Review
- Ceremonial Fire or Bonfire (For gathering, ceremony or other assembly)

For Fire Marshal's Office Use Only

TVFR Permit # 2021-0113
Permit Type: SPP-COW
Submittal Date: 10-22-21
Assigned To: DFM Arn
Due Date: _____
Fees Due: Ø
Fees Paid: Ø

Approval/Inspection Conditions
(For Fire Marshal's Office Use Only)

This section is for application approval only

[Signature] 0430 10-25-21
Fire Marshal or Designee Date

Conditions:

See Attached Conditions: Yes No

Site Inspection Required: Yes No

This section used when site inspection is required

Inspection Comments:

Final TVFR Approval Signature & Emp ID Date

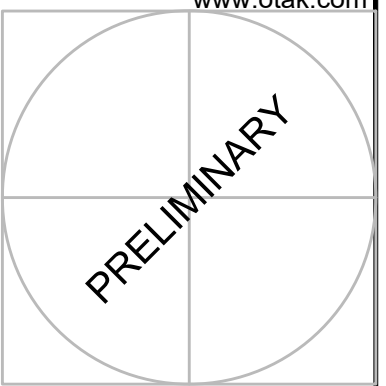

STAMP
WEST HILLS
LAND DEVELOPMENT
CONSULTANT

FROG POND OAKS
41 DETACHED SINGLE FAMILY LOTS
CITY OF WILSONVILLE, OREGON

PRELIMINARY SITE PLAN

TITLE
DATE DESCRIPTION

#	DATE	DESCRIPTION

REVISIONS

NO	DATE	DESCRIPTION

APPROVED PLANS
APPROVAL OF PLANS IS NOT AN APPROVAL OF OMISSIONS OR OVERSIGHTS.
Jessie Ann Gales
Deputy Fire Marshal II
TVF&R Permit # 2021-0113

TBD DATE
20141 PROJECT NUMBER
P2.00
© 2021 OTAK, INC.
If this drawing is not 22" x 34", it has been reduced/enlarged. Scale accordingly.

LEGEND

- PROPERTY LINE
- CENTER LINE
- LOT LINE
- LOT SETBACK
- LOT NUMBER / NAME 16
- EASEMENT LINE
- STANDARD CURB
- SIDEWALK
- RETAINING WALL
- INTERSECTION SIGHT DISTANCE x=DESIGN SPEED(MPH)x10/MPH
- TYPICAL STREET CROSS SECTION (SEE SHEET C2.10)
- PUBLIC RAIN GARDEN
- DRIVEWAY
- CURB RAMP

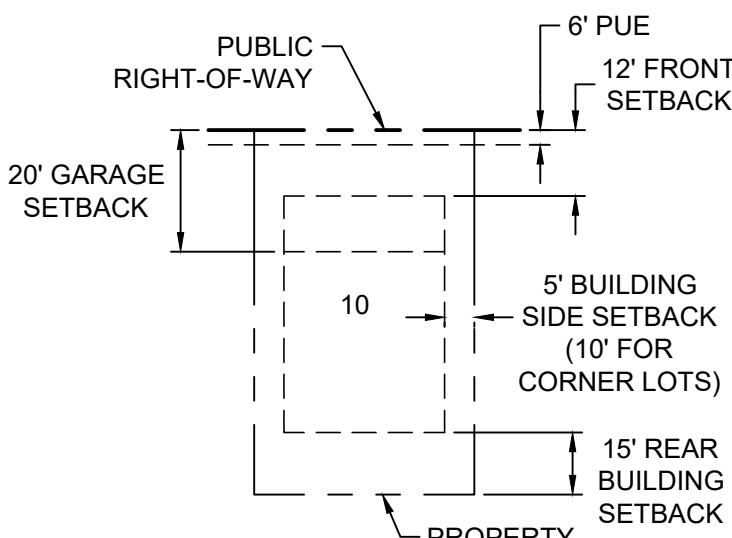

R5 FRONT LOADED SINGLE FAMILY BUILDING SETBACKS LOTS 1-12 NTS

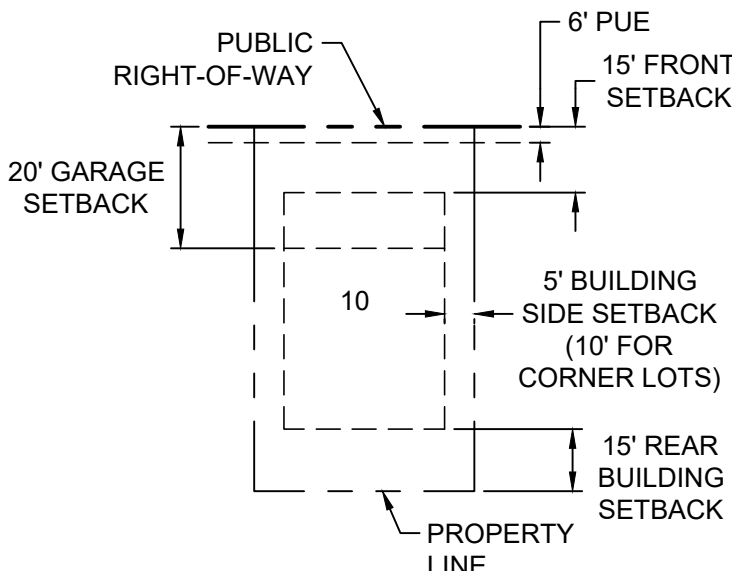

R7 FRONT LOADED SINGLE FAMILY BUILDING SETBACKS LOTS 13-41 NTS



APPROVED PLANS
APPROVAL OF PLANS IS NOT AN APPROVAL OF OMISSIONS OR OVERSIGHTS.
Jessie Ann Gales
Deputy Fire Marshal II
TVF&R Permit # 2021-0113

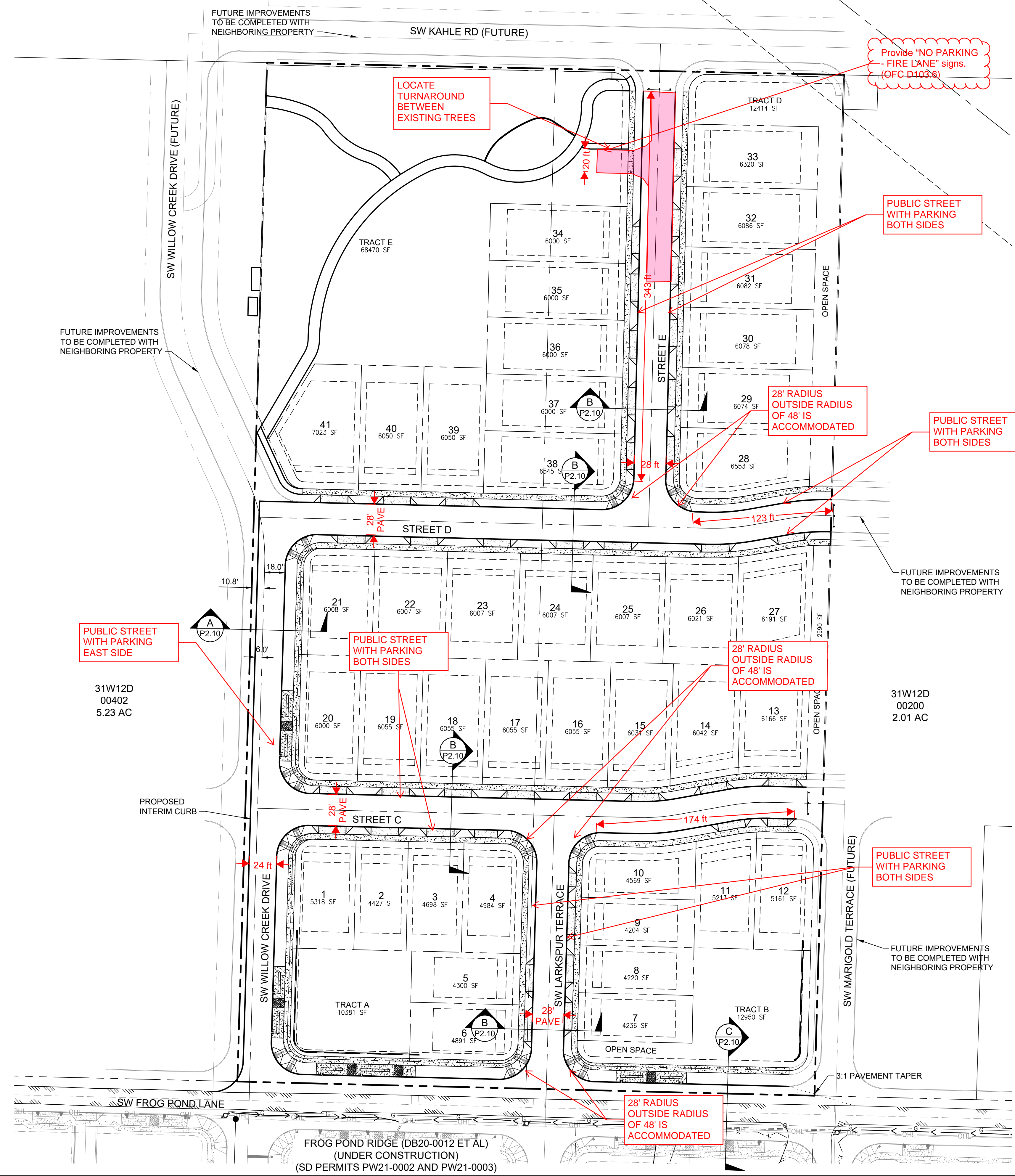
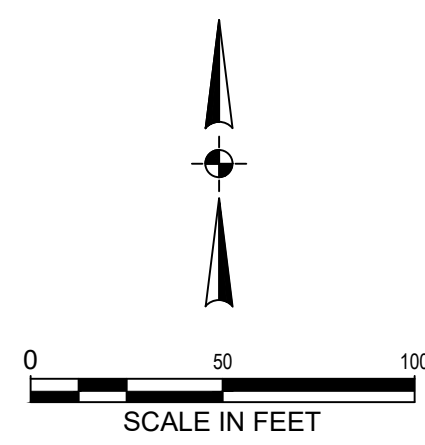

Plotted: Oct 21, 2021 - 12:33pm - Josh Mathison - L:\Projects\2010\2011\1\CAD\ADD\ACAD\Draw\Erra_Pordf - Ocas\P2014\F200.dwg - LayoutName: P2.00

EXHIBIT FP-1

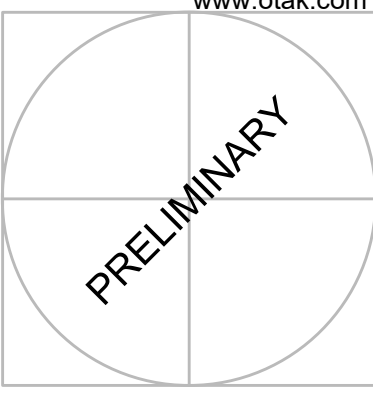

STAMP

WEST HILLS
LAND DEVELOPMENT
CONSULTANT

FROG POND OAKS
41 DETACHED SINGLE FAMILY LOTS
CITY OF WILSONVILLE, OREGON

PRELIMINARY STREET CROSS SECTIONS

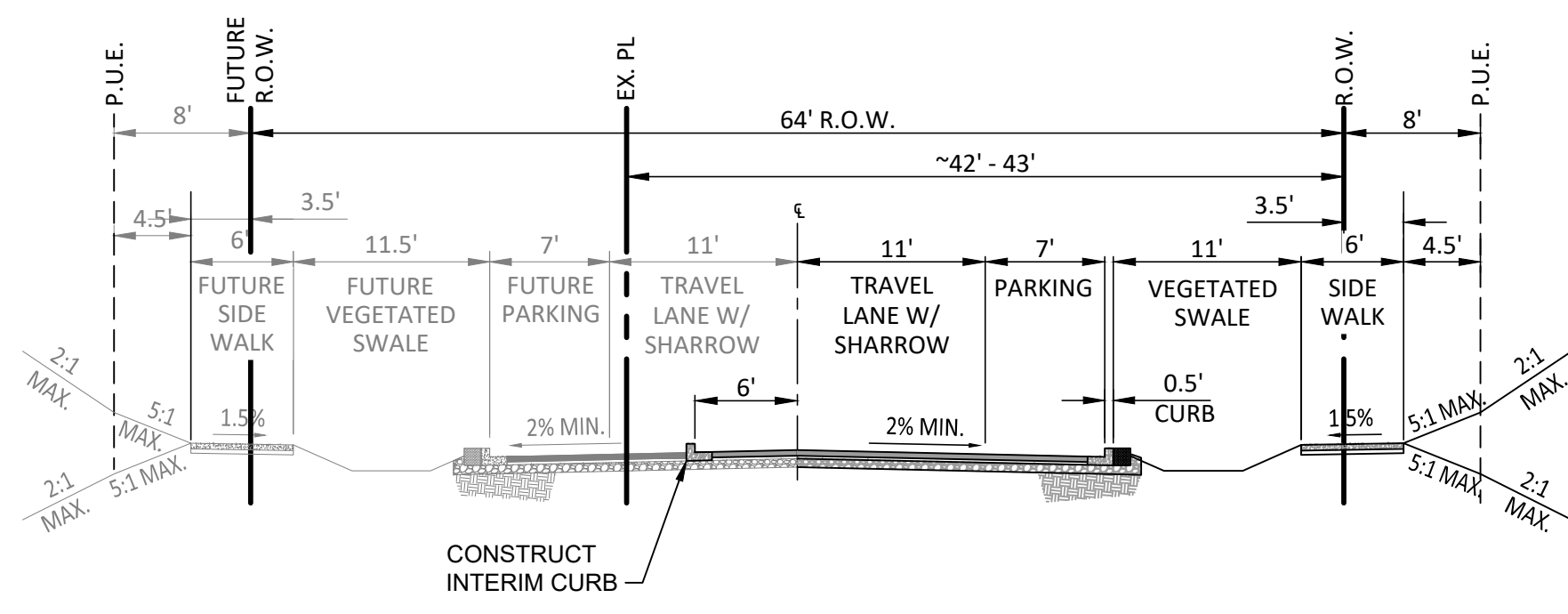

A WILLOW CREEK DR
(COLLECTOR - GATEWAY - PARKING ON BOTH SIDES)
SCALE: 1" = 10'-0"

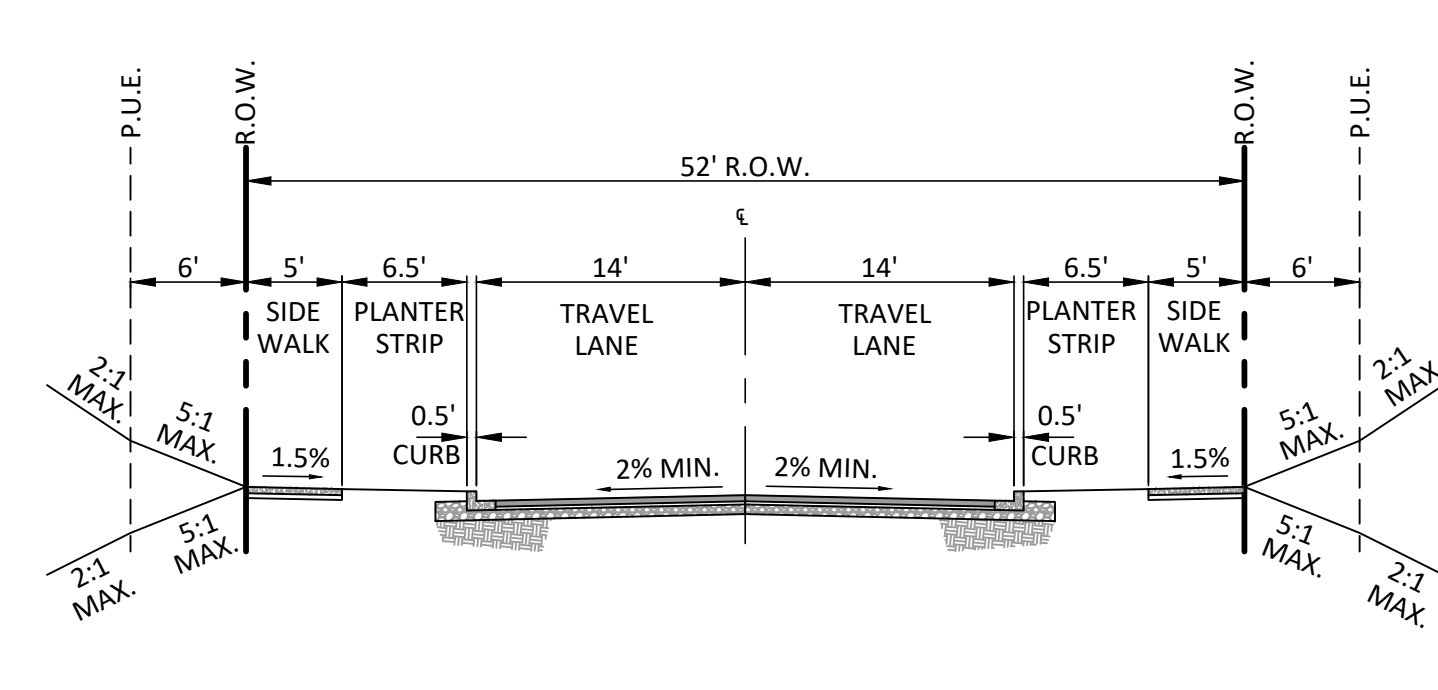

B STREET C, STREET D, STREET E, LARKSPUR TERRACE
(LOCAL STREET - PARKING ON BOTH SIDES)
SCALE: 1" = 10'-0"

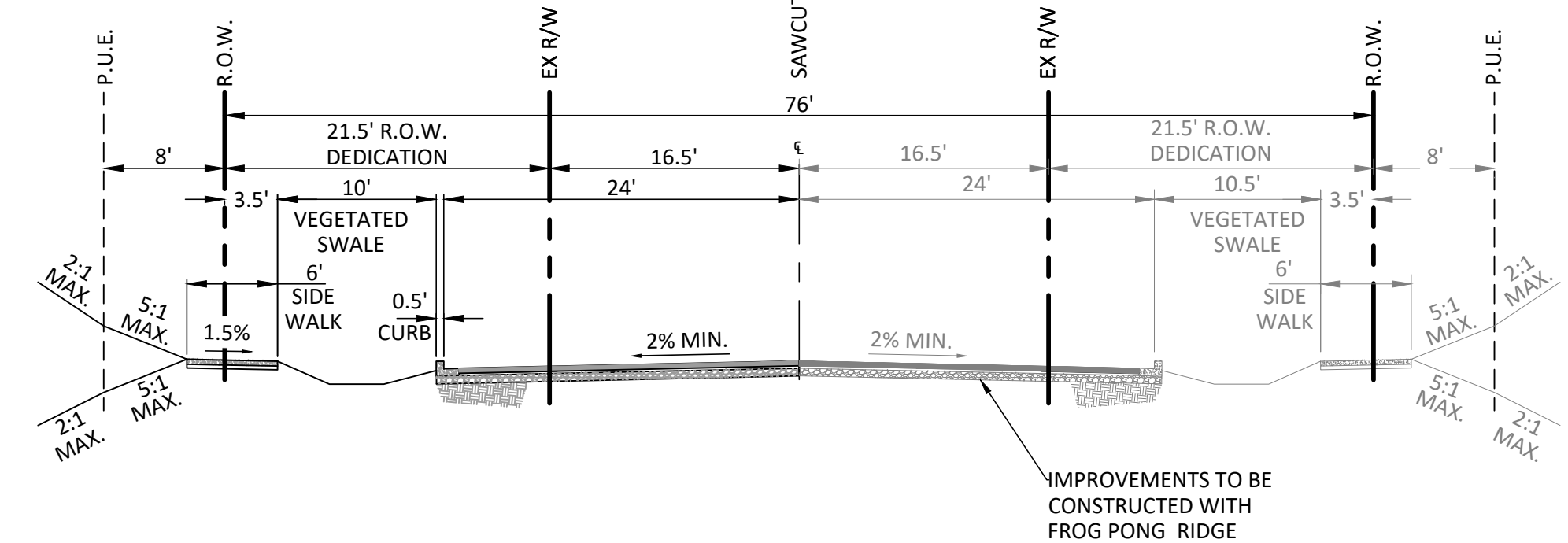

C SW FROG POND LN
(COLLECTOR - GATEWAY - NO PARKING)
SCALE: 1" = 10'-0"

STREET CROSS SECTIONS
SEE SHEET P2.00 FOR SECTION LOCATIONS

APPROVED PLANS
APPROVAL OF PLANS IS NOT AN APPROVAL
OF OMISSIONS OR OVERSIGHTS.
Jason G. Gault
Deputy Fire Marshal II
TVF&R Permit # 2021-0113

#	DATE	DESCRIPTION

REVISIONS

NAV/D88
DATUM

OTAK CAD KJB
DRAWN BY CHECKED BY

LAND USE SUBMITTAL
STATUS

TBD
DATE

20141
PROJECT NUMBER

P2.10
© 2021 OTAK, INC.
If this drawing is not 22" x 34", it has been reduced/enlarged. Scale accordingly.

EXHIBIT FP-2

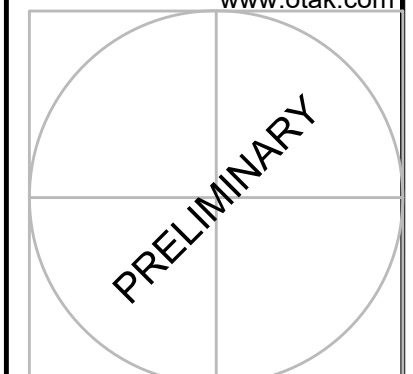

UTILITY KEY NOTES

- ① CONNECT TO EXISTING SANITARY SEWER.
- ② CONNECT TO EXISTING STORM SEWER.
- ③ CONNECT TO EXISTING WATER LINE.
- ④ PROPOSED RAIN GARDEN (CITY STD. DWG. ST-6020)
- ⑤ PROPOSED VEGETATED SWALE (CITY STD. DWG. ST-6045 W/ 12" WIDE CONCRETE STEP-OFF WALK ADJACENT TO PAVEMENT.)
- ⑥ STORM SEWER OUTFALL TO RAIN GARDEN.
- ⑦ PROPOSED WATER QUALITY MANHOLE.
- ⑧ EXISTING FIRE HYDRANT.

LEGEND

SITE	PROPOSED
PROJECT BOUNDARY	-----
STORM DRAIN MANHOLE	⊙
STORM DRAIN CLEAN OUT	⊙
LIDA FLOW CONTROL STRUCTURE (BEEHIVE: CITY STANDARD DWG. ST-6120)	•
CATCH BASIN	■
STORM DRAIN MAIN	—SD—
STORM DRAIN LATERAL	—SD—
SANITARY SEWER MANHOLE	⊙
SANITARY SEWER CLEAN OUT	⊙
SANITARY SEWER MAIN	—SS—
SANITARY SEWER LATERAL	—SS—
WATER VALVE	⊕
WATER BLOW-OFF	⊕
WATER METER	⊕
WATER FIRE HYDRANT	⊕
WATER MAIN	—W—
WATER LATERAL	—W—
PUBLIC LIDA W/CURB OPENINGS (CITY STD. DWG. ST-6012)	⊕
STREET LIGHT PGE OPTION "B" LED WITH WESTBROOKE 35W LED AND 18" DECORATIVE ALUMINUM POLE (20' MOUNTING HEIGHT W/ 4' MAST ARM)	⊕

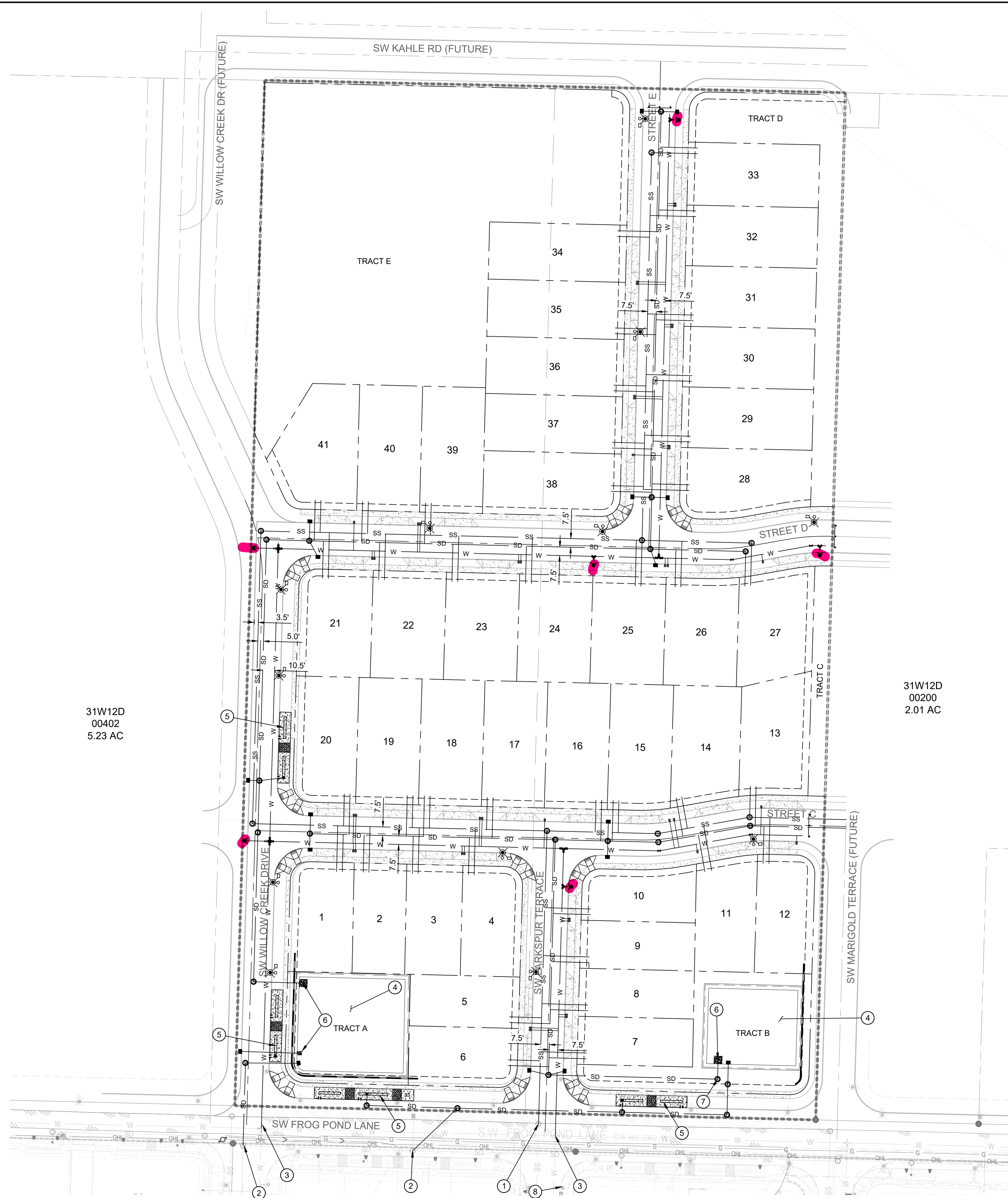

31W12D
00402
5.23 AC

31W12D
00200
2.01 AC

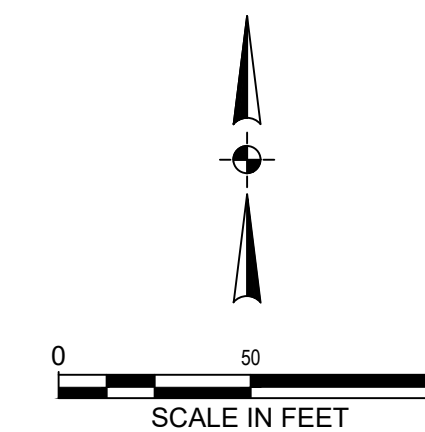

FROG POND OAKS
41 DETACHED SINGLE FAMILY LOTS
CITY OF WILSONVILLE, OREGON

PRELIMINARY UTILITY PLAN

#	DATE	DESCRIPTION

REVISIONS	
NAVD88 DATUM	
OTAK CAD	KJB
DRAWN BY	CHECKED BY
LAND USE SUBMITTAL STATUS	
TBD DATE	
20141 PROJECT NUMBER	
P4.00	
© 2021 OTAK, INC.	



APPROVED PLANS

APPROVAL OF PLANS IS NOT AN APPROVAL OF OMISSIONS OR OVERSIGHTS.

Jason Am...
Deputy Fire Marshal II

TVFR Permit # 2021-0113

EXHIBIT FP-3

Appendix K
Email Correspondence with Bonneville Power Administration (BPA)
regarding Potential Easement and BPA Land Use Application



Steven McAtee

From: Steven McAtee
Sent: Sunday, February 13, 2022 9:11 AM
To: Steven McAtee
Subject: FW: Frog Pond Oaks - BPA Easement

From: Smith,Darin L (BPA) - TERR-CHEMAWA <dxsmith@bpa.gov>
Sent: Friday, December 17, 2021 6:30 AM
To: Keith Buisman <keith.buisman@otak.com>
Cc: Schneider,Jerry (CONTR) - TERR-CHEMAWA <jschneider@bpa.gov>; Li Alligood <Li.Alligood@otak.com>; 20141 <20141@otak.com>
Subject: RE: Frog Pond Oaks - BPA Easement

No the easement can be seeded without an LUA

From: Keith Buisman <keith.buisman@otak.com>
Sent: Thursday, December 16, 2021 5:10 PM
To: Smith,Darin L (BPA) - TERR-CHEMAWA <dxsmith@bpa.gov>
Cc: Schneider,Jerry (CONTR) - TERR-CHEMAWA <jschneider@bpa.gov>; Li Alligood <Li.Alligood@otak.com>; 20141 <20141@otak.com>
Subject: [EXTERNAL] RE: Frog Pond Oaks - BPA Easement

Hi Darin,

We're not proposing any physical changes to the area within the easement aside from some grass seed to ensure adequate ground cover. (The tract is just for preserving existing trees – no new above ground planting is proposed.)

I don't have specifics on the roadway aside from the dedication as we are not designing the roadway.

I think the application would best be completed when there are a few more details to provide with an actual street design.

Based on this, do you still think we need to complete a LUA?

Thanks,

Keith

Keith Buisman, PE | Civil Engineer
Otak, Inc.

Direct: 503.415.2337 | Main: 503.287.6825

From: Smith,Darin L (BPA) - TERR-CHEMAWA <dxsmith@bpa.gov>
Sent: Thursday, December 16, 2021 8:57 AM
To: Keith Buisman <keith.buisman@otak.com>

Cc: Schneider, Jerry (CONTR) - TERR-CHEMAWA <jschneider@bpa.gov>

Subject: RE: Frog Pond Oaks - BPA Easement

Attached is the application for a land use agreement. It needs to be completed for anything within our Easement you add or change, as we need to look at it also for safety and to document what is happening. If it's just greenspace being left alone we do not need application.

If you have a future road that you have the specs and info on, even if it's not part of this phase it's not a bad idea to get it included in a LUA to get it in the process of getting approved not so you have our specs for building and safety concerns. Do not plan any fire hydrants or water valves within or ROW and light poles/Signs will be height limited and trees prohibited just an FYI

From: Keith Buisman <keith.buisman@otak.com>

Sent: Wednesday, December 15, 2021 2:45 PM

To: Smith, Darin L (BPA) - TERR-CHEMAWA <dxsmith@bpa.gov>

Cc: Mandy Flett <mandy.flett@otak.com>; 20141 <20141@otak.com>; Clark, James L (BPA) - TERR-3 <jlclark@bpa.gov>

Subject: [EXTERNAL] RE: Frog Pond Oaks - BPA Easement

Hi Darin,

Please see attached site plan for reference. Can you let me know what you need in order to provide written permission for creation of right-of-way within the BPA easement?

Thanks,

Keith

Keith Buisman, PE | Civil Engineer
Otak, Inc.

Direct: 503.415.2337 | Main: 503.287.6825

From: Clark, James L (BPA) - TERR-3 <jlclark@bpa.gov>

Sent: Monday, December 13, 2021 11:17 AM

To: Keith Buisman <keith.buisman@otak.com>

Cc: Mandy Flett <mandy.flett@otak.com>; 20141 <20141@otak.com>; Smith, Darin L (BPA) - TERR-CHEMAWA <dxsmith@bpa.gov>

Subject: RE: Frog Pond Oaks - BPA Easement

Hi Keith,

Darin Smith is the best BPA contact for assisting you with this proposal.
I Cc'd Darin on this email.

Thank you,

Jim Clark

Regional Realty Officer-Northwest

BONNEVILLE POWER ADMINISTRATION

jlclark@bpa.gov | P 503-230-5341 | C 503-758-3883



From: Keith Buisman <keith.buisman@otak.com>
Sent: Monday, December 13, 2021 8:53 AM
To: Clark, James L (BPA) - TERR-3 <jlclark@bpa.gov>
Cc: Mandy Flett <mandy.flett@otak.com>; 20141 <20141@otak.com>
Subject: [EXTERNAL] Frog Pond Oaks - BPA Easement

Hi Jim,

I'm working on a single family residential development project in Wilsonville, Oregon and there is a portion of an existing BPA easement that clips the northeast corner of the property. The City has requested we obtain documentation from BPA that confirms the proposed right-of-way dedication in the easement is acceptable. Mandy Flett noted that she's worked with you in the past and that you'd probably be able to help us with this request or point us in the right direction.

Below is a vicinity map of the site location within Wilsonville. (Interstate 5 is just to the west of the screenshot.)

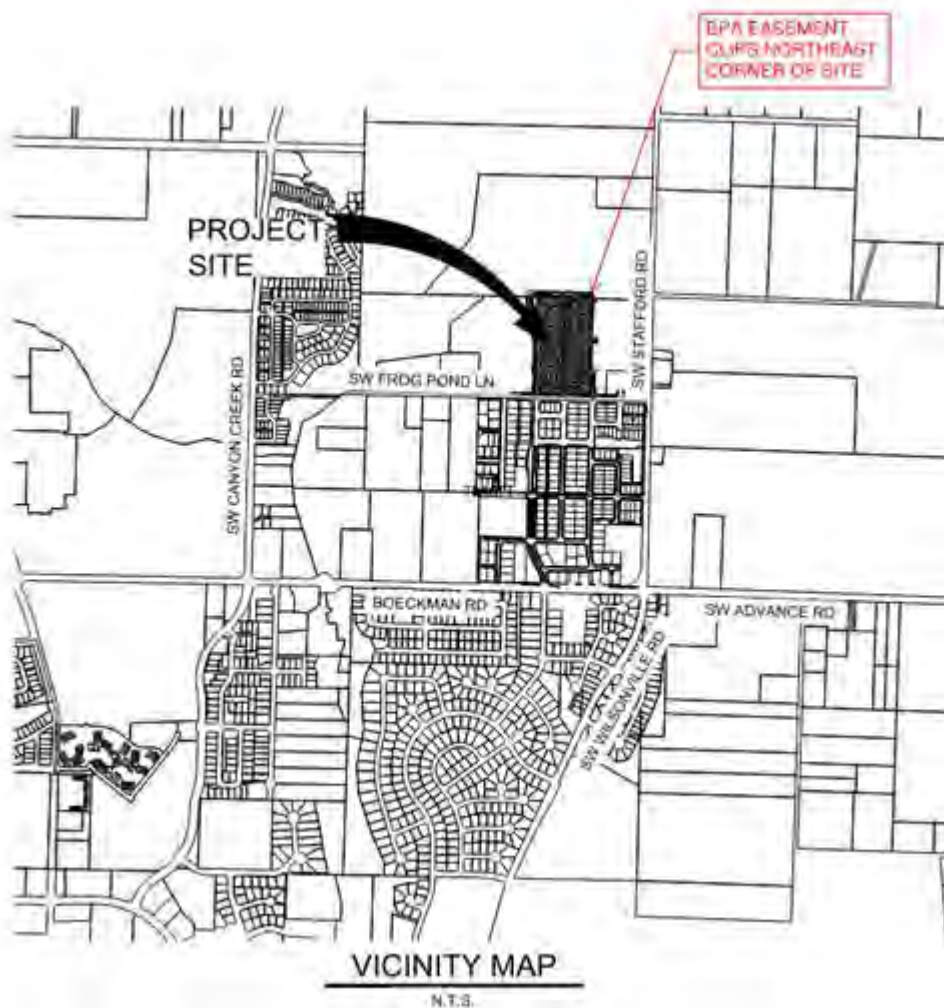

See attached site plan with markup of the area within the BPA easement. The following uses are proposed:

- Right-of-way dedication only. Future developments north will construct street improvements including curb, sidewalk, paving, street trees, and street lighting.

- Open space tract. No structures are proposed within the tract. The tract is created to preserve existing trees along the north and east side of the development. There will be no future development of this tract in the future.

Can you let me know what else you would need in order to provide correspondence that allows for right-of-way dedication and tract creation within this easement? I appreciate any assistance you can provide in addressing the City's request.

Thanks,

Keith



Keith Buisman, PE | Civil Engineer

808 SW Third Ave., Suite 800 | Portland, OR 97204

Direct: 503.415.2337 | Office: 503.287.6825

www.otak.com